



# AIMS K-12 College Prep Charter District

## Special Finance Committee Meeting

---

### Date and Time

Thursday September 10, 2020 at 6:00 PM PDT

### Location

Zoom - <https://zoom.us/j/99007073783>

---

AIMS does not discriminate on the basis of disability in the admission or access to, or treatment or employment in, its programs or activities. Marisol Magana has been designated to receive requests for disability-related modifications or accommodations in order to enable individuals with disabilities to participate in open and public meetings at AIMS. Please notify Marisol Magana at (510) 220-9985 at least 24 hours in advance of any disability accommodations being needed in order to participate in the meeting. **All comments and questions should be entered into the chat feature of the Zoom meeting.**

Join Zoom Meeting <https://us02web.zoom.us/j/87086078199?pwd=UytpNENKazRlOSStLRWR0bTVGZ1JaZz09>  
Meeting ID: 870 8607 8199 Password: 3wrGPs

---

### Agenda

#### I. Opening Items

Opening Items

A. Call the Meeting to Order

**B. Record Attendance and Guests**

**C. Public Comment on Non-Action Items**

Public Comment on Non-Action Items is set aside for members of the Public to address the items on the Committee's agenda prior to each agenda item. The Committee will not respond or take action in response to Public Comment, except that the Committee may ask clarifying questions or direct staff. **Comments are limited to two (2) minutes per person, and a total time allotted for all public comment will not exceed twenty (20) minutes (10 minutes per section).**

**D. Public Comment on Action Items**

Public Comment on Action Items is set aside for members of the Public to address the items on the Committee's agenda prior to each agenda item. The Committee will not respond or take action in response to Public Comment, except that the Committee may ask clarifying questions or direct staff. **Comments are limited to two (2) minutes per person, and a total time allotted for all public comment will not exceed twenty (20) minutes (10 minutes per section).**

**II. Non-Action Items**

-Committee Scheduling Discussion

**III. Action Items**

- A.** Unaudited Actuals
- B.** Cyber Security Insurance Renewal
- C.** General Liability Insurance Renewal
- D.** Pre-Approved Vendor List
- E.** Window Installation for 12th Street
- F.** Learning Continuity and Attendance Plan (LCAP) for AIPCS, AIPCS II and AIPHS
- G.** Ring Central Contract

**IV. Closed Session**

- A.** Public Comment on Closed Session Items

Public Comment on Closed Session Items is set aside for members of the Public to address the items in this section prior to closed session. The Committee will not respond or take action in response to Public Comment, except that the Committee may ask clarifying questions or direct staff. **Comments are limited to two (2) minutes per person, and a total time allotted for all public comment will not exceed twenty (20) minutes (10 minutes per section).**

**B. Recess to Closed Session**

Closed Session Items:

1. Conference with Real Property Negotiators  
(Gov. Code Section 54956.9)
2. Conference with Legal Counsel - Anticipated Litigation  
(Gov. Code Section 54956.9)
3. Employee Matters

**C. Reconvene from Closed Session**

Roll Call

**D. Report from Closed Session**

**V. Closing Items**

**A. Items For Next Agenda**

- 
- 
- 
- 

**B. Adjourn Meeting**

**C. NOTICES**

**The next regular meeting of the Board of Directors is scheduled to be held on September 29, 2020, @ 6:30 pm. AIMS does not discriminate on the basis of disability in the admission or access to, or treatment or employment in, its programs or activities. Marisol Magana has been designated to receive requests for disability-related modifications or accommodations in order to enable individuals with disabilities to participate in open and public meetings at**

**AIMS. Please notify Marisol Magana at (510)220-9985 at least 24 hours in advance of any disability accommodations being needed in order to participate in the meeting.**

**I, Kellie Minor, hereby certify that I posted this agenda on the AIMS website @ aimsk12.org, on, September 26, 2020, at 5:55 PM.**

**Certification of Posting**



# Coversheet

## Unaudited Actuals

**Section:** III. Action Items  
**Item:** A. Unaudited Actuals  
**Purpose:** Vote  
**Submitted by:**  
**Related Material:** 01612590111856 (1)Signed.xlsm  
American Indian Model Schools Exec Memo Unaudited (1) Final.docx  
01612590114363 (1) signed.xlsm  
AIMS Finance Comittee Cover 2019-2020 Unaudited Actuals.pdf  
01612596113807 (1) signed.xlsm

## Notice

The following file is attached to this PDF. You will need to open this packet in an application that supports attachments to pdf files, e.g. [Adobe Reader](#):

01612590111856 (1)Signed.xlsm



**American Indian Model Schools**  
*A School at Work!*

**AIPCS I & II**  
 Downtown Oakland Campus

**AIPHS**  
 Lakeview Campus

171 12th Street  
 Oakland, CA 94607

746 Grand Avenue  
 Oakland, CA 94610

Phone: 510.893.8701  
 Fax: 510.893.0345  
 Website: aimschools.org

Phone: 510.893.8701  
 Fax: 510.893.0345  
 Website: aimschools.org

**American Indian Model Schools**  
 2019-2020 Unaudited Actuals Executive Summary

---

American Indian Model Schools is a Charter District comprised of 3 schools. American Indian Public Charter School was initially established in 1996. The American Indian Model Schools Charter District was formed in 2006 with the expansion of schools, adding American Indian Public High School and American Indian Public Charter II (K-8). The Charter is located in Oakland of Alameda County.

American Indian Model Schools currently enroll 1,332 students in 3 schools; One K-8, One Middle School (6-8), and One High School. AIMS currently employs 114 full and 4 part-time staff to serve our students.

**Governance**

The Charters are governed by a volunteer Board of Trustees. There are five members of the Board, each volunteering their term. The school board meets once a month on the third Tuesday of each month. The Board of Trustees is advised by several other committees such as the Governance, Finance, Facility, and LCAP Advisory Committees' that also meet monthly. Charter operations are led by Superintendent Maya Woods-Cadiz.

**Enrollment**

In accordance with the 2016-2021 Charter Agreement with Oakland Unified School District, AIMS has nearly reached its full enrollment capacity. American Indian Public Charter (AIPCS) is capped at 250 students, American Indian Public Charter II (AIPCS II) 675, and American Indian Public High School (AIPHS) at 450. Over the last five years, the District has grown by about 400 students (6/2014 to 6/2019). An enrollment revision to the Charter will be requested during the next authorization phase beginning in 2021.

<u>AIPCS I</u>	<u>AIPCS II</u>	<u>AIPHS</u>	<u>Total</u>
235	665	432	<b>1332</b>
96%	96%	95%	
226.01	638.4	410.4	<b>1274.80</b>

**AIPHS Mission Statement**

AIPHS exists to prepare all students, especially those who have been traditionally underserved, to enter a four-year college after graduation from high school and complete at minimum a four-year degree.



**American Indian  
Model Schools**  
*A School at Work!*

**AIPCS I & II**  
*Downtown Oakland Campus*

**AIPHS**  
*Lakeview Campus*

171 12th Street  
Oakland, CA 94607

746 Grand Avenue  
Oakland, CA 94610

Phone: 510.893.8701  
Fax: 510.893.0345  
Website: aimschools.org

Phone: 510.893.8701  
Fax: 510.893.0345  
Website: aimschools.org

## Budget

American Indian Model Schools' fiscal year is from July 1 to June 30, as prescribed for all governmental agencies in the state. The budget for July 1, 2019, to June 30, 2020, totals \$17,779,983 in expenditures. The General Fund is used to record the day-to-day operations of the Charter. There are seven special-purpose funds to capture the remaining budget.

- GENERAL PURPOSE (LCFF)  
*Special Funds*
- TITLE I
- TITLE II
- TITLE III
- TITLE IV
- ASES: Afterschool Program
- NSLP: Nutrition Program
- LOCAL FUNDS (Measure G1, Donations & Grants)

## Federal

American Indian Model Schools receives federal funding for at-risk students:

- Title I, Part A Low Income at Risk
- Professional Development (Title II)
- English Learners (Title III)
- Funding to provide meals to those students qualifying for free or reduced lunches.

These funds provide necessary services to students attending AIMS schools.

## Budget Benchmarks – Process timeline

- AIMS 2020-2021 Budget Adoption: June 25, 2020
- State's 2020-2021 June Budget Adoption: June 30, 2019
- 45 Day Budget Revision (not required): Mid-August
- **Unaudited Actuals (2019-20 Closing): September 01, 2020**
- First Interim (Realignment based on July – October 31 Activity): December 1, 2020
- January Governors Release (Projections for 2020-2021): January 2021
- Second Interim (Realignment based on Nov 1, 2019– Jan 31, 2020)- March 1, 2021
- Governors May Revise (Revision to Jan. Gov. Release): May 2021
- 2021-22 Budget Adoption – June 15, 2021



**American Indian  
Model Schools**  
*A School at Work!*

**AIPCS I & II**  
*Downtown Oakland Campus*

**AIPHS**  
*Lakeview Campus*

171 12th Street  
Oakland, CA 94607

746 Grand Avenue  
Oakland, CA 94610

Phone: 510.893.8701  
Fax: 510.893.0345  
Website: aimschools.org

Phone: 510.893.8701  
Fax: 510.893.0345  
Website: aimschools.org

**Unaudited Actuals**

Unaudited Actuals are an annual statement reporting the financial activities of the District in which the data are not yet formally audited. Unaudited Actuals are presented to the Board each September, reflecting the District's final year end closing from the June 2020.

**Revenues**

AIMS is funded by state and federal revenues. Less than 5% of revenues are based on grants and/or local revenues. AIMS received \$15,471,322 in revenue for all schools. AIMS projected revenues at \$15,647,211 for the 2019-2020 fiscal year. This was 1% lower than projected. The primary factor was the "Stay in Place" order issued by Alameda County Health Department on March 16, 2020, followed up by the State-wide order issued March 19, 2020. Student and parent supported revenues such as donations and fundraising programs were impacted. Other delays, such as mail services and remote bank deposit services impacted the timely processing of revenue received. As we struggle to settle ourselves in these changing times, we have been able to recover and post the revenue received for 2019-2020 in the 2020-2021 fiscal year.

**Covid-19 Response**

Due to the "Stay in Place" order, beginning in April 2020 and for the remaining 2019-2020 school year, the Food Service program was impacted as AIMS students were being served through the Oakland Unified School District's Food Services program.

As required by the Measure G1 Parcel tax language, Measure G1 Staff Retention Salary Bonus reimbursement was issued to all schools.

	<b>LCFF</b>	<b>\$13,567,086</b>
	<b>Federal Revenue</b>	<b>\$813,764</b>
	<b>Other State Revenue</b>	<b>\$743,200</b>
	<b>Local Revenue</b>	<b>\$2,866,435</b>
	<b>Total Revenue</b>	<b>\$15,471,323</b>



**American Indian Model Schools**  
*A School at Work!*

**AIPCS I & II**  
 Downtown Oakland Campus

**AIPHS**  
 Lakeview Campus

171 12th Street  
 Oakland, CA 94607

746 Grand Avenue  
 Oakland, CA 94610

Phone: 510.893.8701  
 Fax: 510.893.0345  
 Website: aimschools.org

Phone: 510.893.8701  
 Fax: 510.893.0345  
 Website: aimschools.org

**Expenses**

American Indian Models Schools 2019-2020 budget reflects a 53% investment in Personnel expenses and 47% allocated to the operations of the organization. The total costs for the 2019-2020 school year are \$17,779,983.

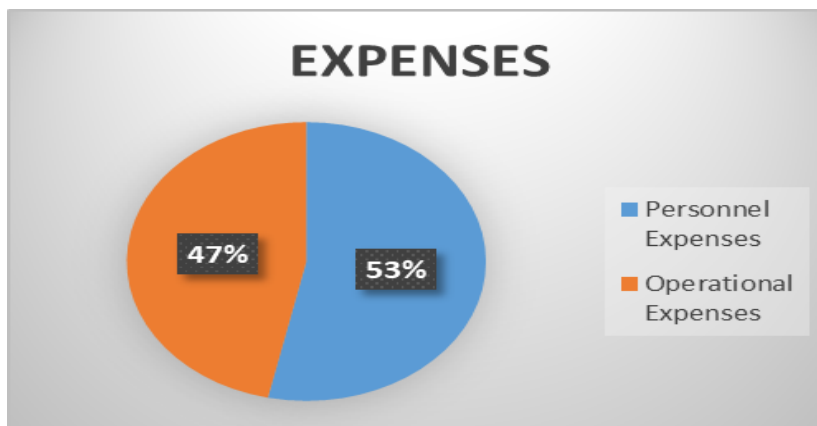

In September 2019, American Indian Models Schools acquired a loan in the amount of 9.3M. Allocating 5.7M to refinance the 12<sup>th</sup> Street property and 3.6M to upgrade the 12<sup>th</sup> Street campus. The cash available increased the projected spending for one-time expenses relating to the 12<sup>th</sup> street improvements.

**One-Time Expenses:**

- During the planning for the fiscal year 2019-2020, the housing requirements for AIMS Kindergarten and first-grade students increased. During the 2018-2019 fiscal year, the mentioned grades were housed at Roosevelt Middle School Campus, 1926 19<sup>th</sup> Avenue, a facility rented from our authorizer Oakland Unified School District. Once the school year began, those students had to be moved to the 12<sup>th</sup> street campus requiring upgrades to the property. To ensure an August 28 first day of school, work began at the end of the 2018-2019 and throughout July and August of the 2019-20 fiscal year requiring a short-term impact of \$1,424,557.71 to the Ending Fund balance at AIPCS II.
- American Indian Public High School Renovations were approved in January by the Board of Trustees to align with the mission and quality of education that AIMS strives for. The Board approved the \$106,704 purchase of desks, tables, and chairs.



**American Indian  
Model Schools**  
*A School at Work!*

**AIPCS I & II**  
*Downtown Oakland Campus*

**AIPHS**  
*Lakeview Campus*

171 12th Street  
Oakland, CA 94607

746 Grand Avenue  
Oakland, CA 94610

Phone: 510.893.8701  
Fax: 510.893.0345  
Website: aimschools.org

Phone: 510.893.8701  
Fax: 510.893.0345  
Website: aimschools.org

- In response to the "Stay in Place" order and to accommodate distance learning, all schools required an investment of \$299,738 for computers, communications, and software.
- March 2020, AIMS was informed that OUSD increased the Special Education SELPA rate by 23%. The per-pupil rate doubled halfway through the year.
- Unprecedented vacancies plagued the beginning of the 2019-2020 year. Substitute and recruitment costs were higher than projected. The positions have since been filled.

**Salaries & Benefits**

Salary compensation represents 53% of expenses across all American Indian Public Schools. AIMS offers a competitive compensation package for both certificated and classified staff. Employee Benefit expense at AIMS averages 19% across all schools. This can vary greatly due to two primary factors: health and welfare benefits and PERS. Health and welfare benefits (medical/dental/vision insurance premiums), if requested by the employee, can vary due to a number of factors, including an employee's age and the number of dependents. AIMS tracks and reports health and welfare benefits as precisely as possible and reflects as a variance in the percentage of benefits for employees at AIMS. PERS requires an employer contribution of 20.08% of classified salaries.

**AIPCS I**

Compensation for staff (excluding 6 teachers) at American Indian Public Charter (AIPCS) is split between AIPCS and the middle school component of American Indian Public Charter School II (6-8). The expenses reflected are divided by assignment and student Average Daily Attendance (ADA).

**AIPCS II**

American Indian Public Charter II (AIPCS II) is a K – 8. The staff for the K – 5 components are fully funded at AIPCS II, and the middle school component reflects the following Full-Time Equivalent (FTE) split:

AIPCS	44%
<u>AIPCS II</u>	<u>56%</u>
	100%



**American Indian  
Model Schools**  
*A School at Work!*

**AIPCS I & II**  
*Downtown Oakland Campus*

**AIPHS**  
*Lakeview Campus*

171 12th Street  
Oakland, CA 94607

746 Grand Avenue  
Oakland, CA 94610

Phone: 510.893.8701  
Fax: 510.893.0345  
Website: aimschools.org

Phone: 510.893.8701  
Fax: 510.893.0345  
Website: aimschools.org

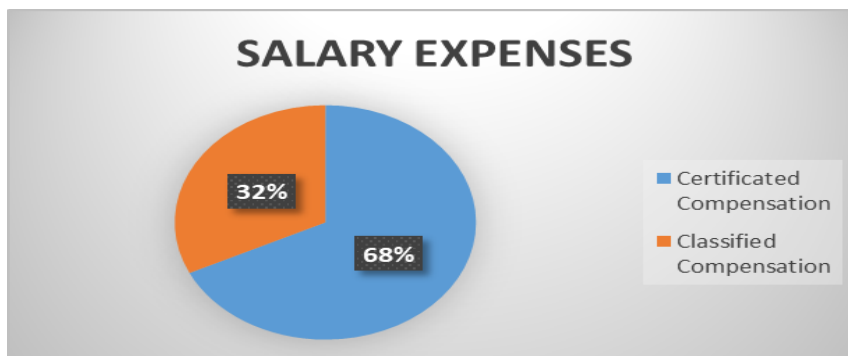

**Income Statement\***

100	Teachers' Salaries	\$3,916,325
120	Substitute Expense	\$77,478
1200	Certificated Pupil Support Salaries	\$275,004
1300	Certificated Supervisor and Administrator Salaries	\$945,443
<b>Certificated Salaries</b>		<b>\$5,214,251</b>
2100	Instructional Aide Salaries	\$767,885
2200	Classified Support Salaries (Maintenance, Food)	\$4,000
2300	Classified Supervisor and Administrator Salaries	\$356,213
2400	Clerical, Technical, and Office Staff Salaries	\$1,294,407
2900	Other Classified Salaries (Noon and Yard Sup, etc.)	\$20,069
<b>Classified Salaries</b>		<b>\$2,442,573</b>
3202	Public Employees' Retirement System, classified positions	\$498,361
3313	OASDI	\$460,598
3323	Medicare	\$108,884
3403	Health & Welfare Benefits	\$624,488
3503	State Unemployment Insurance	\$69,731
3603	Worker Compensation Insurance	\$31,526
3903	Other Employee Benefits	\$50,492
<b>Employee Benefits</b>		<b>\$1,844,080</b>
<b>Personnel Expenses</b>		<b>\$9,500,903</b>

**Books and Supplies**

Records expenditures for books and supplies, including any associated sales tax or use tax and freight and handling charges.





**American Indian  
Model Schools**  
*A School at Work!*

**AIPCS I & II**  
*Downtown Oakland Campus*

**AIPHS**  
*Lakeview Campus*

171 12th Street  
Oakland, CA 94607

746 Grand Avenue  
Oakland, CA 94610

Phone: 510.893.8701  
Fax: 510.893.0345  
Website: aimschools.org

Phone: 510.893.8701  
Fax: 510.893.0345  
Website: aimschools.org

The category of Book and Supplies captures more than classroom textbooks and materials. It itemizes Non-Capitalized student equipment such as tables, chairs, computers, and software.

*Renovation Projects*

During the 2019-2020 school year, AIPCS II (K-8) and the AIPHS (9-12) performed renovations to each of their campuses. All upgrades that were below the threshold of capitalization (**any individual asset purchase of \$5,000 or more**) are reflected in this category.

*Covid-19 Response*

**The Covid-19 response also had an impact on the increased investment in computers and software**

**For all schools, these expenses were one-time and are not projected in future years.**



4100	Approved Textbooks and Core Curricula Materials	\$ 263,714
4200	Books and Other Reference Materials	\$ 36,446
4300	Materials and Supplies	\$ 205,046
4315	Classroom Materials and Supplies	\$ 131,465
4316	Student/Pupil Testing	\$ 12,462
4342	Materials for School Sponsored Athletics	\$ 85,781
4381	Materials for Plant Maintenance	\$ 58,846
4400	Noncapitalized Equipment	\$ 515,837
4410	Computers/Network/Software	\$ 134,433
4430	Noncapitalized Student Equipment	\$ 600,712
4440	Student Events	\$ 5
4700	Food and Food Supplies	\$ 253,796
<b>Books and Supplies</b>		<b>\$ 2,298,544</b>

**Services and Other Operating Expenses**

Record expenditures for services, rentals, leases, maintenance contracts, dues, travel, insurance, utilities, and legal and other operating expenses. Expenditures may be authorized by contracts, agreements, purchase orders, and so forth.

*Covid-19 Response*

All schools reflect a 50% increase in expenses related to communications to support remote operations and distance learning.



American Indian  
Model Schools  
*A School at Work!*

**AIPCS I & II**

*Downtown Oakland Campus*

171 12th Street  
Oakland, CA 94607

Phone: 510.893.8701  
Fax: 510.893.0345  
Website: aimschools.org

**AIPHS**

*Lakeview Campus*

746 Grand Avenue  
Oakland, CA 94610

Phone: 510.893.8701  
Fax: 510.893.0345  
Website: aimschools.org

### *Renovation Projects*

For the renovation, \$929,902 in contractual obligations were funded from both the High School and the 12<sup>th</sup> Street campus projects.

### *Programmatic Adjustment*

At the beginning of the 2019-2020 school year, the High School experienced a large number of vacant positions. As the year progressed, each of these positions was permanently filled. Providing coverage for those positions produced a 60% increase in the projected cost during the prior school year. Salary savings from vacant positions were used to offset as much of the cost as possible.





**American Indian  
Model Schools**  
*A School at Work!*

**AIPCS I & II**  
Downtown Oakland Campus

**AIPHS**  
Lakeview Campus

171 12th Street  
Oakland, CA 94607

746 Grand Avenue  
Oakland, CA 94610

5200	Travel and Conferences	Phone: 510.893.8701	\$ 165,414
5210	Training and Development Expense	Fax: 510.893.0341	\$ 96,569
5300	Dues and Memberships	Website: amschools.org	\$ 18,759
5400	Insurance		\$ 108,063
5500	Operation and Housekeeping Services		\$ 8,482
5501	Utilities		\$ 247,881
5502	Janitorial Services		\$ 140,662
5504	Pest Control Services		\$ 7,028
5600	Space Rental/Leases Expense		\$ 156,322
5601	Building Maintenance		\$ 552,168
5602	Other Space Rental		\$ 68,581
5605	Equipment Rental/Lease Expense		\$ 70,171
5800	Professional/Consulting Services and Operating Expenditures		\$ 607,406
5803	Banking and Payroll Service Fees		\$ 36,307
5805	Legal Services and Audit		\$ 57,376
5806	Audit Services		\$ 26,200
5810	Educational Consultants		\$ 30,757
5811	Student Transportation		\$ 15,489
5812	Non employee substitutes		\$ 587,576
5815	Advertising/Recruiting		\$ 23,582
5820	Fundraising Expense		\$ 19,514
5821	Scholarship Expense		\$ 20,530
5822	Staff Appreciation - Non Public Funds		\$ 23,471
5830	Field Trip Expense		\$ 1,179
5836	Transportation Services		\$ 32
5842	Services Student Athletics		\$ 29,110
5873	Financial Services		\$ 242,108
5875	District Oversight Fee		\$ 135,671
5877	IT Services		\$ 48,758
5890	Interest Expense/Fees		\$ 3,628
5900	Communications (Tele., Internet, Copies, Postage, Messenger)		\$ 104,847
5901	Marketing		\$ 76,260
5910	Postage		\$ 916
5998	Unallocated Credit Card Expense		(\$ 0)
<b>Services &amp; Other Operating Expenses</b>			<b>\$ 3,730,815</b>

A charter management organization (CMO) is an educational organization that operates charter schools in the United States. Charter schools are public schools that operate independently of the local government school district.

A CMO controls all elements of the operation of the schools under its control, including holding the Charter. By convention, a CMO manages at least three schools. ([Wikipedia](#))

AIMS CMO supports functions such as District Leadership, Board, Human Resources, Fiscal Services, Facility and Food Operations, Registration and Enrollment, Parent Coordinator, Marketing Communications, Sports, and Routine Repair Maintenance Program.



**American Indian  
Model Schools**  
*A School at Work!*

**AIPCS I & II**  
*Downtown Oakland Campus*

**AIPHS**  
*Lakeview Campus*

171 12th Street  
Oakland, CA 94607

746 Grand Avenue  
Oakland, CA 94610

Phone: 510.893.8701  
Fax: 510.893.0345

Phone: 510.893.8701  
Fax: 510.893.0345

CMO INTERPROGRAM TRANSFER		
8785	CMO Management Fees	\$2,519,162
5899	CMO Management Fee Expense	\$2,519,162

## Capital Outlay

Capital Outlay records expenditures for land, buildings, books, and equipment, including leases with the option to purchase.

On September 18, 2018, the AIMS Board of Trustees voted to approve the leasing of 3 ten passenger vans to assist in the transportation of AIMS children for sports activities, field trips, and other instructional related activities. The vans are on a 60-month lease and impact capital outlay across all schools.

### *Renovation Projects*

Improvements to the 12<sup>th</sup> Street Campus during renovations met the capitalization criteria are reflected in this category.



6900	Depreciation Expense	\$291,969
<b>Capital Outlay</b>		<b>\$291,969</b>

## Other Outgo

### *Special Ed Mid-Year Adjustment*

AIMS partners with Oakland Unified School District to provide Special Education services for their students. AIMS does not receive revenue for the Special Education program, instead

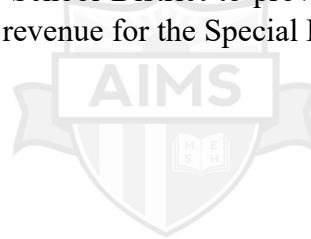

encroaches on the General Fund to pay OUSD to provide the needed services. In the first Quarter of the year, the cost per student was \$900. On March 2, 2020, AIMS was notified that the rate would increase to \$1,200 per student for the subsequent quarters. This unexpected increase averaged a 23% increase mid-year and required an additional \$287,353 across the program.





**American Indian Model Schools**  
*A School at Work!*

**AIPCS I & II**  
 Downtown Oakland Campus

**AIPHS**  
 Lakeview Campus

171 12th Street  
 Oakland, CA 94607

746 Grand Avenue  
 Oakland, CA 94610

741	Special Education Encroachment District	Phone: 510.893.8711 Fax: 510.893.0345	Phone: 510.893.8711 Fax: 510.893.0345
7438	Debt Service - Interest	Website: aimschools.org	Website: aimschools.org
<b>Other Outgo</b>			<b>\$1,957,753</b>

**Summary**

For the 2019-2020 school year, American Indian Model Schools received \$15,471,322 in revenue. The composition of those funds are as follows:

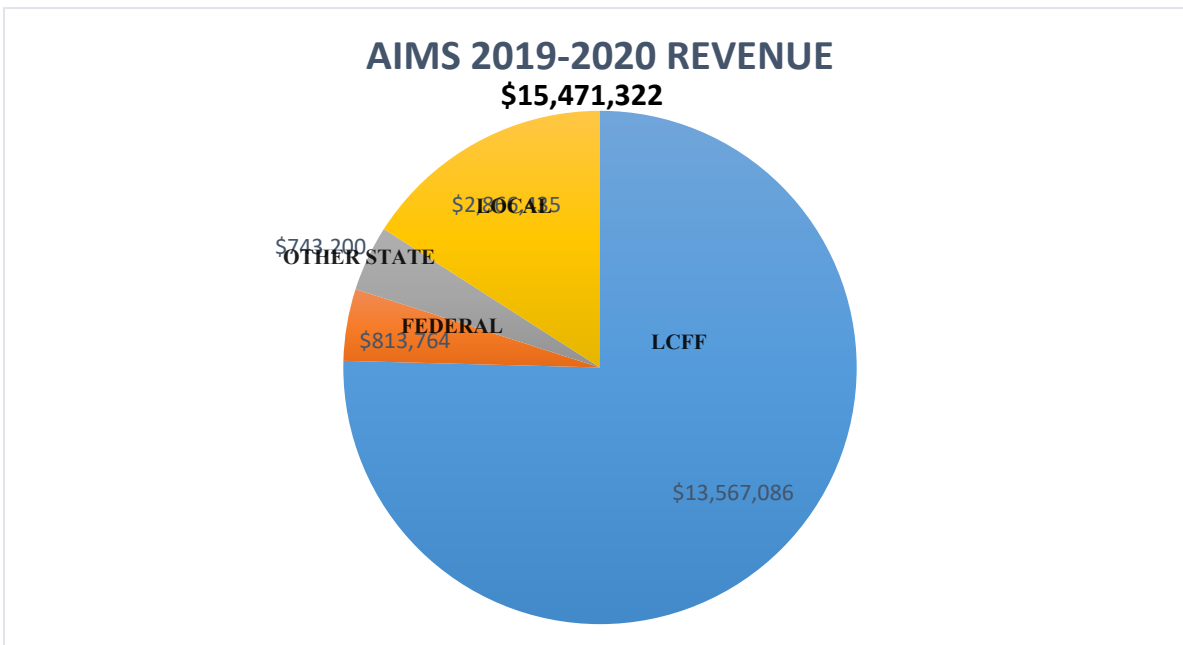

- Received revenue was 1% below budget projections
- Influential factors include: Stay in Place Order, Mail Disruption, reduced Property in Lieu tax for 4<sup>th</sup> Quarter



AIMS expensed \$17,779,983 during 2019-2020, resulting in excess of one-time spending of \$2,308,660. The factors that influenced the increased spending are listed below:



**American Indian  
Model Schools**  
*A School at Work!*

**AIPCS I & II**  
*Downtown Oakland Campus*  
171 12th Street  
Oakland, CA 94607

**AIPHS**  
*Lakeview Campus*  
746 Grand Avenue  
Oakland, CA 94610

<b>ONE-TIME EXPENSE FACTORS</b>		
<b>12th Street Renovations</b>	\$	<b>1,424,357.71</b>
<b>High School Renovation</b>	\$	<b>106,703.91</b>
<b>Special Ed Encroachment(mid-year adj)</b>	\$	<b>287,353.00</b>
<b>Covid-19 Response</b>	\$	<b>299,738.10</b>
<b>Increased program spending (subs)</b>	\$	<b>352,545.48</b>
<b>TOTAL ONE-TIME EXPENSE</b>	\$	<b>2,118,352.72</b>



**CASH FLOW STATEMENT**





**American Indian Model Schools**  
A School at Work!

**AIPCS I & II**  
Downtown Oakland Campus

**AIPHS**  
Lakeview Campus

171 12th Street  
Oakland, CA 94607

746 Grand Avenue  
Oakland, CA 94610

**American Indian Model Schools**

**Location: All**

		2019					
Cash Source / (Use)	July	August	September	October	November	December	
<b>Operating Activities</b>							
Revenue	\$2,209,745	\$636,426	\$848,520	\$1,423,813	\$1,411,485	\$795,825	
Expenses	(\$3,468,578)	(\$1,678,273)	(\$1,421,492)	(\$711,285)	(\$1,366,719)	(\$1,416,068)	
<b>Total Net (Loss)/Income</b>	<b>(\$1,258,833)</b>	<b>(\$1,041,847)</b>	<b>(\$572,972)</b>	<b>\$712,529</b>	<b>\$44,766</b>	<b>(\$620,243)</b>	
Receivables	\$258,046	\$399,658	\$267,675	\$280,141	\$255,111	\$222,317	
Intracompany Receivables	\$0	\$0	\$0	\$0	\$0	\$0	
Prepaid Expenses	\$0	\$0	\$0	\$6,923	\$0	\$0	
Current Other Expenses	\$0	\$0	\$0	\$0	\$0	\$0	
Other Assets	\$0	\$0	\$0	\$0	\$0	\$0	
Accounts Payables	\$2,500,681	(\$1,015,421)	(\$23,929)	(\$511,726)	(\$46,737)	(\$11,932)	
Accrued Salaries and Taxes	\$49,343	\$7,279	\$52,239	(\$49,959)	(\$21,517)	(\$4,411)	
Short Term Loans	\$0	\$0	\$0	\$0	\$0	\$0	
Deferred Revenue	\$0	\$0	\$0	\$0	\$0	\$0	
Other Current Liabilities	\$0	\$0	\$0	\$0	\$0	\$0	
<b>Net Cash provided/ (used) by Operating Activities</b>	<b>\$1,549,237</b>	<b>(\$1,650,331)</b>	<b>(\$276,988)</b>	<b>\$437,907</b>	<b>\$231,624</b>	<b>(\$414,270)</b>	
<b>Investing Activities</b>							
Capital Expenditures	\$0	\$0	\$0	(\$923,324)	\$0	\$0	
Other Investing Activities	\$0	\$0	\$0	\$0	\$0	\$0	
Equity Transfers	\$0	\$0	\$0	\$0	\$0	\$0	
<b>Net Cash provided/ (used) by Investing Activities</b>	<b>\$0</b>	<b>\$0</b>	<b>\$0</b>	<b>(\$923,324)</b>	<b>\$0</b>	<b>\$0</b>	
<b>Financing Activities</b>							
Cash Flow Financing - Secured Debt	\$0	\$0	\$0	\$0	\$0	\$0	
Loan Payables	(\$10,086)	(\$10,086)	\$3,568,014	\$0	(\$16,086)	(\$16,086)	
Deferred Lease Expense	(\$1,504)	(\$1,504)	(\$1,504)	(\$1,504)	(\$1,504)	(\$1,504)	
<b>Net Cash provided/ (used) by Financing Activities</b>	<b>(\$11,590)</b>	<b>(\$11,590)</b>	<b>\$3,566,510</b>	<b>(\$1,504)</b>	<b>(\$17,590)</b>	<b>(\$17,590)</b>	
Cash at Beginning of Period	\$2,635,721	\$4,173,369	\$2,511,448	\$5,800,971	\$5,314,051	\$5,528,085	
<b>Net Increase/(Decrease) in Cash</b>	<b>\$1,537,647</b>	<b>(\$1,661,921)</b>	<b>\$3,289,523</b>	<b>(\$486,920)</b>	<b>\$214,034</b>	<b>(\$431,860)</b>	
<b>Cash at end of Period</b>	<b>\$4,173,369</b>	<b>\$2,511,448</b>	<b>\$5,800,971</b>	<b>\$5,314,051</b>	<b>\$5,528,085</b>	<b>\$5,096,225</b>	





**American Indian Model Schools**  
A School at Work!

**AIPCS I & II**  
Downtown Oakland Campus

**AIPHS**  
Lakeview Campus

171 12th Street  
Oakland, CA 94607

746 Grand Avenue  
Oakland, CA 94610

Phone: 510.893.8701  
Fax: 510.893.0345  
Website: aimschools.org

Phone: 510.893.8701  
Fax: 510.893.0345  
Website: aimschools.org

**American Indian Model Schools**  
**Location: All**

<b>2020</b>
-------------

	Cash Source / (Use)	January	February	March	April	May	June
Operating Activities	Revenue	\$2,000,746	\$902,722	\$756,691	\$1,399,783	\$836,594	\$4,768,134
	Expenses	(\$1,722,178)	(\$1,635,532)	(\$1,150,263)	(\$1,180,794)	(\$1,056,026)	(\$3,491,937)
	Total Net (Loss)/Income	\$278,569	(\$732,810)	(\$393,572)	\$218,989	(\$219,432)	\$1,276,197
	Receivables	\$285,295	\$230,220	\$224,723	\$195,205	\$32,584	(\$3,895,914)
	Intracompany Receivables	\$0	\$0	\$0	\$0	\$0	\$0
	Prepaid Expenses	\$0	\$0	(\$12,834)	\$0	\$0	(\$44,599)
	Current Other Expenses	\$0	\$0	\$0	\$0	\$0	\$0
	Other Assets	\$0	\$0	\$0	\$0	\$0	\$0
	Accounts Payables	(\$541,419)	(\$221,928)	(\$349,456)	(\$13,608)	(\$216,271)	\$310,334
	Accrued Salaries and Taxes	\$230	(\$6,973)	\$29,029	\$23,572	(\$87,221)	(\$44,815)
	Short Term Loans	\$0	\$0	\$0	\$0	\$0	\$0
	Deferred Revenue	\$0	\$0	\$0	\$0	\$0	\$46,038
	Other Current Liabilities	\$0	\$0	\$0	\$0	\$0	\$0
	<b>Net Cash provided/ (used) by Operating Activities</b>	<b>\$22,675</b>	<b>(\$731,491)</b>	<b>(\$502,110)</b>	<b>\$424,158</b>	<b>(\$490,341)</b>	<b>(\$2,352,760)</b>
Investing Activities	Capital Expenditures	\$0	\$0	\$0	\$0	(\$5,600)	\$291,969
	Other Investing Activities	\$0	\$0	\$0	\$0	\$0	\$0
	Equity Transfers	\$0	\$0	\$0	\$0	\$0	\$0
	<b>Net Cash provided/ (used) by Investing Activities</b>	<b>\$0</b>	<b>\$0</b>	<b>\$0</b>	<b>\$0</b>	<b>(\$5,600)</b>	<b>\$291,969</b>
Financing Activities	Cash Flow Financing - Secured Debt	\$0	\$0	\$0	\$0	\$0	\$0
	Loan Payables	(\$16,086)	(\$16,086)	(\$16,086)	\$1,906,314	(\$16,086)	(\$16,086)
	Deferred Lease Expense	(\$1,504)	(\$1,504)	(\$1,504)	(\$1,504)	(\$1,504)	(\$1,504)
	<b>Net Cash provided/ (used) by Financing Activities</b>	<b>(\$17,590)</b>	<b>(\$17,590)</b>	<b>(\$17,590)</b>	<b>\$1,904,810</b>	<b>(\$17,590)</b>	<b>(\$17,590)</b>
	Cash at Beginning of Period	\$5,096,225	\$5,101,310	\$4,352,230	\$3,832,530	\$6,161,498	\$5,647,968
<b>Net Increase/(Decrease) in Cash</b>		<b>\$5,085</b>	<b>(\$749,080)</b>	<b>(\$519,700)</b>	<b>\$2,328,968</b>	<b>(\$513,530)</b>	<b>(\$2,078,381)</b>
<b>Cash at end of Period</b>		<b>\$5,101,310</b>	<b>\$4,352,230</b>	<b>\$3,832,530</b>	<b>\$6,161,498</b>	<b>\$5,647,968</b>	<b>\$3,569,587</b>



## Notice

The following file is attached to this PDF. You will need to open this packet in an application that supports attachments to pdf files, e.g. [Adobe Reader](#):

01612590114363 (1) signed.xlsm



## AIMS Board Meeting Item Cover Letter

Item:

Presented By:

Staff Recommendation:

Committee Approval:

Total Associated Cost:

Included in Budget?

Over or Under Budget?

Amount Over/Under Budget?

Included in LCAP?

Which LCAP?

## Notice

The following file is attached to this PDF. You will need to open this packet in an application that supports attachments to pdf files, e.g. [Adobe Reader](#):

01612596113807 (1) signed.xlsm

# Coversheet

## Cyber Security Insurance Renewal

**Section:** III. Action Items  
**Item:** B. Cyber Security Insurance Renewal  
**Purpose:** Vote  
**Submitted by:**  
**Related Material:** Cyber Liability Axis '20 with invoice for finance.pdf  
AIMS Finance Comittee Cover 2020 21 Cyber Polciy Ins Renewal.pdf



**AMERICAN INDIAN MODEL SCHOOLS  
CYBER LIABILITY  
10/21/2020**

**Company:** Axis Pro PrivaSure Insurance Company is an Admitted company in California with a financial rating of 'A+' (**Superior**) as rated by A.M. Best, insurance rating source. The Company is based in Alpharetta, GA.

**CYBER LIABILITY – (claims made) retroactive date is the effective date**

\$ 1,000,000	Aggregate Limit of Liability
\$ 1,000,000	Enterprise Security Event Limit
\$ 1,000,000	Privacy Regulation Claim Limit
\$ 1,000,000	Crisis Management Expense Limit
\$ 1,000,000	Fraud Response Expense Limit
\$ 1,000,000	Public Relations Expense Limit
\$ 1,000,000	Forensic and Legal Expense Limit
\$ 1,000,000	Extortion Loss Limit
\$ 1,000,000	System Disruption – Business Interruption Coverage Limit
\$ 1,000,000	Data System Expense Limit (6 hour waiting period)
\$ 1,000,000	PCI-DSS Fines Claims Limit
\$ 1,000,000	Website Media Limit
\$ 1,000,000	Ransomware Loss Limit
\$ 250,000	Social Engineering Fraud Loss Limit
\$ 250,000	Telecommunications Theft Loss Limit
\$ 5,000	Retention



<b>COST SUMMARY:</b>	\$ 3,150.00	Premium
	\$ 100.00	Broker fee
	<b>\$ 3,250.00</b>	<b>Total (Down Payment is \$888)</b>

**PAY NOW**  
CLICK HERE

Note: This is a summary. See policy for, insuring agreements, definitions and exclusions.

*AIMS NOT BE ISSUE PAYMENT UNTIL APPROVED BY BOARD ON SEPTEMBER 15, 2020*



**INVOICE**  
7/29/2020

American Indian Model Schools  
171 12<sup>th</sup> Street, Suite 200  
Oakland, CA 94607

Attn: Jack Huang jack.huang@aimsk12.org

---

<u>DESCRIPTION</u>	<u>AMOUNT</u>
Cyber Liability	\$ 3,150
Broker Fee	\$ 100

PAY BY CREDIT CARD HERE:



-OR-

PLEASE MAKE CHECK PAYABLE TO: ALL-CAL INSURANCE AGENCY  
505 VERNON STREET  
ROSEVILLE, CA 95678

<b>TOTAL</b>	<b>\$ 3,250</b>
--------------	-----------------

---

505 VERNON STREET ♦ ROSEVILLE, CA 95678 ♦ (800) 841-1776 TOLL FREE ♦ (916) 784-0158 FAX  
[www.all-calinsurance.com](http://www.all-calinsurance.com) ♦ LICENSE #OB71044



## AIMS Board Meeting Item Cover Letter

Item:

Presented By:

Staff Recommendation:

Committee Approval:

Total Associated Cost:

Included in Budget?

Over or Under Budget?

Amount Over/Under Budget?

Included in LCAP?

Which LCAP?



# Coversheet

## General Liability Insurance Renewal

**Section:** III. Action Items  
**Item:** C. General Liability Insurance Renewal  
**Purpose:** Vote  
**Submitted by:**  
**Related Material:** General Liability Insurance Renewal 2020.pdf  
AIMS Finance Committee Cover 2020 21 General Liability Ins Renewal.pdf



**AMERICAN INDIAN MODEL SCHOOLS  
PACKAGE RENEWAL SUMMARY  
9/01/2020**



**Great American Assurance Company, Specialty Human Services Division** is an American company headquartered in Cincinnati, OH. The company is an 'A' (**excellent**) rated carrier by A.M. Best insurance rating source. [www.hsd.gaic.com](http://www.hsd.gaic.com)  
Great American is also one of leading companies in providing safety and loss prevention services for their policyholders.

**LIABILITY (Occurrence form)**

\$ 2,000,000 Commercial General Liability Aggregate  
 \$ 2,000,000 Products - Completed Operations  
 \$ 1,000,000 Personal and Advertising Injury  
 \$ 1,000,000 Professional Liability  
 \$ 1,000,000 Abuse and Molestation Coverage  
 \$ 1,000,000 *Employee Benefits Liability*  
 \$ 1,000,000 Each Occurrence  
 \$ 1,000,000 Damage to premises rented to you  
 \$ 20,000 Premises Medical  
 \$ 0 Deductible

**Locations:**

- 1) 171 12<sup>th</sup> St
- 2) 746 Grand Ave
- 3) 1101 Marina Village Pkwy #270

**General Liability Broadening Endorsement:**

Human Services Violent Event Response \$250,000  
 Additional Insureds – Manager or Lessor of Premises, Volunteer Workers, Funding Sources, Contractual Obligations.  
 Blanket Waiver of Subrogation  
 Broadened Personal Injury – Mental Injury, Mental Anguish, Humiliation or Shock included in the definition of Bodily Injury.  
 Bail Bond - \$500 Maximum  
 Insured’s Expenses incurred in defense of a claim or “suit” - \$500 per day

---

505 VERNON STREET ♦ ROSEVILLE, CA 95678 ♦ (800) 841-1776 TOLL FREE ♦ (916) 784-0158 FAX  
 LICENSE #OB71044 ♦ [www.all-calinsurance.com](http://www.all-calinsurance.com) ♦ Proudly specializing in Nonprofit Organizations since 1989



**UMBRELLA:** (covers over the General Liability, General Aggregate, Professional Liability, Abuse and Molestation, Auto)

\$ 4,000,000 Each Occurrence  
 \$ 10,000 Retained Limit (deductible)

**AUTO:**

\$ 1,000,000 Liability  
 \$ 1,000,000 Uninsured Motorists  
 \$ 1,000,000 Non-owned & Hired Auto Liability  
 \$ 5,000 Medical Payments  
 \$ 500 Comprehensive Deductible  
 \$ 500 Collision Deductible

**Vehicles:**

2019 Ford Transit  
 2019 Ford Transit  
 2019 Ford Transit

**Comp and Collision**

yes added 2019  
 yes added 2019  
 yes added 2019

**PROPERTY:**

*171 12<sup>th</sup> Street*

Building \$ 8,901,784  
 Business property \$ 890,174

*746 Grand Ave*

Business property \$ 150,000



1101 Marina Village Pkwy

Business property \$ 5,200

**Property Broadening Endorsement:**

Business Income with extra expense	Included
Accounts Receivable	Included
Valuable papers	Included
Business Electronic Systems	Included
Arson Reward	\$ 50,000
Identity Theft	\$ 50,000
Spoilage	\$ 50,000
Workplace violence counseling	\$ 50,000
Water back up of sewer or drains	\$ 30,000
Communicable Disease	\$ 25,000
Employee Theft	\$ 10,000
Forgery or Alteration	\$ 2,500
Computer and Funds transfer	\$ 2,500
Property off premises	\$ 500,000
Property in transit	\$ 100,000
Money & Securities	\$ 2,500
Signs	\$ 50,000

**Equipment Breakdown \$ 10,197,158**



**CRIME:**

Employee Theft	\$ 50,000
Forgery & Alteration	\$ 50,000

The above includes fire & theft with replacement cost on contents. No flood or earthquake quoted. The deductible is **\$1,000**.

**COST SUMMARY:**

\$ 38,418.00	Package-Liability, Property & Crime	
\$ 13,061.25	Auto	
\$ 9,249.00	Umbrella	
\$ 150.00	Broker fee	
<b>\$ 60,878.25</b>	<b>Total</b>	<b>Amount due now \$150</b>



*Note: This is a summary. See policy for definitions, insuring agreements, and exclusions.*

**OPTIONS: COVERAGE ESTIMATES NOT INCLUDED IN ABOVE PRICING, BUT AVAILABLE (priced above)**

- \$ 450.00 Increasing Crime coverage to \$100,000 (higher limits are available)
- \$ 3,000.00 Reducing Umbrella - If funding is diminished and on campus enrollment is down.

**Also available:** Group medical, dental, Earthquake, Flood etc.



## AIMS Board Meeting Item Cover Letter

Item:

Presented By:

Staff Recommendation:

Committee Approval:

Total Associated Cost:

Included in Budget?

Over or Under Budget?

Amount Over/Under Budget?

Included in LCAP?

Which LCAP?

# Coversheet

## Pre-Approved Vendor List

**Section:** III. Action Items  
**Item:** D. Pre-Approved Vendor List  
**Purpose:** Vote  
**Submitted by:**  
**Related Material:** 2020-2021 Pre-approved Vendor List (1).pdf  
AIMS Finance Committee Cover 2020-2021 Approved Vendor List.pdf

**Vendor List**  
Pre-Approved 2018-19

American Indian Model Schools  
2020-2021 Vendor List

<u>VENDOR</u>	<u>SERVICE TYPE</u>	<u>Payment Source</u>	<u>Billing Cycle</u>	<u>Requirements</u>
Acme Fire Extinguisher Co.	Fire Extinguisher	LCFF - Unrestricted	Point of Service	
Aflac	Health & Welfare	LCFF - Unrestricted	Payroll Deduction	Employee Elected Benefit
Alameda County Property Tax	Operations	LCFF - Unrestricted	Annual Requirement	County Required
Allcal Insurance Co	Insurance	LCFF - Unrestricted	Contract	Insurance Broker
APPLE Inc:	Technology	LCFF - Unrestricted	Contract	
AT&T	Communication	LCFF - Unrestricted	Contract	12th Street Phones
AT&T Wireless	Communication	LCFF - Unrestricted	Contract	12th Street Garage
Bay Area Community Resoruce (BACR)	Afterschool	LCFF - Unrestricted/ASES	Contract	Afterschool Program Fudned by ASES: State Compliance
Berkshire Hathaway Oak River	Workers Comp	LCFF - Unrestricted	Contract	Workers Comp Program: Compliance
California State Disbursement Unit	Garnishments/CH Supp	LCFF - Unrestricted	Payroll Deduction	
CALPERS:	Retirement	LCFF - Unrestricted	Payroll Deduction	
Capital Prem D&O loan 288122	Directors/Officers Ins	LCFF - Unrestricted	Contract	Directors and Officers Insurance
Charter Schools Association	Dues & Memberships	LCFF - Unrestricted	Annual Payment	Membership for Professional Development
Charter School Management Corp	Back office support	LCFF - Unrestricted	Contract	Back office Support
Clark Pest Control	Routine Repair/Maint	LCFF - Unrestricted	Point of Service	
CLM Group, Inc/ Mealtime	Lunch Program	Meal Revenue/Federal Reimb	Contract	
Comcast	Communication/Internet	LCFF - Unrestricted	Contract	12th Street Internet
Comcast Business 939756933	Communication/Internet	LCFF - Unrestricted	Contract	12th Street Internet
East West Bank-Mortgage	Housing	LCFF - Unrestricted	Contract	12th Street Housing
EBMUD	Housing	LCFF - Unrestricted	Contract	12th Street Water
Elan Corporate-Credit Cards	Credit Card	EFT - LCFF Unrestricted	Point of Service	
Fire & Security Alarm Company	Alarm Services	LCFF - Unrestricted	Contract	
Franchise Tax Board	Operations	LCFF - Unrestricted	Point of Service	As Billed
Great American Insurance Co.	Property/Liability	LCFF - Unrestricted	Contract	Property & Liabaility Insurance
Illuminate	Student License Software	LCFF - Unrestricted	Contract	
Kaiser Permanente	Health & Welfare	EFT - LCFF Unrestricted	Contract	Employee Health Benefits
MRC	Copier Leases	LCFF - Unrestricted	Contract	
National Payment Center(Us Dept of Ed)	Federal Finance Requests	EFT - LCFF Unrestricted	Point of Service	As Billed
Nob Hill Catering Inc	Lunch Program	Meal Revenue/Federal Reimb	Contract	
OUSD-Rent Lakeview only	Housing	LCFF - Unrestricted	Contract	Prop 39 MOU with OUSD
Paramount Elevator	Routine Repair/Maint	LCFF - Unrestricted	Contract	Routine Repair Maint
PAYBRIDGE-INVOICE	Payroll Processing	LCFF - Unrestricted	Contract	12th Street Payroll Processing
PAYROLL TAX-PAYBRIDGE	Payroll Processing	LCFF - Unrestricted	Contract	12th Street Payroll Processing
PG & E	Electricity and Gas	LCFF - Unrestricted	Contract	12th Street Energy
Regional Employee Benefits Council	Health & Welfare	LCFF - Unrestricted	Payroll Deduction	Health and Welfare Broker
Regus Management	Housing	LCFF - Unrestricted	Contract	Central Office Rental
Rojas Janitorial Service	Cleaning Services	LCFF - Unrestricted	Point of Service	
School Food Solution	Back office Support - Food Srv	LCFF - Unrestricted	Contract	
Staples Advantage	School Supplies	LCFF - Unrestricted	Point of Service	Office and School Supplies
State Board of Equalizations	State Taxes	LCFF - Unrestricted	Point of Service	As Billed
Swing Education	Subs for Teachers	LCFF - Unrestricted	Contract/Point of Service	Subs for teachers
TEC Lease:	Transportation	LCFF - Unrestricted	Contract	Van Lease
ThinkHR	Recruitment	LCFF - Unrestricted		
US Bank Equipmnt Finance	Copier Leases	LCFF - Unrestricted	Contract	



**Vendor List**  
Pre-Approved 2018-19

Verizon Wireless (Manual Checks)	Communication	LCFF - Unrestricted	Contract	Internet/Office and Cell Phone
Verizon Wireless (Auto Deductions)	Communication	LCFF - Unrestricted	Contract	Internet/Office and Cell Phone
VSP Vision Insurance	Health & Welfare	EFT - LCFF - Unrestricted	Payroll Deduction	Employee Health and Welfare Insurance
Eide Bailey (Formerly VTD)	Audit Services	LCFF - Unrestricted	Contract	Auditing Services
Waste Management	Routine Repair/Maint	LCFF - Unrestricted	Contract	12th Street Garbage
Xerox Corporation	Copier Leases	LCFF - Unrestricted	Contract	
Xerox Financial Services	Copier Leases	LCFF - Unrestricted	Contract	Copier Leases Program
YMC	Legal	LCFF - Unrestricted	Point of Service	12th Street Water
Young, Minney & Corp , LLP	Legal Services	LCFF - Unrestricted	Point of Service	



## AIMS Board Meeting Item Cover Letter

Item:

Presented By:

Staff Recommendation:

Committee Approval:

Total Associated Cost:

Included in Budget?

Over or Under Budget?

Amount Over/Under Budget?

Included in LCAP?

Which LCAP?

# Coversheet

## Window Installation for 12th Street

**Section:** III. Action Items  
**Item:** E. Window Installation for 12th Street  
**Purpose:** Vote  
**Submitted by:**  
**Related Material:** 3rd Floor Evacuation Plan - (2020-2021).pdf  
2nd Floor Evacuation Plan - (2020-2021).pdf  
1st Floor Evacuation - (2020-2021).pdf  
AMA Glass Certificate of Liability (1).pdf  
AMA Glass Quote (1).pdf  
insurance certificate (1).pdf  
Different Group Glass.pdf  
Window Sample Picture.pdf  
Window Installation - Cover Letter (1).pdf

# Third Floor Evacuation Map

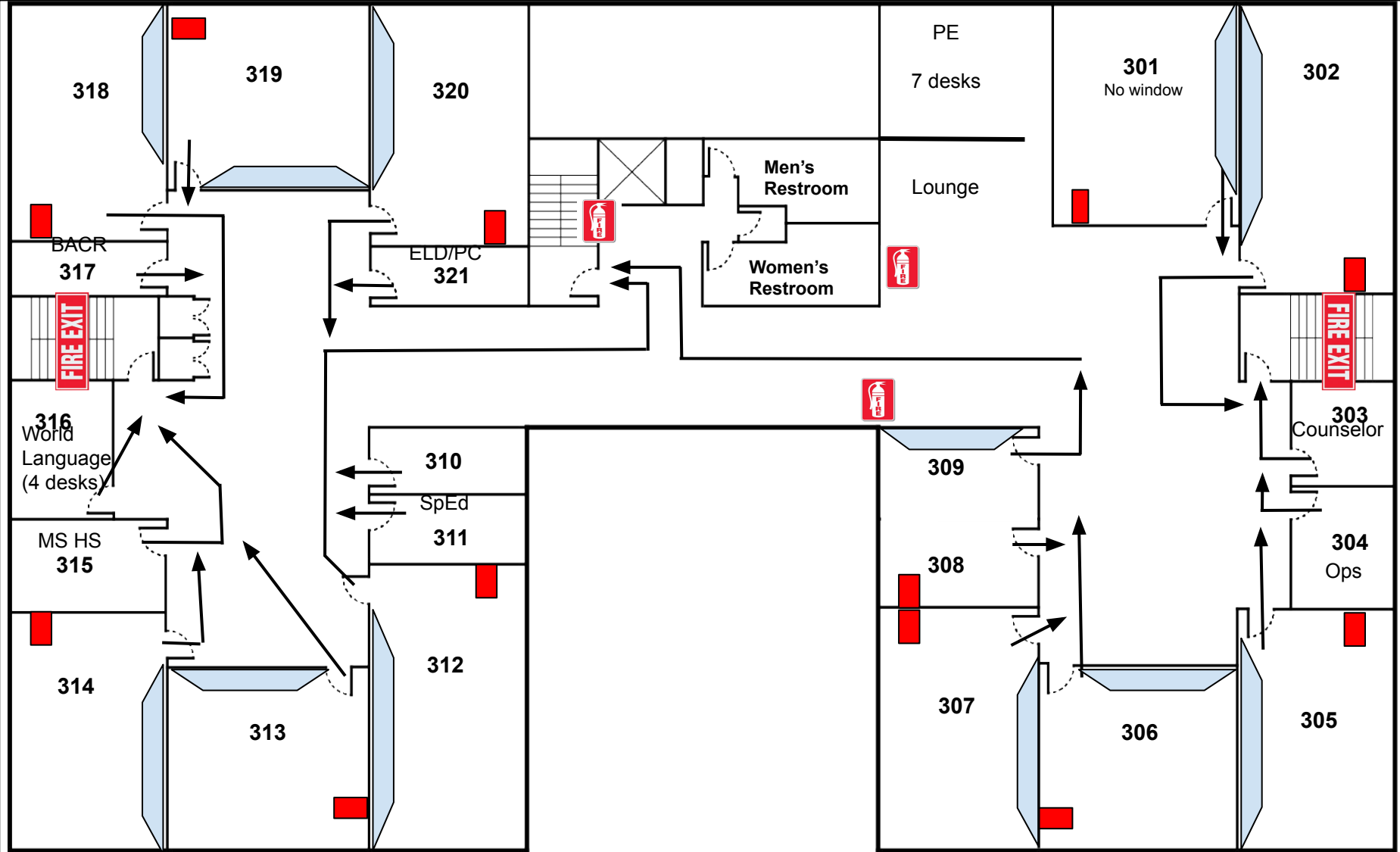

East Wing

2nd Floor Evacuation Map

West Wing

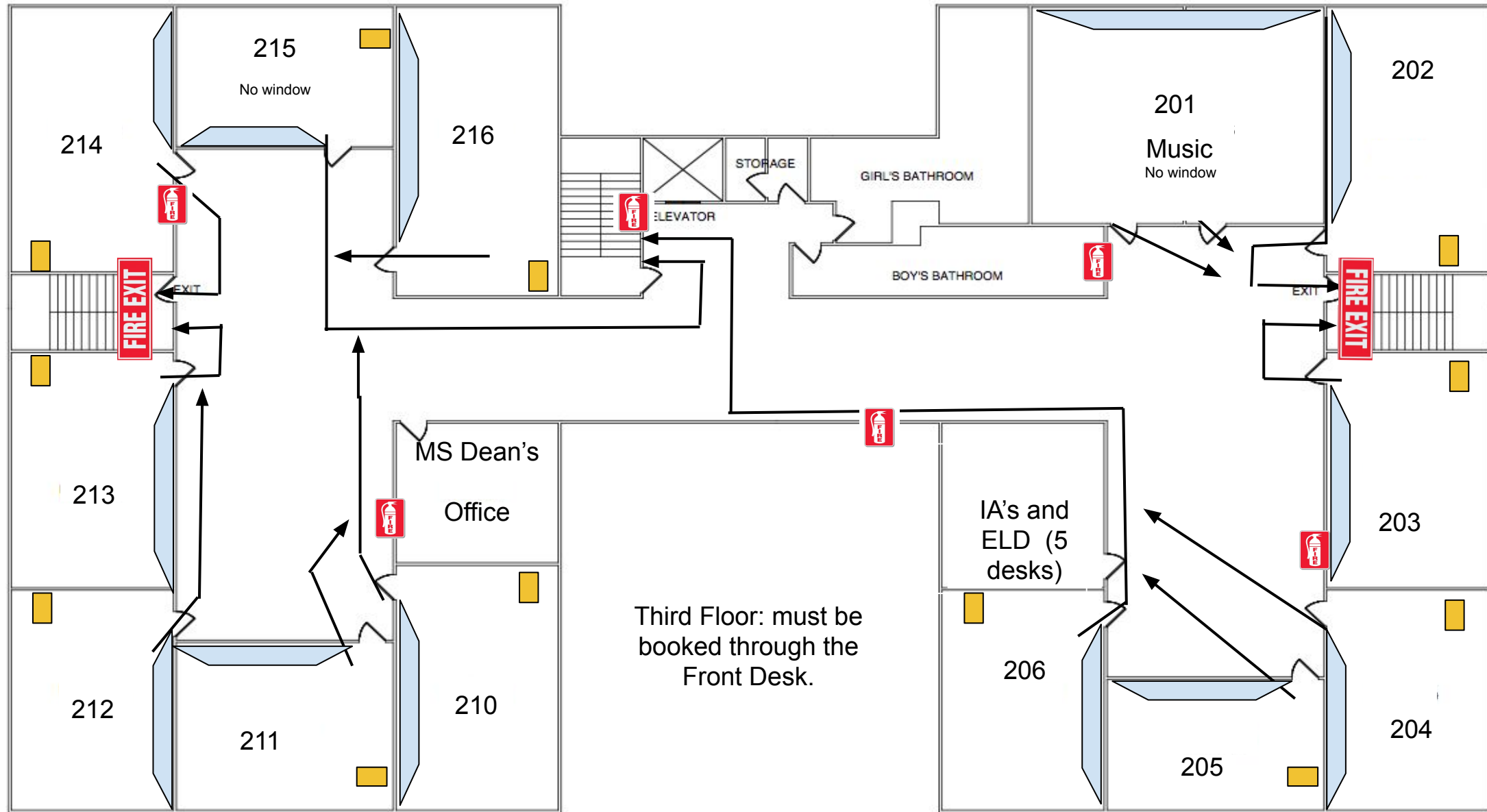

12TH STREET

First Floor Evacuation Map

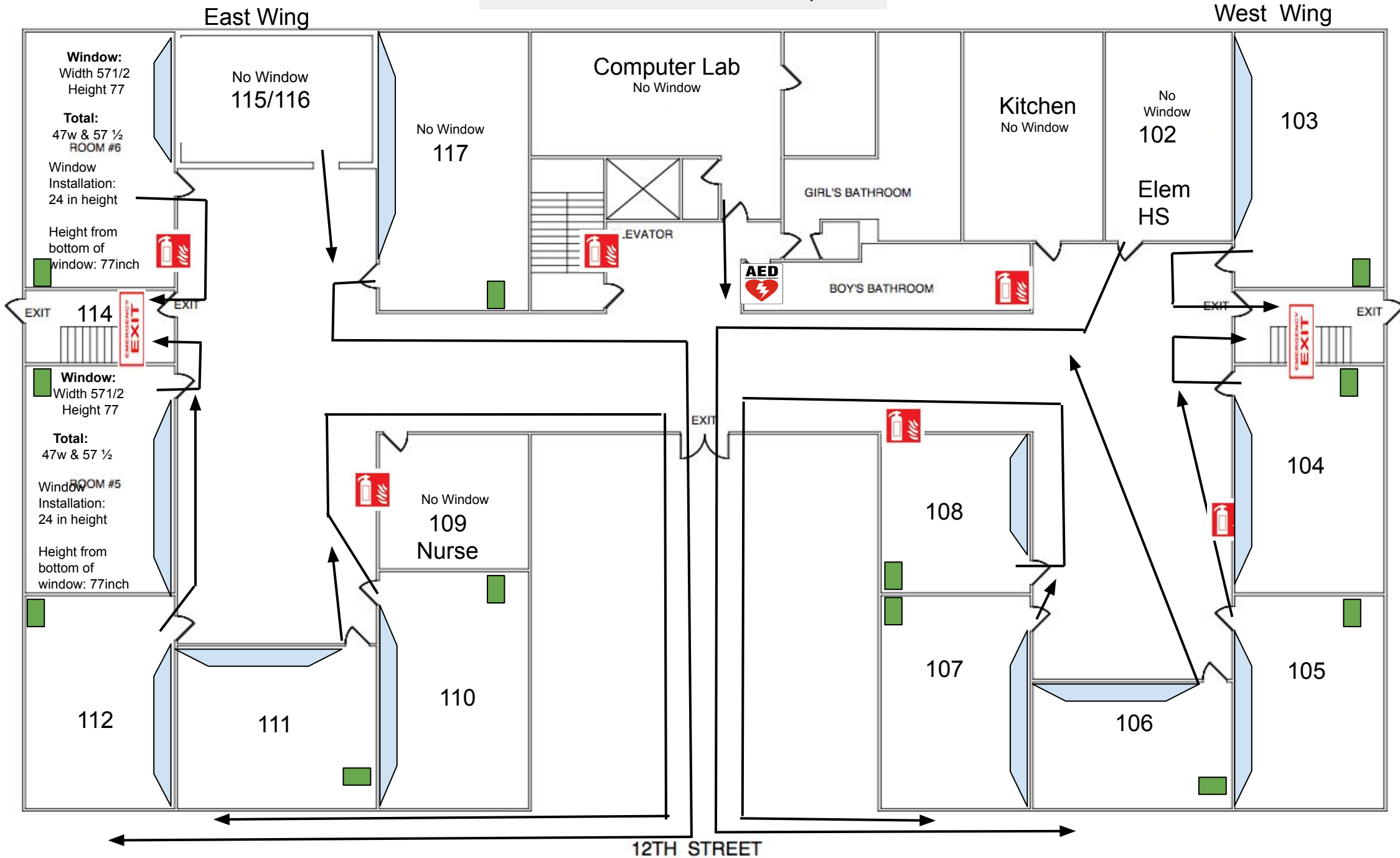

12TH STREET



# CERTIFICATE OF LIABILITY INSURANCE

DATE (MM/DD/YYYY)  
03/23/2020

**THIS CERTIFICATE IS ISSUED AS A MATTER OF INFORMATION ONLY AND CONFERS NO RIGHTS UPON THE CERTIFICATE HOLDER. THIS CERTIFICATE DOES NOT AFFIRMATIVELY OR NEGATIVELY AMEND, EXTEND OR ALTER THE COVERAGE AFFORDED BY THE POLICIES BELOW. THIS CERTIFICATE OF INSURANCE DOES NOT CONSTITUTE A CONTRACT BETWEEN THE ISSUING INSURER(S), AUTHORIZED REPRESENTATIVE OR PRODUCER, AND THE CERTIFICATE HOLDER.**

**IMPORTANT: If the certificate holder is an ADDITIONAL INSURED, the policy(ies) must be endorsed. If SUBROGATION IS WAIVED, subject to the terms and conditions of the policy, certain policies may require an endorsement. A statement on this certificate does not confer rights to the certificate holder in lieu of such endorsement(s).**

<b>PRODUCER</b> Abdul Shah 9355 East Stockton Blvd Suite 260  Elk Grove CA 95624	<b>CONTACT NAME:</b> PHONE (A/C, No, Ext): 916-770-4200      FAX (A/C, No): 916-209-9690 E-MAIL ADDRESS: coastinsuranceagency@gmail.com																					
<b>INSURED</b>  Bahman Shababi DBA AMA Glass 3080 Broadway,  Oakland CA 94611	<table border="1" style="width:100%; border-collapse: collapse;"> <tr> <th colspan="2">INSURER(S) AFFORDING COVERAGE</th> <th>NAIC #</th> </tr> <tr> <td>INSURER A:</td> <td>United States Liability Insurance Company</td> <td></td> </tr> <tr> <td>INSURER B:</td> <td></td> <td></td> </tr> <tr> <td>INSURER C:</td> <td></td> <td></td> </tr> <tr> <td>INSURER D:</td> <td></td> <td></td> </tr> <tr> <td>INSURER E:</td> <td></td> <td></td> </tr> <tr> <td>INSURER F:</td> <td></td> <td></td> </tr> </table>	INSURER(S) AFFORDING COVERAGE		NAIC #	INSURER A:	United States Liability Insurance Company		INSURER B:			INSURER C:			INSURER D:			INSURER E:			INSURER F:		
INSURER(S) AFFORDING COVERAGE		NAIC #																				
INSURER A:	United States Liability Insurance Company																					
INSURER B:																						
INSURER C:																						
INSURER D:																						
INSURER E:																						
INSURER F:																						

**COVERAGES**

**CERTIFICATE NUMBER:**

**REVISION NUMBER:**

THIS IS TO CERTIFY THAT THE POLICIES OF INSURANCE LISTED BELOW HAVE BEEN ISSUED TO THE INSURED NAMED ABOVE FOR THE POLICY PERIOD INDICATED. NOTWITHSTANDING ANY REQUIREMENT, TERM OR CONDITION OF ANY CONTRACT OR OTHER DOCUMENT WITH RESPECT TO WHICH THIS CERTIFICATE MAY BE ISSUED OR MAY PERTAIN, THE INSURANCE AFFORDED BY THE POLICIES DESCRIBED HEREIN IS SUBJECT TO ALL THE TERMS, EXCLUSIONS AND CONDITIONS OF SUCH POLICIES. LIMITS SHOWN MAY HAVE BEEN REDUCED BY PAID CLAIMS.

INSR LTR	TYPE OF INSURANCE	ADDL INSR	SUBR WVD	POLICY NUMBER	POLICY EFF (MM/DD/YYYY)	POLICY EXP (MM/DD/YYYY)	LIMITS
B	<b>GENERAL LIABILITY</b>			CL174889D	03/08/2020	03/08/2021	EACH OCCURRENCE \$ 1,000,000
	<input checked="" type="checkbox"/> COMMERCIAL GENERAL LIABILITY						DAMAGE TO RENTED PREMISES (Ea occurrence) \$ 100,000
	<input type="checkbox"/> CLAIMS-MADE <input checked="" type="checkbox"/> OCCUR						MED EXP (Any one person) \$ 5,000
	GEN'L AGGREGATE LIMIT APPLIES PER:						PERSONAL & ADV INJURY \$ 1,000,000
	<input checked="" type="checkbox"/> POLICY <input type="checkbox"/> PRO-JECT <input type="checkbox"/> LOC						GENERAL AGGREGATE \$ 2,000,000
	<b>AUTOMOBILE LIABILITY</b>						PRODUCTS - COMP/OP AGG \$ 2,000,000
	<input type="checkbox"/> ANY AUTO						Deductible \$ 500
	<input type="checkbox"/> ALL OWNED AUTOS	<input type="checkbox"/> SCHEDULED AUTOS					COMBINED SINGLE LIMIT (Ea accident) \$
	<input type="checkbox"/> HIRED AUTOS	<input type="checkbox"/> NON-OWNED AUTOS					BODILY INJURY (Per person) \$
	<b>UMBRELLA LIAB</b>	<input type="checkbox"/> OCCUR					BODILY INJURY (Per accident) \$
	<b>EXCESS LIAB</b>	<input type="checkbox"/> CLAIMS-MADE					PROPERTY DAMAGE (Per accident) \$
	DED	RETENTION \$					\$
	<b>WORKERS COMPENSATION AND EMPLOYERS' LIABILITY</b>						\$
	ANY PROPRIETOR/PARTNER/EXECUTIVE OFFICER/MEMBER EXCLUDED? (Mandatory in NH)	<input type="checkbox"/> Y <input checked="" type="checkbox"/> N	N/A				WC STATUTORY LIMITS
	If yes, describe under DESCRIPTION OF OPERATIONS below						OTHER
							E.L. EACH ACCIDENT \$
							E.L. DISEASE - EA EMPLOYEE \$
							E.L. DISEASE - POLICY LIMIT \$

DESCRIPTION OF OPERATIONS / LOCATIONS / VEHICLES (Attach ACORD 101, Additional Remarks Schedule, if more space is required)

Endorsement - (IF APPLICABLE, WILL BE DELIVERED WITH POLICY).  
 CANCELLATION 10 DAY NOTICE FOR NON PAYMENT, 30 DAYS ALL OTHERS

This certificate supersedes any previously issued certificate.

**CERTIFICATE HOLDER**

**CANCELLATION**

Bahman Shababi DBA AMA Glass  
 PO Box 99343  
 Emeryville, CA 94662

SHOULD ANY OF THE ABOVE DESCRIBED POLICIES BE CANCELLED BEFORE THE EXPIRATION DATE THEREOF, NOTICE WILL BE DELIVERED IN ACCORDANCE WITH THE POLICY PROVISIONS.

AUTHORIZED REPRESENTATIVE



# Your Contractors License Bond Verification Card

Contractors License Bond Verification Card

Contractors License Bond Verification Card

A M A GLASS

LICENSE NUMBER: 1011233  
BOND NUMBER: 04-WB082766  
SURETY COMPANY: WESCO INSURANCE COMPANY

EXP: 1/20/2021

This card is not proof of current bond status. For current status of bond and license shown, please contact the licensing board.

California Contractor State License Board  
www.cslb.ca.gov or 800.321.CSLB

Questions?  
Please contact your agent.

Always Sierra Ins Brokerage Inc  
916-476-3663  
2338 Gold River Rd Ste B  
Rancho Cordova CA 95670

## Instructions:

1. **Print** this page.
2. **Cut** along the dashed line.
3. **Fold** your card in half.
4. **Laminate**.

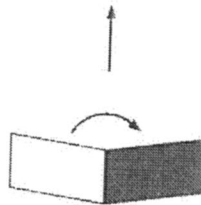

## Additional Cards for Your Convenience

Contractors License Bond Verification Card

Contractors License Bond Verification Card

A M A GLASS

LICENSE NUMBER: 1011233  
BOND NUMBER: 04-WB082766  
SURETY COMPANY: WESCO INSURANCE COMPANY

EXP: 1/20/2021

This card is not proof of current bond status. For current status of bond and license shown, please contact the licensing board.

California Contractor State License Board  
www.cslb.ca.gov or 800.321.CSLB

Questions?  
Please contact your agent.

Always Sierra Ins Brokerage Inc  
916-476-3663  
2338 Gold River Rd Ste B  
Rancho Cordova CA 95670

Contractors License Bond Verification Card

Contractors License Bond Verification Card

A M A GLASS

LICENSE NUMBER: 1011233  
BOND NUMBER: 04-WB082766  
SURETY COMPANY: WESCO INSURANCE COMPANY

EXP: 1/20/2021

This card is not proof of current bond status. For current status of bond and license shown, please contact the licensing board.

California Contractor State License Board  
www.cslb.ca.gov or 800.321.CSLB

Questions?  
Please contact your agent.

Always Sierra Ins Brokerage Inc  
916-476-3663  
2338 Gold River Rd Ste B  
Rancho Cordova CA 95670



Date: 6/24/2020



COMMERCIAL & RESIDENTIAL

*Estimate*

3080 Broadway  
Oakland CA 94611  
Lic#1011233  
Bahman Shababi

American Indian Model School  
Job Address: 171 12th ST  
Oakland Ca 9460

**ATTN: Tiffany Tung**

We propose to provide the following to install.

1) To remove 4 PCS existing single pane Fix window 1/4" glass the storefront system frame the building in First / Second /Third floor Classroom the Building

2) To install 4 PCS Dark Bronze Retro -Fit frame Double pane glass. Each window has three panels One on TOP fix window and Two BOT panel windows Awning Tempered glass with opener included screens and film all the windows .

Some of the wall on Classrooms is in the middle of the big windows. We aren't able to replace it ,not including in Estimate. Each windows for to replace will be \$3240.00

We will provide Certificate of liability Insurance and Bond

Material , Labor ,Tax

Total : \$ 89850.00

(Included Material, Labor,Tax

Quotation is valid for 30 days.

Thank you for giving us the opportunity to bid on your project.if this Quote meets with your approval please sign and return.

Tiffany Tung

: \_\_\_\_\_

Phone (510) 453-7030

Fax: (877) 666-5095

E-mail: amaglassco@gmail.com



DIFFERENT GROUP GLASS  
 Berkeley, CA  
 (510) 560-9636  
[contact@differentgroups.com](mailto:contact@differentgroups.com)  
[www.differentgroups.com](http://www.differentgroups.com)

## DIFFERENT GROUP GLASS

**Proposal**

DATE: 06/28/2020

CUSTOMER: Tiffany Tung  
 Aims

Tel: O: (510) 893-8701

C: (510) 912-4045

E-Mail: [tiffany.tung@aimsk12.org](mailto:tiffany.tung@aimsk12.org)

WORKSITE ADDRESS: American Indian Model schools  
 171 12th street, Oakland, CA 94607

**QUOTE**

WINDOW TYPE	SIZE	THICKNESS	NOTES	UNIT price	QTY	TTL PRICE
Double pane modern Aluminum Awning window <i>Safety tempered</i>	47 X 25	1 inch O/A Glass	The top 25 inches of the existing glass will be transformed into an awning window to allow perfect airflow into the room. The new window will open towards the outside and will include a window screen.	1475	34	50150.00
Replacement glass with bronze film <i>Safety tempered</i>	47 X 50	1/4	The lower ~50 inches of the existing glass will be replaced by a one-piece of 1/4 thick <i>Safety tempered</i> glass with sun shield bronze film to match the existing panels.	1250	34	42500.00
Bronze Aluminum separation bar	47	/	A bronze aluminum separation bar will be placed to separate the new awning window from the new tempered pane of glass and make all future repairs easy and accessible.	175	34	5950.00
				<b>TOTAL</b>	<b>/</b>	<b>\$98600.00</b>

**ALL PRICES INCLUDE LABOR AND MATERIAL.**

Please let us know if you'd like us to make any adjustments.

**DIFFERENT GROUP GLASS**

Berkeley, CA

(510) 560-9636

[contact@differentgroups.com](mailto:contact@differentgroups.com)

[www.differentgroups.com](http://www.differentgroups.com)

**ESTIMATED COMPLETION DATE: July 30th, 2020**

**ON-SITE WORK ESTIMATED DURATION: 9 days**

**ESTIMATED SIZE OF THE TEAM THAT WILL OCCUPY THE WORKSITE  
DURING WORK HOURS FOR THE DURATION ABOVE: 7 technicians  
and 1 supervisor.**

Please let us know if you'd like us to make any adjustments.

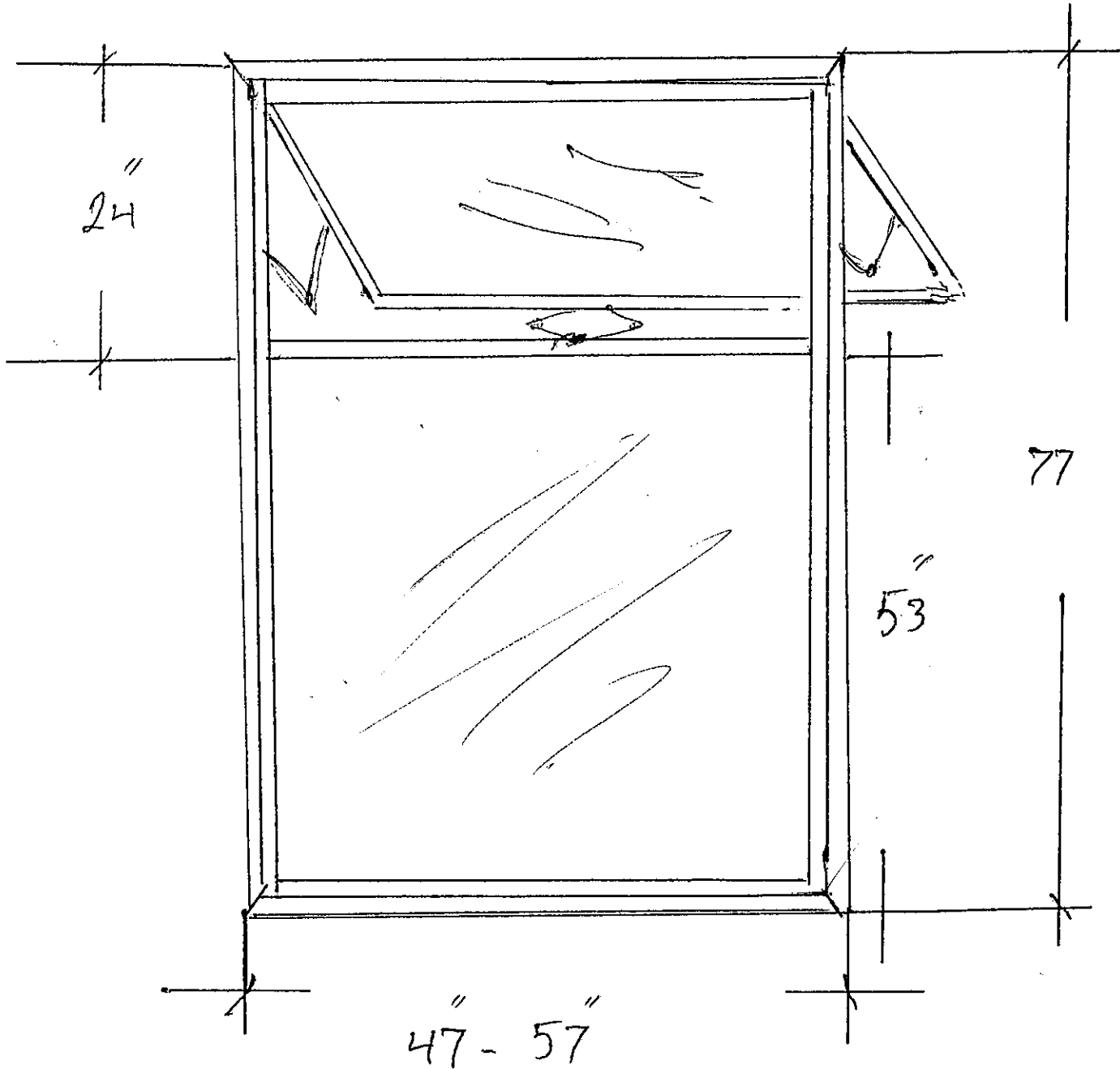



## AIMS Board Meeting Item Cover Letter

Item:

Presented By:

Staff Recommendation:

Committee Approval:

Total Associated Cost:

Included in Budget?

Over or Under Budget?

Amount Over/Under Budget?

Included in LCAP?

Which LCAP?

## Coversheet

### Learning Continuity and Attendance Plan (LCAP) for AIPCS, AIPCS II and AIPHS

**Section:** III. Action Items  
**Item:** F. Learning Continuity and Attendance Plan (LCAP) for AIPCS, AIPCS II  
and AIPHS  
**Purpose:** Vote  
**Submitted by:**  
**Related Material:** American Indian Public High School Learning Continuity Plan.docx  
LCaAP Cover Letter.pdf  
AIPCS II - LC and Attendance Plan.docx  
AIPCS - LC and Attendance Plan.docx

California Department of Education, July 2020

## Learning Continuity and Attendance Plan Template (2020–21)

The instructions for completing the Learning Continuity and Attendance Plan is available at <https://www.cde.ca.gov/re/lc/documents/lrngcntntyatndncpln-instructions.docx>.

Local Educational Agency (LEA) Name	Contact Name and Title	Email and Phone
American Indian Public High School	Maurice Williams, Head of School	maurice.williams@aimsk12.org

### General Information

[A description of the impact the COVID-19 pandemic has had on the LEA and its community.]

The unprecedented COVID-19 pandemic has impacted our school community and dramatically affected and altered the lives of our students, families and staff. The closure of schools have negatively impacted the emotional, physical, social and educational environment. Closure of our schools has resulted in families being challenged in access to basic services, and conducive school environments that are not meeting the standards that allow students to learn effectively. Families, students and staff have all been affected with higher levels of anxiety and stress due to lack of resources, inability to support their children academically during distance learning, and financial hardships due to massive layoffs due to the pandemic.

Staff and faculty are now faced with surmountable challenges however we continue to ensure in spite of these unpredictable changes that our students are supported instructional continuity in a remote learning environment by focusing coursework on new learning, as opposed to review and reinforcement. Providing and leveraging the technology needed and resources available and support resources. This includes providing a variety of support resources in order for instruction and material to be available to all students, including our special education population, students with 504 plans, English Language Learners, students with social emotional needs, and students who are in need of technology access.

We empathize with our school community who have been impacted by COVID-19 pandemic and want to reiterate that the safety of the AIPHS community is our No. 1 priority. AIPHS continues to be committed to providing high-quality learning experiences for all of our students during school closures. The plan provides opportunities for students to acquire the knowledge and skills needed to succeed at the next grade level/subsequent course, while building in flexibility to accommodate the unique circumstances of every student.

Comment [1]: I added a few more paragraphs to general information, please review if any changes need to be made.

### Stakeholder Engagement

[A description of the efforts made to solicit stakeholder feedback.]

The LEA held several parent, teacher, and student engagements to inform them of COVID-19 related school reopenings, new programming for the 20-21 academic school year, and efforts made by the LEA to keep students safe. Surveys were sent to teachers inquiring of their



willingness to teach virtually from their classrooms in the fall. Additionally, parents were sent surveys regarding their preferences to hold in-person learning for their students and their accessibility to technology.

[A description of the options provided for remote participation in public meetings and public hearings.]

Participants were provided the opportunity to participate in COVID-19 related school reopening Zoom meetings via computer or by phone. Cantonese and Spanish translators also formed breakout rooms to translate all presented materials into their designated language.

[A summary of the feedback provided by specific stakeholder groups.]

Based upon stakeholder family feedback, most families were comfortable with sending their students to school, provided that the LEA provided the appropriate PPE for students and maintained social distancing that was consistent with State and County guidance. Students and families both supported AIMS HS’s Hybrid learning model, in which 10-12 students per first period class were assigned to attend school on a 3-day rotating basis. It goes without saying that students are overwhelmingly in favor of returning to school at the earliest possible convenience.

[A description of the aspects of the Learning Continuity and Attendance Plan that were influenced by specific stakeholder input.]

Parents that requested that their child “opt-out” of in-person instruction were provided information on how to do so, provided that the student was made fully aware of their responsibility to attend all courses virtually and complete all assignments as normal. Parents also requested the possibility to keep their reusable masks, rather than have them washed at the school site. Lastly, some parents requested preferences to use their own N95 or KN95 masks to wear, rather than the school’s issued masks.

## Continuity of Learning

### In-Person Instructional Offerings

[A description of the actions the LEA will take to offer classroom-based instruction whenever possible, particularly for students who have experienced significant learning loss due to school closures in the 2019–2020 school year or are at a greater risk of experiencing learning loss due to future school closures.]

Under current county and state guidelines, the LEA is prohibited from offering in-person classroom-based instruction until Alameda county reaches a threshold of low COVID-19 cases. For these reasons, the LEA has prohibited in person instruction on campus for the first Semester. The determination to hold in person classroom instruction may change, pending an update in state, county, and charter authorizer guidance. Nevertheless, the LEA has purchased reusable face masks and face shields, plexiglass barriers, increased custodial support, no-touch temperature check kiosks, social distancing signage, to prepare for in-person learning.

### Actions Related to In-Person Instructional Offerings [additional rows and actions may be added as necessary]

Description	Total Funds	Contributing
-------------	-------------	--------------

Student Chromebooks, computer refresh, internet hotspot purchases, and ongoing internet services in 2020-21 school year	\$15,000	[Y/N]
Classroom technology upgrades - TV, TV Cart, ChromeCast, Projectors	\$25,000	[Y/N]
Teachers and substitute teachers	\$1,700,000	[Y/N]
Academic Deans/Instructional Coaches	\$120,000	[Y/N]
Professional development for teachers, lead teacher, classified support staff, and administrators	\$30,000	[Y/N]
Services for English learners ELD support and development	\$175,000	[Y/N]
Stakeholder engagement - Resources assigned for parent engagement distance meetings and webinar workshops - PowerSchool - Student information system and ParentSquare and Ringcentral	\$65,000	[Y/N]
Schoology, Illuminate, ALEKS, Quill, Scholastic Reading Inventory, GoGuardian, - Educational Platforms	\$20,000	[Y/N]
Intervention Aides, attendance clerks, support staff	\$690,000	[Y/N]
The school has prepared for possible in-person learning by purchasing cleaning supplies, and protection materials (including plexiglass, and PPE).	\$100,000	[Y/N]

## Distance Learning Program

### Continuity of Instruction

[A description of how the LEA will provide continuity of instruction during the school year to ensure pupils have access to a full curriculum of substantially similar quality regardless of the method of delivery, including the LEA’s plan for curriculum and instructional resources that will ensure instructional continuity for pupils if a transition between in-person instruction and distance learning is necessary.]

Courses offered with distance learning are identical to those offered with in-person instruction at AIMS High School. Teachers submit a course syllabus and pacing guide for each course as commitment to adherence to the course frameworks and state standards. Weekly lesson plans are submitted by each teacher, and these are compared for congruence to the pacing guides. AP courses are available to all students and the curriculum taught follows the AP College Board course and exam descriptions. The length of each class and the length of the school day are the same with distance learning as with in-person instruction, with the same number of instructional minutes provided to students.

### Access to Devices and Connectivity

[A description of how the LEA will ensure access to devices and connectivity for all pupils to support distance learning.]

The LEA has selected two online platforms for distance learning, Schoology and Zoom, with Schoology the primary platform and Zoom the secondary platform. Teachers have been trained in the use of both. All students have been provided with a Chromebook, and where needed, hotspots have been provided to students. GoGuardian has been installed on Chromebooks which assures teachers that students remain on task without access to other online sites. Students are required to have their cameras on so that teachers can be assured they are involved

in the lessons. During certain times in the lessons, students are assigned to breakout rooms for discussion and/or collaboration, for which teachers assign and monitor activities.

## Pupil Participation and Progress

[A description of how the LEA will assess pupil progress through live contacts and synchronous instructional minutes, and a description of how the LEA will measure participation and time value of pupil work.]

Students will receive an average of 20-22 hours of synchronous instructional minutes per week. Assessment of pupil progress can be conducted in a number of ways at AIMS. All teachers submit weekly lesson plans and have assessment grades uploaded to PowerSchool weekly, as a means to ensuring that students' learning progress is taught and documented. Lesson plans are monitored and feedback and suggestions are given on a regular, on-going basis to teachers, with particular focus on students' participation and engagement in class activities through the incorporation of various methods and strategies of differentiation to support student learning. Progress reports are also sent out every three weeks, with teachers' comments and suggestions listed for those students who need support and assistance with their learning. Report cards are sent home every nine weeks. There are also two scheduled days during the school year, one per semester, where school is closed for students, so that teacher/ parent conferences can be held. Tutoring is provided two to three times a week for students who are having difficulties in class, and they are also expected to attend weekly Academic Saturday School until their grades improve. All staff hold office hours and are available to meet with parents or to conduct a phone conference in order to answer questions about their students' progress. Students' grades are uploaded into Schoology and synched to PowerSchool weekly.. Parents are also able to communicate with staff through the use of ParentSquare to inquire about their student's academic progress or when they have other concerns. All class assignments are listed on the Schoology online learning platform.

## Distance Learning Professional Development

[A description of the professional development and resources that will be provided to staff to support the distance learning program, including technological support.]

When the Distance Learning took place in March, 2019, all staff immediately took part in training on our online platform, Schoology. When it was mandated that distance learning was going to take place again during the Fall Semester, AIMS also assembled training in these online learning programs in addition to Schoology training to assist with the distance learning program to support teachers with their teaching: ALEKS (math), Quill (ELA/ELD, History), Scholastic Reading Inventory (SRI), Learning Ally (ELA/ELD). All staff also received training for the programs used in General Education courses: Turnitin, Go Guardian, PowerSchool, Mandated Reporter Training, and a Socio and Emotional presentation by the district Health & Wellness Counselor. At AIMS, we have an onsite Technical Support Provider to assist with any tech needs, in addition to staff communication using the Slack application on cell phones and laptops.

## Staff Roles and Responsibilities

[A description of the new roles and responsibilities of affected staff as a result of COVID-19.]

During virtual distance learning, clerical staff roles have shifted to provide more one-on-one technical support to our students, teachers, families. Timely responses to emails, particularly in tech support inquiries are critical. To avoid a bombardment of our school’s email account (particularly due to a flurry of random email requests), the LEA created separate email accounts for attendance, transcripts, and work permits, while leaving the high school’s main email account to focus on technical support and general inquiries. The LEA expanded its SLACK communication platform internally in order to allow instructors to communicate academic issues or concerns (internet connectivity, unresponsive students, help desk questions, etc.) in real time.

## Supports for Pupils with Unique Needs

[A description of the additional supports the LEA will provide during distance learning to assist pupils with unique needs, including English learners, pupils with exceptional needs served across the full continuum of placements, pupils in foster care, and pupils who are experiencing homelessness.]

AIMS High School currently has a Resource Program with a full time Resource Specialist and Instructional Aide. All students with IEPs will receive the push-in and pull-out service minutes in their plans as written. Both push-in and pull-out services are conducted virtually, with pull out times built in to student schedules. After school tutorial sessions are available for students needing additional support with online learning. Support services such as Speech Therapy are also being provided virtually. General education teachers have 1:1 IEP accommodations reviews with RSP, and the RSP is available for consultation and collaboration during teacher prep periods.

AIMS HS also has a full-time ELD teacher and Instructional Aide, who are fully trained to teach the ELD curriculum, and to support those students from the emerging to expanding levels, and beyond. The goal is to have all students proficient in English so that they can keep pace with their peers. Additional support services are given to those students who are ready to exit the ELD program, especially with their writing, through their enrollment in the ELD Language Lab class. All ELD students are also using the resources provided through such programs as Rosetta Stone (speaking, listening, comprehension), Learning Ally (reading, listening), and Quill (writing). When there is a need for translation services at any of the sites, there are a number of staff members who may assist with the translation for the over eleven different languages which are spoken in the District.

A third non-departmental Instructional Aide will be on-hand to help provide general support to students and others as needed.

A lunch program is provided for any students who qualify. During distance learning, students or families may come to the middle school campus to pick up lunches during the week.

## Actions Related to the Distance Learning Program [additional rows and actions may be added as necessary]

Description	Total Funds	Contributing
Student Chromebooks, computer refresh, internet hotspot purchases, and ongoing internet services in 2020-21 school year	\$15,000	[Y/N]
Classroom technology upgrades - TV, TV Cart, ChromeCast, Projectors, Webcameras, Wireless Headsets	\$25,000	[Y/N]
Teachers and substitute teachers	\$1,700,000	[Y/N]
Academic Deans/Instructional Coaches	\$120,000	[Y/N]

Professional development for teachers, lead teacher, classified support staff, and administrators	\$20,000	[Y/N]
Services for English learners ELD support and development	\$175,000	[Y/N]
Stakeholder engagement - Resources assigned for parent engagement distance meetings and webinar workshops - PowerSchool - Student information system and ParentSquare and Ringcentral	\$65,000	[Y/N]
Schoology, Illuminate, ALEKS, Quill, Standards Plus, Scholastic Reading Inventory, GoGuardian - Educational Platforms	\$20,000	[Y/N]
Instructional Aides	\$220,000	[Y/N]
Art Supplies	\$12,000	[Y/N]
Attendance clerks, support staff	\$470,000	[Y/N]

## Pupil Learning Loss

[A description of how the LEA will address pupil learning loss that results from COVID-19 during the 2019–2020 and 2020–21 school years, including how the LEA will assess pupils to measure learning status, particularly in the areas of English language arts, English language development, and mathematics.]

During the 2019-2020 academic school year, the LEA also maintained at least 4-5 hours of synchronistic academic instruction per day and will provide at least 5-6 hours of synchronistic instruction for students daily for the 2020-21 academic school year. The LEA will use ALEKS to diagnose student math performance and will use CAASPP math interims for all 9th, 10th, and 11th graders. The LEA will also use CAASPP ELA interims for all 9th, 10th, and 11th graders. The LEA will also use Scholastic Reading Inventory (SRI) to track student Lexile Reading Scores, and will assign Quill writing for all ELA classes as writing benchmarks.

### Pupil Learning Loss Strategies

[A description of the actions and strategies the LEA will use to address learning loss and accelerate learning progress for pupils, as needed, including how these strategies differ for pupils who are English learners; low-income; foster youth; pupils with exceptional needs; and pupils experiencing homelessness.]

The LEA will develop and implement a benchmark assessment calendar: CAASPP (Math / ELA) Interims - (Once per Semester); SRI and Quill Benchmarks (Once per quarter), ALEKS (twice per year - beginning and end of school year.) Accelerated Math students will be able to work independently on ALEKS and be allowed to take higher level math courses on the ALEKS math platform. Students with low math performances will have the opportunity to work on prerequisite math ALEKS as RTI, which will help improve students ability to complete higher level math beyond their math frustration levels. Students may be assigned Saturday School or tutoring as a result of consistently low benchmark scores.

### Effectiveness of Implemented Pupil Learning Loss Strategies

[A description of how the effectiveness of the services or supports provided to address learning loss will be measured.]

The LEA will establish virtual data walls for each student and grade level to measure and monitor their progress.

### **Actions to Address Pupil Learning Loss [additional rows and actions may be added as necessary]**

Description	Total Funds	Contributing
Academic Saturday School	\$20,000	[Y/N]

## **Mental Health and Social and Emotional Well-Being**

[A description of how the LEA will monitor and support mental health and social and emotional well-being of pupils and staff during the school year, including the professional development and resources that will be provided to pupils and staff to address trauma and other impacts of COVID-19 on the school community.]

When classroom teachers, support staff or parents make referrals of students, reporting urgent or lower-tiered behaviors indicating mental health concerns, the Head of School and/or Dean of Students report directly to a state-licensed MFT counselor within 30 – 60 minutes. A referred student is then placed on a counselor’s client list and flagged for immediate contact. A clinical assessment is made, and a treatment plan is established, including a behavior modification plan, and this plan is shared with consenting parents and related school staff. If indicated, students begin meeting with a counselor and are in session with the counselor for 45 minutes per week. Currently, the counselor meets with an ongoing roster of approximately 70 active student clients.

Staff Professional Development modules are presented to staff regarding a wide range of mental health issues. Staff is also trained in ways to spot mental health concerns and make effective and timely student referrals to counselors.

Current state-of-the-art mental health strategies applying to the social and emotional learning in the context of Covid-19 are taught and provided to staff and students on a quarterly basis. These strategies are resourced from the CDC, State of California Mental Health Agency, and the UC Berkeley Greater Good Science Center. The monitoring of student mental health and social emotional well-being will include regular collection of student emotional engagement data via regular surveys by staff of student engagement and participation. Regular emotional engagement surveys will help staff assess a student’s involvement in and enthusiasm for school as a whole as well as their emotional connectedness to others during distance learning.

Indicators monitored by staff to serve as emotional engagement metrics will include:

- Level of engagement with support staff/groups
- Participation in activities
- Participation in co-curricular and extra-curricular activities

## **Pupil and Family Engagement and Outreach**

[A description of pupil engagement and outreach, including the procedures for tiered reengagement strategies for pupils who are absent from distance learning and how the LEA will provide outreach to pupils and their parents or guardians, including in languages other than English, when pupils are not meeting compulsory education requirements, or if the LEA determines the pupil is not engaging in instruction and is at risk of learning loss.]



Students that are not present in class receive calls and notices to families for failing to attend school. Students that are absent from school are required to attend the next available Saturday School. Students with 3 unexcused absences will receive a Truancy letter from the school and will be required to respond within 10 days of receipt of the notice to attend a SART meeting with an administrator, and the affected classes to discuss possible methods to increase student attendance. Students that fail to meet these requirements after three truancy notices and meetings may be referred to a SARB hearing or the District Attorney's office for Truancy. The LEA utilizes Cantonese, Spanish, Arabic, and Amharic translators to help service the needs of our students and multicultural demographic populations.

Comprehensive family engagement support services are being provided by the Parent Coordinator for all campuses across the district. Support is given to individual parents and families through email, phone, and virtual meetings. Translation and bilingual support is being provided to families in student success meetings between families and teachers to discuss and navigate transitions to online learning and best practices. Additionally, these meetings have been used to provide integral interventions for specific students who have multi-faceted needs for differentiation. The Parent Coordinator has been serving as a liaison between administrative staff across the district and families, fielding parent concerns, directing parents to appropriate resources needed, assisting with technology concerns, and communicating with families and administrative staff on an ongoing basis.

The Parent Coordinator has been instrumental in assisting in providing supplemental comprehensive resources for families, and interfacing with community partnerships to bring programming to families. This department is also working in partnership with Alameda county to provide a virtual census informational meeting. In addition, through family engagement services AIMS is providing multiple resources for family engagement, parent education, virtual parent classes, support, and virtual family events.

One of these events planned is a mother/daughter mentoring brunch. There will be a preteen cohort and a teen cohort. Through this program, parents will gain key skills to maintain open and positive communication with their children, explore a key topic each session, and have breakout sessions to build on skills learned. These communication sessions will be leveled to topics appropriate to the developmental stages of the cohorts, and will include mentoring for families and education. This department has also partnered with a community based organization to provide a series of virtual parenting webinars that has been opened to parents across the district. Additional resources and support are being provided through virtual office hours, check-ins, emails, and parent/family meetings.

## School Nutrition

[A description of how the LEA will provide nutritionally adequate meals for all pupils, including those students who are eligible for free or reduced-price meals, when pupils are participating in both in-person instruction and distance learning, as applicable.]

AIMS nutrition services will continue implementing procedures developed during the spring school closures to ensure safe and effective meal services. This include use of a drive-thru process for families that ensures 6-10 feet of social distancing for staff and community members, use of appropriate personal protective equipment (PPE) by all staff, clear signage at all distribution points to reinforce social distancing practices, use of masks for community and staff required per state and county health guidelines.

All students in the district have access to nutritious meals. We are able to provide our students with access to a variety of affordable and appealing foods that meet the health and nutrition needs of students. All meals, foods and beverages sold or served at school meet state and federal requirements based on the USDA Dietary Guidelines. All meals, foods and beverages are prepared and served by qualified child nutrition professionals to ensure all students are provided access to healthy meals. All meals are provided throughout the term of distance learning. Families are given five day meal kits to ensure accessibility and all CDC requirements are met to ensure families are distributed meals safely. Our district has provided families with the convenience of applying for lunch applications online and in person. All families that qualify for free or reduced meals are informed and encouraged to pick up meals. All families that qualify for paid meals are encouraged to participate in the NSLP (National School Lunch Program), payments are set at a minimum for paid families to ensure meals are affordable for families that do not qualify for free or reduced priced meals. During distance learning all meals are distributed once a week and families are given five day meal kits. All meal kits cover the components that ensure healthy meals per serving. During in person instruction, meals will be distributed in person to all students. All food handlers and staff supporting are qualified and certificated and approved by Alameda County Environmental Health to distribute food during COVID-19. All staff have been trained and will follow CDC guidelines to ensure proper food handling and distribution.

Section	Description	Total Funds	Contributing
Actions Related to In-Person Instructional Offerings	Hire a School Nurse and Design a state-of the art Nurse’s office	\$110,000	[Y/N]
Actions Related to In-Person Instructional Offerings	Washer and Dryer Piping, Electrical, and Installation	\$15,000	[Y/N]

## Increased or Improved Services for Foster Youth, English Learners, and Low-Income Students

Percentage to Increase or Improve Services	Increased Apportionment Based on the Enrollment of Foster Youth, English Learners, and Low-Income students
[Insert percentage here]%	[Insert dollar amount here]

### Required Descriptions

[For the actions being provided to an entire school, or across the entire school district or county office of education (COE), an explanation of (1) how the needs of foster youth, English learners, and low-income students were considered first, and (2) how these actions are effective in meeting the needs of these students.]

[Provide description here]

[A description of how services for foster youth, English learners, and low-income students are being increased or improved by the percentage required.]



Services to these sub-groups have been increased especially for English Learners who are easily identified. Low-income students have been a part of our school (70+% Title 1), so including their concerns are typical for all planning and budgeting. Because we are doing as much or more follow-up since students can more easily drop off of one class or another, there are more opportunities to find out more about a student's situation. Clerical staff are making at least as many phone calls. Teachers are making more calls to students and writing more emails to students and families. The entire educational program has been receiving more scrutiny and intentional decision making since last Fall (2019), renewed in February and March, and then into the beginning of this academic year (2020-2021).



## AIMS Board Meeting Item Cover Letter

Item:

Presented By:

Staff Recommendation:

Committee Approval:

Total Associated Cost:

Included in Budget?

Over or Under Budget?

Amount Over/Under Budget?

Included in LCAP?

Which LCAP?

California Department of Education, July 2020

# Learning Continuity and Attendance Plan Template (2020–21)

The instructions for completing the Learning Continuity and Attendance Plan is available at <https://www.cde.ca.gov/re/lc/documents/lrngcntntyatndncpln-instructions.docx>.

Local Educational Agency (LEA) Name	Contact Name and Title	Email and Phone
American Indian Public Charter School II	Christopher Ahmad, Head of School Peter Holmquist, Head of School	<a href="mailto:christopher.ahmad@aimsk12.org">christopher.ahmad@aimsk12.org</a> , 510-893-8701 <a href="mailto:peter.holmquist@aimsk12.org">peter.holmquist@aimsk12.org</a> , 510-893-8701

## General Information

[A description of the impact the COVID-19 pandemic has had on the LEA and its community.]

The unprecedented COVID-19 pandemic has impacted our school community and dramatically affected and altered the lives of our students, families and staff. The closure of schools have negatively impacted the emotional, physical, social and educational environment. Closure of our schools has resulted in families being challenged in access to basic services, and conducive school environments that are not meeting the standards that allow students to learn effectively. Families, students and staff have all been affected with higher levels of anxiety and stress due to lack of resources, inability to support their children academically during distance learning, and financial hardships due to massive layoffs due to the pandemic.

Staff and faculty are now faced with surmountable challenges however we continue to ensure in spite of these unpredictable changes that our students are supported instructional continuity in a remote learning environment by focusing coursework on new learning, as opposed to review and reinforcement. Providing and leveraging the technology needed and resources available and support resources. This includes providing a variety of support resources in order for instruction and material to be available to all students, including our special education population, students with 504 plans, English Language Learners, students with social emotional needs, and students who are in need of technology access.

We empathize with our school community who have been impacted by COVID-19 pandemic and want to reiterate that the safety of the AIPCS II community is our No. 1 priority. AIPCS II continues to be committed to providing high-quality learning experiences for all of our students during school closures. The plan provides opportunities for students to acquire the knowledge and skills needed to succeed at the next grade level/subsequent course, while building in flexibility to accommodate the unique circumstances of every student.

Comment [1]: I added a few more paragraphs to general information, please review if changes need to be made.

# Stakeholder Engagement

[A description of the efforts made to solicit stakeholder feedback.]

**Elementary K-5 Response:** In order to get feedback from our various stakeholders, we held meetings with teachers, staff, and students via Zoom to see what would be beneficial for them. We held an initial meeting where we discussed how we will be following state and county health guidelines along with our plans for reopening. Parents were given feedback forms and were able to ask questions and get their answers that day as we set aside a few hours. We then allowed students to opt for virtual learning for their child for the time being. We held a second informational meeting with our stakeholders discussing distance learning, health guidelines, and plans to return. Students, Staff, and Parents were all given time to ask and answer questions via Google Form. Feedback was taken into consideration and adjustments were made to suit the needs of many.

**Middle School (6-8) Response:** Teachers have been involved in the development of the plan for distance learning since before March. Their processing of the details, experience of the online platforms, and the foibles of each service featured in the planning of the potential on-site learning options. Without inundating teachers over their summer break, emails and other meeting offerings were shared that gave opportunities to hear updates on plans being made for “re-opening” in the Fall of 2020.

Parents and students were some of the first people beyond staff, who were informed about the developing plans for safety as we considered how to return to on-site classrooms. Taking teacher input, as well as the strong instructions from county and state officials, plans were crafted through July, 2020. These were shared with all parents over the summer as they were developing. These were communicated through multiple videos, zoom meetings, ParentSquares, and direct emails. The two most recent meetings intended to share as widely as possible included translations into Chinese and Spanish and over 90 minutes of question and answer time. These question and answer sessions were then incorporated into the ongoing message to respond to parent and student concerns.

A new email address was set up in April to serve as a clearinghouse for information about the Middle School. Staff received training on how to address the needs or directed to whom the questions should go. Appointments were scheduled for resource drop off and pick-up through that email address.

[A description of the options provided for remote participation in public meetings and public hearings.]

**Elementary K-5 Response:** AIMS holds board meetings on the third Tuesday of each month. This is a public meeting that families and other stakeholders can attend. The agendas are posted, Zoom links are given out, and we allow public comments digitally.

**Middle School Response:** All Board meetings, committee meetings while also posted onsite, were posted online on the district website, with video conferencing, or zoom links. Parent meetings were posted through ParentSquare and reached 620 people’s devices. Translation of announcements and meeting scripts were translated. Meeting links were translated.

[A summary of the feedback provided by specific stakeholder groups.]

**Elementary K-5 Response:**

Parents: Please allow children the option to do virtual learning for the whole year. (We gave this option and over 50 parents confirmed)

Students: Please allow us to take breaks from the computer screens. (Breaks are given every 30-60 mins depending on grade level. They also have 1 hour of physical activity and also an hour lunch break.

Staff: Can we have an option to go back and teach from our classroom. (We gave this option to all teachers and we will be opening up classrooms for teachers to utilize during virtual learning starting September 9th.)

Middle School Response: Parents appreciated the opportunities to hear administrators and the district respond to their concerns. Main items or topics of concern included: 1) the desire to keep a student home rather than send them to school when that became a possibility, 2) a concern for some aspect of technology (ease of use, access, availability, wi-fi), or 3) support for struggling students in this online classroom time.

[A description of the aspects of the Learning Continuity and Attendance Plan that were influenced by specific stakeholder input.]

Elementary K-5 Response: The first step was to make sure every student had a laptop. We had 3 full weeks of passing out laptops to families before school started. We then made each teacher have a parent meeting before the first day of school where they were able to show parents how to login, which sites to use, and how to use a computer. The teachers spent the first few days of instructions working with parents and teaching them how to use the programs alongside their children.

Middle School Response: The District legal team is working to complete a permission form to allow a student to “opt-out” of on-site classrooms. (State laws obviously impact the form’s development as well.) Teacher concerns for a safe work environment continue to clarify the need for front and back office practices in cleanliness and safety. Parent concerns for (#1 above) keeping students home was addressed repeatedly orally, and in messaging to communicate the process and confirmation of the parent choice when it became available. Parent concerns for one aspect of technology (#2 above) was addressed by providing digital resources for students and devices with which to reach them. Another aspect of technology concern was the provision for parent links - access - to their student’s information. In addition, our school continues to have information sessions and tutorials to help parents (and students) with logging into the online platform (LMS) that serves as the focus of much of the handing in and passing out of digital resources and assignments. The district continues to support individual families with referrals to low cost internet plans and hot spots as main strategies to the problem of internet access. Support for students who do not seem to be flourishing in this digital environment is being addressed by tutoring after class hours, Saturday school support, and other Teacher Office Hours. An Instructional Aide has been hired to help in various classes. English language learners and Special Education students also receive dedicated staff support.

## Continuity of Learning

### In-Person Instructional Offerings

[A description of the actions the LEA will take to offer classroom-based instruction whenever possible, particularly for students who have experienced significant learning loss due to school closures in the 2019–2020 school year or are at a greater risk of experiencing learning loss due to future school closures.]

**Elementary K-5 Response:** As of right now, we are offering virtual learning until the end of 2020. After that, we will reconsider going back in for in-person instruction based on the recommendations of the county and state. We will have virtual learning pods on site for those students who do not have an adult to watch over them. We will allow students to work from our campus and do their virtual learning while an adult staff member supervises them. To combat loss of learning, we are offering 1 hour of additional tutoring after school each day from the classroom teacher. We have also acquired new independent learning programs online that work at a child’s academic level with a progression system built in.

**Middle School Response:** We prepared two scenarios for returning to school this Fall 2020. The First Scenario is for on-site instruction: “Hybrid” schedules will feature in-class & online instruction rotation for three student groups from each class. A,B, and C groups will rotate through the school, one day in school, two days at home. This schedule will repeat and have equitable instructional minutes on campus over three weeks. In this scenario Fridays will all be virtual.

Students will be grouped for scenario 1, into heterogeneous groupings across their grade level, preserving the previous year classes, and AIMS’ preference for “looping” classes. Teachers will be consulted in the exact mix of students to ensure maximum feasibility and minimize distraction. ELD and Resource staff schedules will also be take into consideration in group construction and schedules to maximize intervention efforts and resources.

Support for students who do not seem to be flourishing in this digital environment is being addressed by tutoring after class hours, Saturday school support, and other Teacher Office Hours. An Instructional Aide has been hired to help in class. Special Education students also receive dedicated staff support. English Language Learners receive specific instruction as well as supplemental supports from targeted software.

**Actions Related to In-Person Instructional Offerings [additional rows and actions may be added as necessary]**

Description	Total Funds	Contributing
Student Chromebooks, computer refresh, internet hotspot purchases, and ongoing internet services in 2020-21 school year	MS \$9216.41	[Y/N]
Classroom technology upgrades - TV Cart, Projectors, Projector brackets	MS \$1040.59 ES \$13376.63	
New computers for teachers and support staff	\$34,731.78	
Teachers and substitute teachers	MS \$703,839 EM 1,595,060.00	[Y/N]
Academic Deans/Instructional Coaches	(em \$127,991.57) (MS \$100,712)	
Professional development for teachers, lead teacher, classified support staff, and administrators (elementary \$15,000) (MS \$7000)	\$22,000	
Services for English learners ELD support and development (MS \$5162.15) (ES \$3000)	\$8162.15	

Stakeholder engagement - Resources assigned for parent engagement distance meetings and webinar workshops - PowerSchool - Student information system and ParentSquare and Ringcentral	\$17,000	
Schoology, Illuminate, ALEKS, Quill, Standards Plus, Scholastic Reading Inventory, GoGuardian - Educational Platforms	\$58,251	
Intervention Aides	\$190,059	
Attendance clerks, support staff	\$308,571.22	
ELD Teacher Salaries	\$ 87,990.24	[Y/N]
Intervention Staff Salaries (elementary school)	\$ 294,513.65	[Y/N]
The school has prepared for possible in-person learning by purchasing cleaning supplies, upgraded HVAC filters, and protection materials (including plexiglass, and PPE). Upgraded cleaning is essential for safety.	\$180,000	
BACR Staff Member x 4 to supervise students who don't have adult supervision at home	ASES	Y
Individual Learning programs that are self-paced: Quill, Learning Farm (elementary)	\$2,946.00	Y

## Distance Learning Program

### Continuity of Instruction

[A description of how the LEA will provide continuity of instruction during the school year to ensure pupils have access to a full curriculum of substantially similar quality regardless of the method of delivery, including the LEA's plan for curriculum and instructional resources that will ensure instructional continuity for pupils if a transition between in-person instruction and distance learning is necessary.]

Elementary K-5 Response: The elementary decided to make their virtual schedules replicate that of in-person instruction. We have the same instructional minutes. We transferred all of our textbook curricula over to digital platforms. Teachers and students have full access to every chapter and lesson digitally as they would if they were in class. We also have made sure that the same interventions take place. Students are receiving pull-out intervention services daily and we also trained teachers to use breakout rooms with aides for small group instruction.

Middle School Response:

#### **LMS - Schoology:**

- AIMS Middle School currently has Schoology as our Learning Management System that is utilized to continue instructions in remote as well as classroom settings.
- Various supporting tools/programs are integrated with Schoology to enable teachers & students to access as well as edit the documents etc.
- Students' & teachers' google drives are enabled on Schoology platforms. Middle School teachers received an extended Schoology training last year and there was additional training at the beginning of, and ongoing PD

- **Content Specific Digital Learning Resources suitable for Blended Learning**

- Illuminate
- Powerschool
- ALEKS (Math)
- McGrawHill (Science)
- Standards Plus (ELA)
- SRI (Reading)
- Quill (Writing)
- Rosetta Stone (World Language & ELD) during the 2020-21 school year.

## Access to Devices and Connectivity

[A description of how the LEA will ensure access to devices and connectivity for all pupils to support distance learning.]

Elementary K-5 Response: For 3 weeks, we had laptop pickup days. We passed out over 350 laptops to students. We also purchased over 100 new laptops to make us at a 1:1 student to laptop ratio. We also partnered with the Oakland Tech Exchange to provide internet access to families at a reduced cost. So far, we have over a 97% attendance rate and every student has a device, internet, and access to our programs

Middle School Response: The district and school have invited responses to multiple surveys in which families can mention or describe their need. Teachers have been alerted to watch and make provision to include students who seem to have connectivity issues. Distribution of resources takes place on a publicized day for grade levels to come in and check out a device. At that time passwords and login information has been given out. Families who miss the official day, or who have problems with their technology are invited to contact [middleschool@aimsk12.org](mailto:middleschool@aimsk12.org) to make an appointment, or get a response seeking more information before requiring replacement of the device. At this time around 300 devices have been distributed to the MS alone (252 over three days).

## Pupil Participation and Progress

[A description of how the LEA will assess pupil progress through live contacts and synchronous instructional minutes, and a description of how the LEA will measure participation and time value of pupil work.]

Elementary K-5 Response: Every morning, students are to login to Zoom which counts for attendance. The lessons will all be taught virtually for direct instruction and guided practice. Independent practice is away from the computers. Assessments are given weekly and benchmarks are given every six weeks. In order for a student to be counted as present, they must participate, do the online assignments, and be logged into Zoom with their camera on.

Middle School Response: "Video on" attendance is taken in classes throughout the day to track student presence. Daily assignments, some of which require student engagement with peers or the teacher, as well as research, reading, writing, summarizing, problem solving are



handed in, both during class and asynchronously through the LMS. Last year the AIPCS began a practice of weekly assessments. That practice is also continuing.

Grade level and department teams are coordinating time required and value (grading) as well as vertical alignment for units of study.

## Distance Learning Professional Development

[A description of the professional development and resources that will be provided to staff to support the distance learning program, including technological support.]

Elementary K-5 Response: AIMS held a two week boot camp for teachers. We had representatives from all of our online platforms come out to speak to the teachers and show them how to access the programs. We also trained students on how to effectively teach online, create lessons, make lessons interactive, and navigate through the various platforms. We also have professional development each Friday with a new topic based on curriculum and online learning. We have our own in-house technology assistant who helps teachers with various issues.

Middle School Response: Teachers and support staff have been receiving in house and vendor provided professional development from Powerschool, Schoology, Standards Plus, a curriculum provider, GoGuardian, as well as discussions and presentation from peers with experience in our context and administrators about increasing student engagement online, supporting sub-populations, safety issues and keeping safe when coming to campus for resources. Teachers have been introduced to the plans for potential return to campus plans (Middle School Scenario #1 above).

## Staff Roles and Responsibilities

[A description of the new roles and responsibilities of affected staff as a result of COVID-19.]

Elementary K-5 Response: Teachers are teaching virtually for the first semester. Administration staff will be on campus to welcome parents, get mail, and take phone calls.

Middle School Response: Few staff have been impacted as far as hiring and areas of responsibility. A few clerical staff are working more online and have been tasked with handling and processing more digital information (logins, web site information). Teachers continue to be a major resource for their classes, but they began using almost all of the current resource last fall (Fall 2019) before COVID-19. The newly hired Instructional Aide is required to visit classrooms virtually, but he would have done the same thing, had it been in person.

Attendance, always important, is more so now that it is possible for students to miss out on part of a class at a different time of day than the ADA required attendance meeting. Teachers are taking attendance in multiple classes, instead of just one, but they are using the same software program as always.

## Supports for Pupils with Unique Needs

[A description of the additional supports the LEA will provide during distance learning to assist pupils with unique needs, including English learners, pupils with exceptional needs served across the full continuum of placements, pupils in foster care, and pupils who are experiencing homelessness.]

Elementary K-5 Response: We have a dedicated ELD department that has been assisting English Language Learners throughout the virtual learning process. Each group of students has select pull out times throughout the week. The SPED program operates in a similar way. SPED services and IEP meetings are provided online through Zoom.

Middle School Response: Few staff have been impacted as far as hiring and areas of responsibility. A few clerical staff are working more online and have been tasked with handling and processing more digital information (logins, web site information). Teachers continue to be a major resource for their classes, but they began using almost all of the current resource last fall (Fall 2019) before COVID-19. The newly hired Instructional Aide is required to visit classrooms virtually, but he would have done the same thing, had it been in person.

Attendance, always important, is more so now that it is possible for students to miss out on part of a class at a different time of day than the ADA required attendance meeting. Teachers are taking attendance in multiple classes, instead of just one, but they are using the same software program as always.

### Actions Related to the Distance Learning Program [additional rows and actions may be added as necessary]

Description	Total Funds	Contributing
Classroom technology upgrades - TV Cart, Projectors, Projector brackets (MS \$1040.59)		
New computers for teachers and support staff	\$34,731.78	
Teachers and substitute teachers (MS \$703,839)	[\$ 0.00]	[Y/N]
Academic Deans/Instructional Coaches	228703.61	Y
Professional development for teachers, lead teacher, classified support staff, and administrators (elem \$15000)	\$20,000	
Services for English learners ELD support and development	(ES Portion \$53,025.24) MS \$7,016.80	
Stakeholder engagement - Resources assigned for parent engagement distance meetings and webinar workshops - PowerSchool - Student information system and ParentSquare and Ringcentral	\$21,000	
Schoology, Illuminate, ALEKS, Quill, Standards Plus, Scholastic Reading Inventory, GoGuardian - Educational Platforms	ES 8519.70 MS \$47,939	
Intervention Aides	(Elem \$164,895.65) (MS 25,164)	
Attendance clerks, support staff	MS \$87459	

	ES \$221,112.22	
ELD Teacher Salaries	(ES Portion \$53,025.24) MS \$37,022	[Y/N]
Intervention Staff Salaries	\$294,513.65	[Y/N]

## Pupil Learning Loss

[A description of how the LEA will address pupil learning loss that results from COVID-19 during the 2019–2020 and 2020–21 school years, including how the LEA will assess pupils to measure learning status, particularly in the areas of English language arts, English language development, and mathematics.]

Elementary K-5 Response: We will have frequent benchmarks from Illuminate to give to students every 6 weeks. Students who are behind will get specific intervention. They will have small group tutoring after school. They will also have weekly pull outs by intervention staff and be provided material to catch up.

Middle School Response: Based on assessment data used a regular part of our formative assessment program, which includes the Illuminate Benchmark program, Scholastic Reading Inventory, and now grade level continual assessments using ALEKS and weekly formative testing, there has been a small impact on the student population thus far, from COVID-19 caused closures. The continuing assessment plan remains the same. Last year, additional assessments were added which we are still testing to see how they add to the picture of student mastery, or lack thereof, especially in English Language Arts. Those tools include Quill and Standards Plus.

## Pupil Learning Loss Strategies

[A description of the actions and strategies the LEA will use to address learning loss and accelerate learning progress for pupils, as needed, including how these strategies differ for pupils who are English learners; low-income; foster youth; pupils with exceptional needs; and pupils experiencing homelessness.]

Elementary K-5 Response: We have purchased multiple online programs that are self-paced and have a progression system. Students are able to work at their math and reading levels. They advance based on their proficiency. Students are given extra time during the day to work on these programs independently. The teachers are given access to the data and can plan interventions from there.

Middle School Response: Support for students who are struggling with some learning loss, and for whom there is a need to accelerate learning progress are being addressed by tutoring after class hours, Saturday School support, and Teacher Office Hours. An Instructional Aide has been hired to help across classes. Special Education students also receive dedicated staff support. English Language Learners receive push in and pull out times as well as supplemental supports from targeted software.

## Effectiveness of Implemented Pupil Learning Loss Strategies

[A description of how the effectiveness of the services or supports provided to address learning loss will be measured.]

Elementary K-5 Response: Data is tracked weekly by multiple staff members. The data is shared with the teachers and teachers are given planning days to use the data. Teachers collaborate and make individualized learning plans based upon the data. Data is tracked based on points, proficiency, lexile levels, and math readiness.

Middle School Response: All students participate in assessments including, but not limited to diagnostic assessments, grade level benchmarks, and online standardized assessments with self-adjusting subject matter to target areas of learning loss or areas of need (ALEKS, Khan Academy).

### Actions to Address Pupil Learning Loss [additional rows and actions may be added as necessary]

Description	Total Funds	Contributing
Illuminate Benchmark Program + Quill + Learning Farm + Standards Plus + ALEKS + Scholastic Reading Inventory	MS - \$19,584 ES - \$8519.7	[Y/N]
Intervention Staff      Elementary \$164,895.65) (MS - \$129,618)	\$294,965.87	[Y/N]

## Mental Health and Social and Emotional Well-Being

[A description of how the LEA will monitor and support mental health and social and emotional well-being of pupils and staff during the school year, including the professional development and resources that will be provided to pupils and staff to address trauma and other impacts of COVID-19 on the school community.]

When classroom teachers, support staff or parents make referrals of students, reporting urgent or lower-tiered behaviors indicating mental health concerns, the Head of School and/or Dean of Students report directly to a state-licensed MFT counselor within 30 – 60 minutes. A referred student is then placed on a counselor’s client list and flagged for immediate contact. A clinical assessment is made, and a treatment plan is established, including a behavior modification plan, and this plan is shared with consenting parents and related school staff. If indicated, students begin meeting with a counselor and are in session with the counselor for 45 minutes per week. Currently, the counselor meets with an ongoing roster of approximately 70 active student clients.

Staff Professional Development modules are presented to staff regarding a wide range of mental health issues. Staff is also trained in ways to spot mental health concerns and make effective and timely student referrals to counselors.

Current state-of-the-art mental health strategies applying to the social and emotional learning in the context of Covid-19 are taught and provided to staff and students on a quarterly basis. These strategies are resourced from the CDC, State of California Mental Health Agency, and the UC Berkeley Greater Good Science Center.

The monitoring of student mental health and social emotional well-being will include regular collection of student emotional engagement data via regular surveys by staff of student engagement and participation. Regular emotional engagement surveys will help staff assess a student’s involvement in and enthusiasm for school as a whole as well as their emotional connectedness to other during distance learning.

Indicators monitored by staff to serve as emotional engagement metrics will include:

- Level of engagement with support staff/groups
- Participations in activities
- Participation in co-curricular and extra-curricular activities

## Pupil and Family Engagement and Outreach

[A description of pupil engagement and outreach, including the procedures for tiered reengagement strategies for pupils who are absent from distance learning and how the LEA will provide outreach to pupils and their parents or guardians, including in languages other than English, when pupils are not meeting compulsory education requirements, or if the LEA determines the pupil is not engaging in instruction and is at risk of learning loss.]

Elementary K-5 Response: As mentioned earlier, we have a very high virtual attendance rate. Any loss of learning is made up through our various programs. Teachers also have the ability to send work to students to complete if there are connection issues or absences.

Middle School Response: Administrators have been reaching out to families since the on-site closure on March. Nearly weekly emails and texts, leading up to parent meetings with translations into the major languages for our district before school began. Now, since the beginning of online instruction this Fall, teachers have been the major points of contact alongside supporting clerical staff and administrators.

Resource collection and distribution events are spaced to provide content unit materials. These events are separated into grade level and class groups and have been opportunities to check in as well as offer the “hard” resources (computers and books) and access to “soft” ones (passwords, login information, teacher contacts and school information).

## School Nutrition

[A description of how the LEA will provide nutritionally adequate meals for all pupils, including those students who are eligible for free or reduced-price meals, when pupils are participating in both in-person instruction and distance learning, as applicable.]

AIMS nutrition services will continue implementing procedures developed during the spring school closures to ensure safe and effective meal services. This include use of a drive-thru process for families that ensures 6-10 feet of social distancing for staff and community members, use of appropriate

personal protective equipment (PPE) by all staff, clear signage at all distribution points to reinforce social distancing practices, use of masks for community and staff required per state and county health guidelines.

All students in the district have access to nutritious meals. We are able to provide our students with access to a variety of affordable and appealing foods that meet the health and nutrition needs of students. All meals, foods and beverages sold or served at school meet state and federal requirements based on the USDA Dietary Guidelines. All meals, foods and beverages are prepared and served by qualified child nutrition professionals to ensure all students are provided access to healthy meals. All meals are provided throughout the term of distance learning. Families are given five day meal kits to ensure accessibility and all CDC requirements are met to ensure families are distributed meals safely. Our district has provided families with the convenience of applying for lunch applications online and in person. All families that qualify for free or reduced meals are informed and encouraged to pick up meals. All families that qualify for paid meals are encouraged to participate in the NSLP (National School Lunch Program), payments are set at a minimum for paid families to ensure meals are affordable for families that do not qualify for free or reduced priced meals. During distance learning all meals are distributed once a week and families are given five day meal kits. All meal kits cover the components that ensure healthy meals per serving. During in person instruction, meals will be distributed in person to all students. All food handlers and staff supporting are qualified and certificated and approved by Alameda County Environmental Health to distribute food during COVID-19. All staff have been trained and will follow CDC guidelines to ensure proper food handling and distribution.

## Additional Actions to Implement the Learning Continuity Plan [additional rows and actions may be added as necessary]

Section	Description	Total Funds	Contributing
N/A	Hired Instructional Aide	\$24,177.58]	[Y]
[The section of the Learning Continuity Plan related to the action described; may put N/A if the action does not apply to one specific section]	[A description of what the action is; may include a description of how the action contributes to increasing or improving services]	[\$ 0.00]	[Y/N]

## Increased or Improved Services for Foster Youth, English Learners, and Low-Income Students

Percentage to Increase or Improve Services	Increased Apportionment Based on the Enrollment of Foster Youth, English Learners, and Low-Income students
[Insert percentage here]%	[Insert dollar amount here]

### Required Descriptions

[For the actions being provided to an entire school, or across the entire school district or county office of education (COE), an explanation of (1) how the needs of foster youth, English learners, and low-income students were considered first, and (2) how these actions are effective in meeting the needs of these students.]

Elementary K-5 Response: We purchased laptops for all students to ensure access to a quality education. Parents and students were trained during the first week of school so that they can navigate through the programs effectively. Extra intervention staff were hired in order to work with students so they do not fall behind. A dedicated ELD program was developed and converted to using virtual teaching strategies to meet the needs of our ELL population.

Middle School Response: 1) Clerical staff, responsible for attendance calls have been given call scripts to consistently offer supports to students and their families. ELD staff have met with each teacher to maximize intervention efforts and resources. Current and new ELD students (receiving integrated and designated services) have been identified and planning begun. English Language Learners receive push in and pull out times as well as supplemental supports from targeted software. Struggling students are being addressed by tutoring after scheduled class hours, Saturday School support, and Teacher Office Hours. An Instructional Aide has been hired to help across classes. Special Education students also receive dedicated staff support. School resource days also support students in these groups ensuring students are supplied with the required materials. 2) Staff scripts help consistency in approach and questions asked of families and students - following up on attendance or resource needs, in addition to maintaining school contact records. ELD strategies and support have already been working in maintaining higher levels of performance among that group within our school. Our goal is to maintain and improve that work this year. Low income and foster youth, where those groups crossover, as well as refugee families are less clearly identifiable, so using the scripts and teacher contact will continue to be a focus. This focus is actually a new development in how we do attendance and contact calling.

[A description of how services for foster youth, English learners, and low-income students are being increased or improved by the percentage required.]

Elementary K-5 Response: We have a dedicated ELD department who were trained on virtual learning. We also purchased new online programs to help students in need.

Middle School Response: Services to these sub-groups have been increased especially for English Learners who are easily identified. Low-income students have been a part of our school (70+% Title 1), so including their concerns are typical for all planning and budgeting. Because we are doing as much or more follow-up since students can more easily drop off of one class or another, there are more opportunities to find out more about a student's situation. Clerical staff are making at least as many phone calls. Teachers are making more calls to students and writing more emails to students and families. The entire educational program has been receiving more scrutiny and intentional decision making since last Fall (2019), renewed in February and March, and then into the beginning of this academic year (2020-2021).



California Department of Education, July 2020

# Learning Continuity and Attendance Plan Template (2020–21)

The instructions for completing the Learning Continuity and Attendance Plan is available at <https://www.cde.ca.gov/re/lc/documents/lrngcntntyatndncpln-instructions.docx>.

Local Educational Agency (LEA) Name	Contact Name and Title	Email and Phone
American Indian Public Charter School	Peter Holmquist, Head of School	peter.holmquist@aimsk12.org

## General Information

[A description of the impact the COVID-19 pandemic has had on the LEA and its community.]

The unprecedented COVID-19 pandemic has impacted our school community and dramatically affected and altered the lives of our students, families and staff. The closure of schools have negatively impacted the emotional, physical, social and educational environment. Closure of our schools has resulted in families being challenged in access to basic services, and conducive school environments that are not meeting the standards that allow students to learn effectively. Families, students and staff have all been affected with higher levels of anxiety and stress due to lack of resources, inability to support their children academically during distance learning, and financial hardships due to massive layoffs due to the pandemic.

Staff and faculty are now faced with surmountable challenges however we continue to ensure in spite of these unpredictable changes that our students are supported instructional continuity in a remote learning environment by focusing coursework on new learning, as opposed to review and reinforcement. Providing and leveraging the technology needs and resources available and support resources. This includes providing a variety of support resources in order for instruction and material to be available to all students, including our special education population, students with 504 plans, English Language Learners, students with social emotional needs, and students who are in need of technology access.

We empathize with our school community who have been impacted by COVID-19 pandemic and want to reiterate that the safety of the AIPCS community is our No. 1 priority. AIPCS continues to be committed to providing high-quality learning experiences for all of our students during school closures. The plan provides opportunities for students to acquire the knowledge and skills needed to succeed at the next grade level/subsequent course, while building in flexibility to accommodate the unique circumstances of every student.

## Stakeholder Engagement

[A description of the efforts made to solicit stakeholder feedback.]



Teachers have been involved in the development of the plan for distance learning since before March. Their processing of the details, experience of the online platforms, and the foibles of each service featured in the planning of the potential on-site learning options. Without inundating teachers over their summer break, emails and other meeting offerings were shared that gave opportunities to hear updates on plans being made for “re-opening” in the Fall of 2020.

Parents and students were some of the first people beyond staff, who were informed about the developing plans for safety as we considered how to return to on-site classrooms. Taking teacher input, as well as the strong instructions from county and state officials, plans were crafted through July, 2020. These were shared with all parents over the summer as they were developing. These were communicated through multiple videos, zoom meetings, ParentSquares, and direct emails. The two most recent meetings intended to share as widely as possible included translations into Chinese and Spanish and over 90 minutes of question and answer time. These question and answer sessions were then incorporated into the ongoing message to respond to parent and student concerns.

A new email address was set up in April to serve as a clearinghouse for information about the Middle School. Staff received training on how to address the needs or directed to whom the questions should go. Appointments were scheduled for resource drop off and pick-up through that email address.

[A description of the options provided for remote participation in public meetings and public hearings.]

All Board meetings, committee meetings while also posted onsite, were posted online on the district website, with video conferencing, or zoom links. Parent meetings were posted through ParentSquare and reached 620 people’s devices. Translation of announcements and meeting scripts were translated. Meeting links were translated.

[A summary of the feedback provided by specific stakeholder groups.]

Parents appreciated the opportunities to hear administrators and the district respond to their concerns. Main items or topics of concern included: 1) the desire to keep a student home rather than send them to school when that became a possibility, 2) a concern for some aspect of technology (ease of use, access, availability, wi-fi), or 3) support for struggling students in this online classroom time.

[A description of the aspects of the Learning Continuity and Attendance Plan that were influenced by specific stakeholder input.]

The District legal team is working to complete a permission form to allow a student to “opt-out” of on-site classrooms. (State laws obviously impact the form’s development as well.) Teacher concerns for a safe work environment continue to clarify the need for front and back office practices in cleanliness and safety. Parent concerns for (#1 above) keeping students home was addressed repeatedly orally, and in messaging to communicate the process and confirmation of the parent choice when it became available. Parent concerns for one aspect of technology (#2 above) was addressed by providing digital resources for students and devices with which to reach them. Another aspect of technology concern was the provision for parent links - access - to their student’s information. In addition, our school continues to have information sessions and tutorials to help parents (and students) with logging into the online platform (LMS) that serves as the focus of much of the handing in and passing out of digital resources and assignments. The district continues to support individual families with referrals to low cost internet plans and hot spots as main strategies to the problem of internet access. Support for students who do not seem to be flourishing in this digital environment is being addressed by tutoring after class hours, Saturday school support, and other Teacher Office

Hours. An Instructional Aide has been hired to help in various classes. English language learners and Special Education students also receive dedicated staff support.

## Continuity of Learning

### In-Person Instructional Offerings

[A description of the actions the LEA will take to offer classroom-based instruction whenever possible, particularly for students who have experienced significant learning loss due to school closures in the 2019–2020 school year or are at a greater risk of experiencing learning loss due to future school closures.]

We prepared two scenarios for returning to school this Fall 2020. The First Scenario is for on-site instruction: “Hybrid” schedules will feature in-class & online instruction rotation for three student groups from each class. A,B, and C groups will rotate through the school, one day in school, two days at home. This schedule will repeat and have equitable instructional minutes on campus over three weeks. In this scenario Fridays will all be virtual.

Students will be grouped for scenario 1, into heterogeneous groupings across their grade level, preserving the previous year classes, and AIMS’ preference for “looping” classes. Teachers will be consulted in the exact mix of students to ensure maximum feasibility and minimize distraction. ELD and Resource staff schedules will also be take into consideration in group construction and schedules to maximize intervention efforts and resources.

Support for students who do not seem to be flourishing in this digital environment is being addressed by tutoring after class hours, Saturday school support, and other Teacher Office Hours. An Instructional Aide has been hired to help in class. Special Education students also receive dedicated staff support. English Language Learners receive specific instruction as well as supplemental supports from targeted software.

### Actions Related to In-Person Instructional Offerings [additional rows and actions may be added as necessary]

Description	Total Funds	Contributing
Student Chromebooks, computer refresh, internet hotspot purchases, and ongoing internet services in 2020-21 school year	\$9,216.41	Y
Classroom technology upgrades - projectors, projector brackets	\$1040.59	Y
New computers for teachers and support staff	\$10,290	Y
Teachers and substitute teachers	\$703,839.87	Y
Academic Deans/Instructional Coaches	\$100,712.04	Y
Professional development for teachers, lead teacher, classified support staff, and administrators	\$3,000.00	Y

Services for English learners ELD support and development	\$5162.15	Y
Stakeholder engagement - Resources assigned for parent engagement distance meetings and webinar workshops - PowerSchool - Student information system and ParentSquare and Ringcentral	\$7000.00	Y
Schoology, Illuminate, ALEKS, Quill, Standards Plus, Scholastic Reading Inventory, GoGuardian - Educational Platforms	\$47,939.98	Y
Intervention Aides, attendance clerks, support staff	\$87,459.00	Y
Intervention Staff Salaries	\$129,618	Y
Counselor + Supplies (salary + \$1161)	\$38,462	Y
The school has prepared for possible in-person learning by purchasing cleaning supplies, upgraded HVAC filters, and protection materials (including plexiglass, and PPE). Upgraded cleaning is essential for safety.	\$60,000	[Y/N]

## Distance Learning Program

### Continuity of Instruction

[A description of how the LEA will provide continuity of instruction during the school year to ensure pupils have access to a full curriculum of substantially similar quality regardless of the method of delivery, including the LEA’s plan for curriculum and instructional resources that will ensure instructional continuity for pupils if a transition between in-person instruction and distance learning is necessary.]

### LMS - Schoology:

- AIMS Middle School currently has Schoology as our Learning Management System that is utilized to continue instructions in remote as well as classroom settings.
- Various supporting tools/programs are integrated with Schoology to enable teachers & students to access as well as edit the documents etc.
- Students’ & teachers’ google drives are enabled on Schoology platforms. Middle School teachers received an extended Schoology training last year and there was additional training at the beginning of, and ongoing PD during the 2020-21 school year.

#### Content Specific Digital Learning Resources suitable for Blended Learning

- Illuminate
- Powerschool
- ALEKS (Math)
- McGrawHill (Science)
- Standards Plus (ELA)
- SRI (Reading)
- Quill (Writing)
- Rosetta Stone (World Language & ELD)

## Access to Devices and Connectivity

[A description of how the LEA will ensure access to devices and connectivity for all pupils to support distance learning.]

The district and school have invited responses to multiple surveys in which families can mention or describe their need. Teachers have been alerted to watch and make provision to include students who seem to have connectivity issues. Distribution of resources takes place on a publicized day for grade levels to come in and check out a device. At that time passwords and login information has been given out. Families who miss the official day, or who have problems with their technology are invited to contact [middleschool@aimsk12.org](mailto:middleschool@aimsk12.org) to make an appointment, or get a response seeking more information before requiring replacement of the device. At this time around 300 devices have been distributed to the MS alone (252 over three days).

## Pupil Participation and Progress

[A description of how the LEA will assess pupil progress through live contacts and synchronous instructional minutes, and a description of how the LEA will measure participation and time value of pupil work.]

“Video camera on” attendance is taken in classes throughout the day to track student presence. Daily assignments, some of which require student engagement with peers or the teacher, as well as research, reading, writing, summarizing, problem solving are handed in, both during class and asynchronously through the LMS. Last year the AIPCS began a practice of weekly assessments. That practice is also continuing.

Grade level and department teams are coordinating time required and value (grading) as well as vertical alignment for units of study.

The curriculum and pace of our normal curriculum is intended to continue in this new setting/environment.

## Distance Learning Professional Development

[A description of the professional development and resources that will be provided to staff to support the distance learning program, including technological support.]

Teachers and support staff have been receiving in house and vendor provided professional development from Powerschool, Schoology, Standards Plus, a curriculum provider, GoGuardian, as well as discussions and presentation from peers with experience in our context and administrators about increasing student engagement online, supporting sub-populations, safety issues and keeping safe when coming to campus for resources. Teachers have been introduced to the plans for potential return to campus plans (Scenario #1 above).

## Staff Roles and Responsibilities

[A description of the new roles and responsibilities of affected staff as a result of COVID-19.]

Few staff have been impacted as far as hiring and areas of responsibility. A few clerical staff are working more online and have been tasked with handling and processing more digital information (logins, web site information). Teachers continue to be a major resource for their classes, but they began using almost all of the current resource last fall (Fall 2019) before COVID-19. The newly hired Instructional Aide is required to visit classrooms virtually, but he would have done the same thing, had it been in person.

Attendance, always important, is more so now that it is possible for students to miss out on part of a class at a different time of day than the ADA required attendance meeting. Teachers are taking attendance in multiple classes, instead of just one, but they are using the same software program as always.

### Supports for Pupils with Unique Needs

[A description of the additional supports the LEA will provide during distance learning to assist pupils with unique needs, including English learners, pupils with exceptional needs served across the full continuum of placements, pupils in foster care, and pupils who are experiencing homelessness.]

Teachers are alerted to identified students who have been “found” (student find), as well as having been alerted to the particular needs of some students in our community. Clerical staff, responsible for attendance calls have been given call scripts to consistently offer supports to students and their families.

While students are in heterogeneous groupings across their grade level, teachers are being consulted in the exact mix of students to ensure maximum feasibility and minimize distraction. ELD staff have met with each teacher to maximize intervention efforts and resources.

Support for students who are not flourishing is being addressed by tutoring after class hours, Saturday School support, and Teacher Office Hours. An Instructional Aide has been hired to help across classes. Special Education students also receive dedicated staff support. English Language Learners receive push in and pull out times as well as supplemental supports from targeted software.

### Actions Related to the Distance Learning Program [additional rows and actions may be added as necessary]

Description	Total Funds	Contributing
Student Chromebooks, computer refresh, internet hotspot purchases, and ongoing internet services in 2020-21 school year	\$9216.41	Y
Classroom technology upgrades - projectors, projector brackets	\$1040.59	Y
New computers for teachers and support staff	\$10,290	Y
Teachers and substitute teachers	\$703,839.87	Y
Academic Deans/Instructional Coaches	\$100,712.04	Y
Professional development for teachers, lead teacher, classified support staff, and administrators	\$5,000.00	Y
Services for English learners ELD support and development	\$37,023.00	Y

Stakeholder engagement - Resources assigned for parent engagement distance meetings and webinar workshops - PowerSchool - Student information system and ParentSquare and Ringcentral	\$7000.00	Y
Schoology, Illuminate, ALEKS, Quill, Standards Plus, Scholastic Reading Inventory, GoGuardian - Educational Platforms	\$47,939.98	Y
Intervention Aides, attendance clerks, support staff	\$129,618.33	Y
Counselor + Supplies (\$37,301 for MS portion + \$1161)	\$38,462.00	Y

## Pupil Learning Loss

[A description of how the LEA will address pupil learning loss that results from COVID-19 during the 2019–2020 and 2020–21 school years, including how the LEA will assess pupils to measure learning status, particularly in the areas of English language arts, English language development, and mathematics.]

Based on assessment data used a regular part of our formative assessment program, which includes the Illuminate Benchmark program, Scholastic Reading Inventory, and now grade level continual assessments using ALEKS and weekly formative testing, there has been a small impact on the student population thus far, from COVID-19 caused closures. The continuing assessment plan remains the same. Last year, additional assessments were added which we are still testing to see how they add to the picture of student mastery, or lack thereof, especially in English Language Arts. Those tools include Quill and Standards Plus.

### Pupil Learning Loss Strategies

[A description of the actions and strategies the LEA will use to address learning loss and accelerate learning progress for pupils, as needed, including how these strategies differ for pupils who are English learners; low-income; foster youth; pupils with exceptional needs; and pupils experiencing homelessness.]

Support for students who are struggling with some learning loss, and for whom there is a need to accelerate learning progress are being addressed by tutoring after class hours, Saturday School support, and Teacher Office Hours. An Instructional Aide has been hired to help across classes. Special Education students also receive dedicated staff support. English Language Learners receive push in and pull out times as well as supplemental supports from targeted software.

### Effectiveness of Implemented Pupil Learning Loss Strategies

[A description of how the effectiveness of the services or supports provided to address learning loss will be measured.]

All students participate in assessments including, but not limited to diagnostic assessments, grade level benchmarks, and online standardized assessments with self-adjusting subject matter to target areas of learning loss or areas of need (ALEKS, Khan Academy).

## Actions to Address Pupil Learning Loss [additional rows and actions may be added as necessary]

Description	Total Funds	Contributing
Illuminate Benchmark Program + ALEKS + Standards Plus + Scholastic Reading Inventory	\$18,973.97	Y
Intervention Staff	\$129,618	Y

## Mental Health and Social and Emotional Well-Being

[A description of how the LEA will monitor and support mental health and social and emotional well-being of pupils and staff during the school year, including the professional development and resources that will be provided to pupils and staff to address trauma and other impacts of COVID-19 on the school community.]

When classroom teachers, support staff or parents make referrals of students, reporting urgent or lower-tiered behaviors indicating mental health concerns, the Head of School and/or Dean of Students report directly to a state-licensed MFT counselor within 30 – 60 minutes. A referred student is then placed on a counselor’s client list and flagged for immediate contact. A clinical assessment is made, and a treatment plan is established, including a behavior modification plan, and this plan is shared with consenting parents and related school staff. If indicated, students begin meeting with a counselor and are in session with the counselor for 45 minutes per week. Currently, the counselor meets with an ongoing roster of approximately 70 active student clients.

Staff Professional Development modules are presented to staff regarding a wide range of mental health issues. Staff is also trained in ways to spot mental health concerns and make effective and timely student referrals to counselors.

Current state-of-the-art mental health strategies applying to the social and emotional learning in the context of Covid-19 are taught and provided to staff and students on a quarterly basis. These strategies are resourced from the CDC, State of California Mental Health Agency, and the UC Berkeley Greater Good Science Center.

The monitoring of student mental health and social emotional well-being will include regular collection of student emotional engagement data via regular surveys by staff of student engagement and participation. Regular emotional engagement surveys will help staff assess a student’s involvement in and enthusiasm for school as a whole as well as their emotional connectedness to others on campus during distance learning.

Indicators monitored by staff to serve as emotional engagement metrics will include:

- Level of engagement with support staff/groups
- Participations in activities
- Participation in co-curricular and extra-curricular activities



# Pupil and Family Engagement and Outreach

[A description of pupil engagement and outreach, including the procedures for tiered reengagement strategies for pupils who are absent from distance learning and how the LEA will provide outreach to pupils and their parents or guardians, including in languages other than English, when pupils are not meeting compulsory education requirements, or if the LEA determines the pupil is not engaging in instruction and is at risk of learning loss.]

Administrators have been reaching out to families since the on-site closure in March. Nearly weekly emails and texts, leading up to parent meetings with translations into the major languages for our district before school began. Now, since the beginning of online instruction this Fall, teachers have been the major points of contact alongside supporting clerical staff and administrators.

Resource collection and distribution events are spaced to provide content unit materials. These events are separated into grade level and class groups and have been opportunities to check in as well as offer the “hard” resources (computers and books) and access to “soft” ones (passwords, login information, teacher contacts and school information).

## School Nutrition

[A description of how the LEA will provide nutritionally adequate meals for all pupils, including those students who are eligible for free or reduced-price meals, when pupils are participating in both in-person instruction and distance learning, as applicable.]

AIMS nutrition services will continue implementing procedures developed during the spring school closures to ensure safe and effective meal services. This include use of a drive-thru process for families that ensures 6-10 feet of social distancing for staff and community members, use of appropriate personal protective equipment (PPE) by all staff, clear signage at all distribution points to reinforce social distancing practices, use of masks for community and staff required per state and county health guidelines.

All students in the district have access to nutritious meals. We are able to provide our students with access to a variety of affordable and appealing foods that meet the health and nutrition needs of students. All meals, foods and beverages sold or served at school meet state and federal requirements based on the USDA Dietary Guidelines. All meals, foods and beverages are prepared and served by qualified child nutrition professionals to ensure all students are provided access to healthy meals. All meals are provided throughout the term of distance learning. Families are given five day meal kits to ensure accessibility and all CDC requirements are met to ensure families are distributed meals safely. Our district has provided families with the convenience of applying for lunch applications online and in person. All families that qualify for free or reduced meals are informed and encouraged to to pick up meals. All families that qualify for paid meals are encouraged to participate in the NSLP (National School Lunch Program), payments are set at a minimum for paid families to ensure meals are affordable for families that do not qualify for free or reduced priced meals. During distance learning all meals are distributed once a week and families are given five day meal kits. All meal kits cover the components that ensure healthy meals per serving. During in person instruction, meals will be distributed in person to all students. All food handlers and staff supporting are qualified and certificated and approved by Alameda County Environmental Health to distribute food during COVID-19. All staff have been trained and will follow CDC guidelines to ensure proper food handling and distribution.

## Additional Actions to Implement the Learning Continuity Plan [additional rows and actions may be added as necessary]

Section	Description	Total Funds	Contributing
---------	-------------	-------------	--------------



N/A	Hired Instructional Aide	\$24,177.58]	[Y]
[The section of the Learning Continuity Plan related to the action described; may put N/A if the action does not apply to one specific section]	[A description of what the action is; may include a description of how the action contributes to increasing or improving services]	[\$ 0.00]	[Y/N]

## Increased or Improved Services for Foster Youth, English Learners, and Low-Income Students

Percentage to Increase or Improve Services	Increased Apportionment Based on the Enrollment of Foster Youth, English Learners, and Low-Income students
[Insert percentage here]%	[Insert dollar amount here]

### Required Descriptions

[For the actions being provided to an entire school, or across the entire school district or county office of education (COE), an explanation of (1) how the needs of foster youth, English learners, and low-income students were considered first, and (2) how these actions are effective in meeting the needs of these students.]

- 1) Clerical staff, responsible for attendance calls have been given call scripts to consistently offer support to students and their families. ELD staff have met with each teacher to maximize intervention efforts and resources. Current and new ELD students (receiving integrated and designated services) have been identified and planning begun. English Language Learners receive push in and pull out times as well as supplemental supports from targeted software. Struggling students are being addressed by tutoring after scheduled class hours, Saturday School support, and Teacher Office Hours. An Instructional Aide has been hired to help across classes. Special Education students also receive dedicated staff support. School resource days also support students in these groups ensuring students are supplied with the required materials.
- 2) Staff scripts help consistency in approach and questions asked of families and students - following up on attendance or resource needs, in addition to maintaining school contact records. ELD strategies and support have already been working in maintaining higher levels of performance among that group within our school. Our goal is to maintain and improve that work this year. Low income and foster youth, where those groups crossover, as well as refugee families are less clearly identifiable, so using the scripts and teacher contact will continue to be a focus. This focus is actually a new development in how we do attendance and contact calling.

[A description of how services for foster youth, English learners, and low-income students are being increased or improved by the percentage required.]

Services to these sub-groups have been increased especially for English Learners who are easily identified. Low-income students have been a part of our school (70+% Title 1), so including their concerns are typical for all planning and budgeting. Because we are doing as much or

more follow-up since students can more easily drop out of one class or another, there are more opportunities to find out more about a student's situation. Clerical staff are making at least as many phone calls. Teachers are making more calls to students and writing more emails to students and families. The entire educational program has been receiving more scrutiny and intentional decision making since last Fall (2019), renewed in February and March, and then into the beginning of this academic year (2020-2021).

# Coversheet

## Ring Central Contract

<b>Section:</b>	III. Action Items
<b>Item:</b>	G. Ring Central Contract
<b>Purpose:</b>	Vote
<b>Submitted by:</b>	
<b>Related Material:</b>	RingCentral Final Quote.pdf RingCentral Cover Letter.pdf

**QUOTE**

**Prepared for**

Quote Name: American Indian Model Schools 1

American Indian Model Schools

Valid Until: August 31<sup>st</sup>, 2020

AIMS K12 College Prep RAdmin

[cisip@inconnectivity.com](mailto:cisip@inconnectivity.com)

Start Date: August 14<sup>th</sup>, 2020

16504583319

Initial Term: 36 Months

Renewal Term: 36 Months

Currency: USD

Payment Plan: Monthly

RingCentral Office Services				
Product	Charge Term	Quantity	Unit Price	Total
DigitalLine Unlimited Standard	Monthly	35	\$22.99	\$804.65
e911 Service Fee	Monthly	35	\$1.00	\$35.00
Compliance and Administrative Cost Recovery Fee	Monthly	35	\$4.00	\$140.00
Total One - Time Payment*:				\$0.00
Total Monthly Price*:				\$979.65
*Does not include Taxes and Fees.				

Special Terms and Notes: 1) Customer's subscription entitles it to all features that are ascribed to the Office Standard Edition as they are described in the RingCentral website, as well as the features that follow:

1. Inbound Caller ID Name
2. Single Sign-On

## MASTER SERVICES AGREEMENT

**THIS MASTER SERVICES AGREEMENT** (together with its Attachments, the “Agreement”) is made by and between RingCentral, Inc., a Delaware corporation with its primary office at 20 Davis Drive, Belmont, CA 94002, (“RingCentral”), and MeridianLink, Inc. located at the address set forth in the Order Form (“Customer”). RingCentral and Customer may be individually referred to as a “Party” or collectively as the “Parties.” This Agreement is effective as of the last date of signature below (“Effective Date”).

### 1. Provision of the Service

#### A. General Terms

The purchase, provision, and use of the Services is subject to the terms contained in this Agreement, the Order Forms, the Online Terms of Services, included at <https://www.ringcentral.com/legal/eulatos.html> (the “Online Terms of Service”), and the Service Attachments applicable to Customer’s Services. All these documents are hereby incorporated into and form a part of this Agreement. RingCentral may update the Online Terms of Services from time to time, and will provide notice to Customer at the email address on file with the Account. Such updates will become effective thirty (30) days after such notice to Customer.

Capitalized terms not defined in this Agreement have the meaning given to them in the Online Terms of Service.

### 2. Ordering and Term

#### A. Ordering Services

Customer may order the Services set forth in the relevant Attachments, attached hereto, by executing an Order Form in the format provided by RingCentral. Customer must submit the Order Form to RingCentral either in writing or electronically via the Administrative Portal. The Order Form will identify the Services requested by Customer together with: (i) the price for each Service; (ii) scheduled Start Date; (iii) and products rented, licensed or sold to Customer, if any. An Order Form will become binding when it is executed by the Customer and accepted by RingCentral. RingCentral may accept an Order Form by commencing performance of the requested Services. The Services and invoicing for those Services will begin on the Start Date, as identified in the applicable Order Form or on the day Services are ordered via the Administrative Portal. Customer may purchase additional Services, software, and equipment via the Administrative Portal or by executing additional Order Forms.

#### B. Term of this Agreement.

The Term of this Agreement will commence on the Effective Date and continue until the last Order Form is terminated or expires, unless terminated earlier in accordance with its terms.

#### C. Services Term

The Services Term will begin on the Start Date of the initial Order Form and continue for the initial term set forth in the initial Order Form (“Initial Term”). Upon expiration of the Initial Term, recurring Services will automatically renew for successive periods as set forth in the initial Order Form (each a “Renewal Term”) unless either Party gives notice of non-renewal at least thirty (30) days before the expiration of the Initial Term or the then-current Renewal Term. The term of any recurring Services added to your Account after the initial Order Form is executed will start on the Start Date in the applicable Order Form, will run coterminously with the then-current Term of any preexisting Services unless otherwise extended in the applicable Order Form, and will be invoiced on the same billing cycles as the preexisting Services.

#### D. Service Attachments

In addition to the Service Attachments referenced in the Online Terms of Services, the Parties may agree to add additional Service Attachments to this Agreement.

Service Attachment A: Office Services

Service Attachment B: Contact Center Services

Service Attachment C: Professional Services Agreement

Attachment D: Service Level Agreement for Office Services

### 3. Invoicing and Payment

#### A. Prices and Charges.

All prices are identified in US dollars on the Administrative Portal or in the applicable Order Form unless otherwise agreed by the Parties. Additional charges may result if Customer activates additional features, exceeds usage thresholds, or purchases additional Services or equipment. Customer will be liable for all charges resulting from use of the Services on its Account.

Unless otherwise agreed between the Parties, recurring charges for the Services begin on the Start Date identified in the Administrative Portal or in the applicable Order Form, and will continue for the Term. Recurring charges (such as charges for Digital Lines, product licenses, minute bundles, and equipment rental fees) will, unless otherwise agreed between the Parties, once incurred, remain in effect for the then-current Term. RingCentral will provide notice of any proposed increase in such charges no later than sixty (60) days before the end of the Initial Term or then-current Renewal Term, and any such increase will be effective on the first day of the next Renewal Term.

Administrative Fees that RingCentral is entitled to pass on to its customers as a surcharge pursuant to applicable Law may be increased on thirty (30) days’ written notice.

Outbound calling rates will be applied based on the rate in effect at the time of use. Customer may locate the currently effective rates in the Administrative Portal.

#### B. Invoicing and Payment

Invoices will be issued in accordance with the payment terms set forth in the Order Form. If Customer chooses to pay by credit or debit card, by providing a valid credit or debit card, Customer is expressly authorizing all Services and equipment charges and fees to be charged to such payment card, including recurring payments billed on a monthly or annual basis. In addition, Customer’s provided credit card shall be used for any in month purchases of additional services and products, or where Customer has exceeded usage or threshold limits, any overage charges. Unless otherwise stated in the applicable Order Form, recurring charges are billed in advance in the frequency set forth in the Order Form, and usage-based and onetime charges are billed monthly in arrears. Customer shall make payment in full, without deduction or set-off, within thirty (30) days of the invoice date. Any payment not made when due may be subject to a late payment fee equivalent to the lesser of (i) one and a half percent (1.5%) per month or (ii) if applicable, the highest rate allowed by Law. In no event may payment be subject to delays due to Customer internal purchase order process.

#### C. Taxes

All rates, fees, and charges are exclusive of applicable Taxes, for which Customer is solely responsible. Taxes may vary based on jurisdiction and the Services provided. If any withholding tax is levied on the payments, then Customer must increase the sums paid to RingCentral so that the amount received by RingCentral after the withholding tax is deducted is the full amount RingCentral would have received if no withholding or deduction had been made. If Customer is a tax-exempt entity, tax exemption will take effect upon provision to and validation by RingCentral of certificate of tax exemption.

### 4. Termination

#### A. Termination for Cause

Either Party may terminate this Agreement and any Services purchased hereunder in whole or part by giving written notice to the other Party: i) if

the other Party breaches any material term of this Agreement and fails to cure such breach within thirty (30) days after receipt of such notice; ii) at the written recommendation of a government or regulatory agency following a change in either applicable Law or the Services; or iii) upon the commencement by or against the other Party of insolvency, receivership or bankruptcy proceedings or any other proceedings or an assignment for the benefit of creditors.

**B. Effect of Termination**

If Customer terminates the Services, a portion of the Services, or this Agreement in its entirety due to RingCentral’s material breach under Section 4(A), Customer will not owe any fees or charges for the Services in respect of any period subsequent to the date of such written notice (except those arising from continued usage before the cancelled Services are disconnected), and will be entitled to a pro-rata refund of any prepaid and unused fees for the cancelled Services being terminated.

If this Agreement or any Services are terminated for any reason other than under this Section 4, the Customer must, to the extent permitted by applicable Law and without limiting any other right or remedy of RingCentral, pay within thirty (30) days of such termination all amounts that have accrued prior to such termination, as well as all sums remaining unpaid for the Services for the remainder of the then-current Term plus related Taxes and fees.

**C. Trial Period**

In addition to the above, Customer may cancel any Services purchased under this Agreement with written notice to RingCentral within thirty (30) days of the date in which the purchase becomes effective. Except as otherwise provided in the Agreement between the Parties, in the event of a timely cancellation, Customer shall not owe any fees or charges for the Services being canceled in respect of any period subsequent to the date of such written notice (except those arising from continued Usage), and shall

be entitled to a pro-rata refund of any prepaid and unused fees for the Services subject to the cancellation. All purchases are final after 30 days.

**5. Miscellaneous**

**A. Entire Agreement**

The Agreement, together with any exhibits, Order Forms, and Attachments, each of which is expressly incorporated into this Agreement with this reference, constitutes the entire agreement between the Parties and supersedes and replaces any and all prior or contemporaneous understandings, proposals, representations, marketing materials, statements, or agreements, whether oral, written, or otherwise, regarding such subject.

**B. Order of Precedence**

In the event of a conflict between these documents, the following shall have precedence in interpretation: (a) the applicable Order Form, (b) any applicable Service Attachments, (c) this Master Services Agreement, and (d) the Online Terms of Service.

**C. Execution**

Each Party represents and warrants that: (a) it possesses the legal right and capacity to enter into the Agreement and to perform all of its obligations thereunder; (b) the individual signing the Agreement and (each executable part thereof) on that Party’s behalf has full power and authority to execute and deliver the same; and (c) the Agreement will be a binding obligation of that Party. Each Party agrees that an Electronic Signature, whether digital or encrypted, is intended to authenticate this Agreement and to have the same force and effect as manual signatures.

**D. Counterparts**

This Agreement may be executed electronically and in separate counterparts each of which when taken together will constitute one in the same original.

**IN WITNESS WHEREOF**, the Parties have executed this Agreement below through their duly authorized representatives.

**Customer**

**MeridianLink, Inc.**

By: \_\_\_\_\_

Name: \_\_\_\_\_

Title: \_\_\_\_\_

Date: \_\_\_\_\_

**RingCentral**

**RingCentral, Inc.**

By: \_\_\_\_\_

Name: \_\_\_\_\_

Title: \_\_\_\_\_

Date: \_\_\_\_\_

**ATTACHMENT A****SERVICE ATTACHMENT – RINGCENTRAL OFFICE SERVICES**

This Service Attachment is a part of the Master Services Agreement that includes the terms and conditions agreed by the Parties under which RingCentral will provide the RingCentral Office Services to Customer.

**1. Service Overview**

RingCentral Office is a cloud-based unified communications service that includes enterprise-class voice, fax, text, call handling, mobile apps, and BYOD capability that integrates with a growing list of applications.

RingCentral Office includes

- Voice Services, including extension-to-extension calling and the ability to make and receive calls to and from the public switched telephone network (PSTN)
- Video and audio conferencing service, including screen sharing
- Collaboration Tools, including One-to-One and Team Chat, File Sharing, task management, SMS/Texting (where available) and other innovative tools

RingCentral Office Services may be accessed from a variety of user End Points, including IP Desk Phones, Desktop Clients, Web Clients, Mobile Applications, and Software Integrations.

**2. Office Purchase Plans****A. Tiers of Service**

RingCentral Office is made available in several pricing tiers, which are described more fully at <https://www.ringcentral.com/office/plansandpricing.html>.

While RingCentral offers unlimited monthly plans for some of its products and services, RingCentral Services are intended for regular business use. "Unlimited" use does not permit any use otherwise prohibited by the Acceptable Use Policy, available at <https://www.ringcentral.com/legal/acceptable-use-policy.html>, including trunking, access stimulation, reselling of the Services, etc.

**B. Minute and Calling Credit Bundles**

Minute Bundles, e.g., Toll Free Minute Bundles, can be purchased in incremental buckets of minute in addition to any number of minutes included with the purchased tier. Inbound Toll Free minutes are deducted from included minutes, purchased Minute Bundles, or charged as overage at the rates currently in effect.

International Calling Credit Bundles can be purchased in addition to any base amount included with the purchased tier. International External Calls are charged against Calling Credits on the Account per destination rates, or as overage once Calling Credits are exceeded. Currently effective rates are available at <https://www.ringcentral.com/support/international-rates.html>.

Extension-to-Extension Calls within the Customer account never incur any usage fee and are unlimited, except to the extent that such calls are forwarded to another number that is not on the Customer account.

Additional Calling Credits may be purchased through the Auto-Purchase feature, which can be selected for automatic purchase in various increments on the Administrative Portal. Auto-Purchase is triggered when the combined usage of all End Users on an Account exceeds the total Calling Credits or when End Users make calls with additional fees (e.g., 411).

Minute Bundles and Calling Credit Bundles expire at the end of month and cannot roll over to the following month. Auto-Purchased Calling Credits expire twelve (12) months from date of purchase. Bundles may not be sold, transferred, assigned, or applied to any other customer.

**3. N11 and other Calling**

**Operator Assisted Calling, 311, 511 and other N11 Calling.** RingCentral does not support 0+ or operator assisted calling (including, without limitation, collect calls, third party billing calls, 900, or calling card calls). The Services may not support 211, 311, 411, 511 and/or N11 calling in one or more service areas. Additional charges may apply for these calls.

**4. Directory Listing Service**

RingCentral offers directory listing (the "Directory Listing Service"). If Customer subscribes to the Directory Listing Service, RingCentral will share certain Customer Contact Data with third parties as reasonably necessary to include in the phone directory ("Listing Information"). This information may include, but is not limited to, Customer's company name, address, and phone numbers. Customer authorizes RingCentral to use and disclose the Listing Information for the purpose of publishing in, and making publicly available through, third-party directory listing services, to be selected by RingCentral or third-party service providers in their sole discretion. Customer acknowledges that by subscribing to the Directory Listing Service, Customer's Listing Information may enter the public domain and that RingCentral cannot control third parties' use of such information obtained through the Directory Listing Service.

**Opt Out.** Customer may opt out of the Directory Listing Service at any time, however RingCentral is not obligated to have Customer's Listing Information removed from third-party directory assistance listing services that have already received Customer's information.

**No Liability.** RingCentral will have no responsibility or liability for any cost, damages, liabilities, or inconvenience caused by calls made to Customer's telephone number; materials sent to Customer, inaccuracies, errors or omissions with Listing Information; or any other use of such information. RingCentral will not be liable to Customer for any use by third parties of Customer's Listing Information obtained through the Directory Listing Service, including without limitation the use of such information after Customer has opted out of the Directory Listing Service.

## 5. RingCentral Global Office

**RingCentral Global Office** provides a single communications system to companies that have offices around the world, offering localized service in countries for which Global Office is available. Additional information related to Global Office Services is available at <http://www.ringcentral.com/legal/policies/global-office-countries.html>.

This section sets forth additional terms and conditions concerning RingCentral's Global Office for customers that subscribe to it.

### A. Emergency Service Limitations for Global Office

RingCentral provides access to Emergency Calling Services in many, but not all, countries in which RingCentral Global Office is available, allowing End Users in most countries to access Emergency Services (911 in the United States and Canada, 999/112 in the United Kingdom and throughout the European Union, and any other applicable Emergency Services number). Emergency Services may only be accessed within the country in which the Digital Line is assigned, e.g., an End User with a Digital Line assigned in Ireland may dial Emergency Services only within Ireland. Access to Emergency Calling Services in RingCentral Global Office countries, where available, is subject to the Emergency Services Policy, available at <https://www.ringcentral.com/legal/emergency-services.html>. Customer must make available and will maintain at all times traditional landline and/or mobile network telephone services that will enable End Users to call the applicable Emergency Services number. Customer may not use the RingCentral Services in environments requiring fail-safe performance or in which the failure of the RingCentral Services could lead directly to death, personal injury, or severe physical or environmental damage.

### B. Global Office Provided Only in Connection with Home Country Service.

RingCentral provides Global Office Service only in connection with Services purchased in the Home Country. RingCentral may immediately suspend or terminate Customer's Global Office Services if Customer terminates its Digital Lines in the Home Country. All invoicing for the Global Office Services will be done in the Home Country on the Customer's Account, together with other Services purchased under this Agreement, using the Home Country's currency. Customer must at all times provide a billing address located in the Home Country. RingCentral will provide all documentation, licenses, and services in connection with the Global Office Service in English; additional language support may be provided at RingCentral's sole discretion.

### C. Relationships with Local Providers.

In connection with the provision of RingCentral Global Office Services, RingCentral relies on local providers to supply certain regulated communication services; for example (i) for the provision of local telephone numbers within local jurisdictions; (ii) to enable you to place local calls within local jurisdictions; and (iii) to enable You to receive calls from non-RingCentral numbers on Customer's Global Office telephone number(s), by connecting with the local public switched telephone network. Customer hereby appoints RingCentral as Customer's agent with power of attorney (and such appointment is coupled with an interest and is irrevocable during the Term) to conclude and enter into agreements with such local providers on Customer's behalf to secure such services.

RingCentral's locally licensed affiliates provide all telecommunications services offered to Customer within the countries in which such affiliates are licensed. RingCentral, Inc., is responsible for all contracting, billing, and customer care related to those services.

## 6. Definitions

**Definitions.** Terms used herein but not otherwise defined have the meanings ascribed to them in the Agreement. For purposes of this Service Attachment, the following terms have the meanings set forth below:

1. **"Digital Line"** means a phone number assigned to an End User or a specifically designated location (e.g., conference room) and the associated voice service for inbound and outbound calling that permits the End User generally to make and receive calls to and from the public switched telephone network as well as to and from other extensions within the same Account.
2. **"End Point"** means an application or device through which any End-User might access and/or use any of the Services, including without limitation IP Desk Phones, Desktop Clients, Web Clients, Mobile Applications, and Software Integrations.
3. **"Extension-to-Extension Calls"** means calls made and received between End Points on the Customer Account with RingCentral, regardless of whether the calls are domestic or international.
4. **"External Calls"** means calls made to or received from external numbers on the PSTN that are not on the Customer Account with RingCentral.
5. **"Home Country"** means the United States or the country that is otherwise designated as Customer's primary or home country in the Order Form.



**SERVICE ATTACHMENT B****Service Attachment – RingCentral Contact Center Services**

This Service Attachment is a part of the Master Services Agreement (the “**Agreement**”) that includes the terms and conditions agreed by the Parties under which RingCentral will provide the RingCentral Contact Center Services to Customer.

In the event of any conflict between the provisions of the Agreement and the provisions of this Service Attachment, such provisions of this Service Attachment will prevail.

**1. Service Overview**

“**RingCentral Contact Center Services**” is a contact center solution consisting of inbound and outbound media routing, queuing, and distribution, and related services, applications, and features, whether included as part of a Subscription Package or ordered separately.

**2. Billing and Payment****A. Billing During the Ramp-Up Period.**

During the Ramp-Up Period, You shall be billed for the Usage and for the Contact Center Services based on the number of Seats as they are actually activated on Your account. Notwithstanding the above, You shall not be billed for any Usage or Contact Center Services for Seats activated solely for use by RingCentral or its subcontractors for the configuration and implementation of Your Contact Center Services. During the Ramp-Up Period, Your Contact Center Services will be limited to five (5) ports. After the Ramp-Up Period, or when total number of CC Contract Seats are activated, whichever happens first, the number of ports will be raised to the contracted amount.

**B. Billing After Ramp-Up Period.**

Starting at the earlier of (i) the end of the Ramp-Up Period or (ii) when the total number of contracted Seats are activated, and until the end of the Term, You agree to pay for: i) the Contact Center Services fees for at least the number of Seats set forth in the Contact Center Services Order (as amended as permitted below) (a “**CC Contract Seat**”) based on the per Seat pricing set forth in the Contact Center Services Order (the “**CC Contract Seat Price**”), as amended from time to time, regardless of the number of Seats being used; ii) any additional fees set forth in the Contact Center Order form.

**C. Adding New Contact Center Contract Seats**

You may add CC Contract Seats at any time either through a new Contact Center Services Order or a written amendment executed by You and RingCentral. The Contact Center Services fees related to these additional CC Contract Seats will be billed at the per Seat price set forth in the Contact Center Order form. For the avoidance of doubt, You will be required to pay for Contact Center Services fees related to these additional CC Contract Seats until the end of the Term.

**D. Adding On-Demand Contact Center Seats**

At any time, You may utilize additional Seats with your Contact Center Services on an as-needed basis (each, an “**On-Demand CC Seat**”). You will be billed for any Contact Center Services at the rate of the CC Contract Seat Price plus twenty dollars (\$20) per month per Seat (the “**On-Demand CC Price**”) until You remove this On-Demand CC Seat from Your Contact Center Services subscription (which You may do at any time in your discretion). Contact Center Services fees for any On-Demand CC Seats will be charged for the full month, regardless of the number of days used. For each monthly billing period, You will be charged for the highest number of On-Demand CC Seats used within such billing period.

**3. Contact Center Services, Settings, and Modifications**

The settings and preferences for your Contact Center Services, including without limitation user rights, user skills, and permissions; routing, points of contact, scripts; registration information; and activation of On-Demand CC Seats, among others, may be set and modified by those individuals whom You allow to have access to the web console (“Account Administrators”). The Customer acknowledges that the acts or omissions of the Account Administrators may result in additional charges or affect the Contact Center Services. The Customer will be solely responsible for the acts or omissions and the impact on billable amounts of the Account Administrators.

**4. Use of Contact Center Services**

You acknowledge and agree that all use of the Contact Center Services shall be subject to this Service Attachment and the Agreement, including without limitation the use policies and data privacy policies in Sections 5 and 9. You acknowledge and agree that You are fully responsible and liable for all use of the Contact Center Services, any software or hardware used in conjunction with the Contact Center Services, and any and all fees and charges that are incurred as a result of such use. Notwithstanding anything to the contrary stated in the Agreement, the use of the Contact Center Services shall be subject to the following terms:

- a. **NO 911 SERVICE. YOU ACKNOWLEDGE AND AGREE THAT 911 / EMERGENCY CALLS OR MESSAGES MAY NOT BE PLACED OR SENT THROUGH THE CONTACT CENTER SERVICES, AND NO 911 CALLING OR SMS OR OTHER MESSAGING SERVICE IS OFFERED OR PROVIDED WITH THE CONTACT CENTER SERVICES. YOU MUST MAKE AVAILABLE ALTERNATIVE ARRANGEMENTS TO PLACE 911 CALLS.**
- b. **Customer 911 Notification Obligations.** You represent, warrant, and covenant that: (i) You shall ensure that any person who might use the Contact Center Services or be present at the physical location where any the Contact Center Services might be accessed or used is fully

informed and aware that he or she will not be able to place calls or send messages to 911 or other emergency response services through the Contact Center Services; and (ii) You shall provide all of the foregoing parties with an alternate method by which to place such calls and, as applicable, to send such messages.

## 5. Definitions

Terms used herein but not otherwise defined have the meanings ascribed to them in the Agreement. For purposes of this Service Attachment, the following terms have the meanings set forth below:

1. "**Contact Center Materials**" means documentation, either electronic or otherwise, that RingCentral provides or makes available to the Customer describing the Contact Center Services, including the components of each Subscription Package, if applicable, and any other features and functionality offered as part of the Contact Center Services. The Contact Center Materials may include without limitation manuals, product descriptions, user or installation instructions, diagrams, printouts, listings, flowcharts and training materials related to the Contact Center Services.
2. "**Contact Center Services Order**" is an Order form executed by the Parties under the terms of the Agreement and this Service Attachment, setting out the details of the subscription to the Contact Center Services, including any Subscription Package, and any additional products, services and functionality purchased by the Customer
3. "**Ramp-Up Period**" is the period of sixty (60) days starting on the Start Date set forth in the Contact Center Services Order Form.
4. "**Seat**" means a license for a single named person to use the Contact Center Services.
5. "**Subscription Package**" is a set of Contact Center Services features and applications, as further defined in the Contact Center Materials, that could be ordered as a bundle.
6. "**Usage**" means any charges incurred in connection with the use of Your Contact Center Services, including, without limitation, local, long-distance, international, and toll-free minutes, charges, ports, and any products listed on the Contact Center Service Order Form.

## SERVICE ATTACHMENT C

### SERVICE ATTACHMENT – RINGCENTRAL PROFESSIONAL SERVICES AGREEMENT

This Service Attachment is a part of the Master Services Agreement (the “**Agreement**”) that includes the terms and conditions agreed by the Parties under which RingCentral will provide the RingCentral Professional Services to Customer.

In the event of any conflict between the provisions of the Agreement and the provisions of this Professional Services Agreement (the “**PS Agreement**”), such provisions of this PS Agreement will prevail.

#### 1. Service Overview

RingCentral shall provide the implementation, installation, consulting, configuration services and other professional services (“**Professional Services**”) as described and agreed upon in writing between the Parties pursuant to a statement of work (“**Statement of Work**” or “**SOW**”).

#### 2. Project Phases

The Professional Services may be delivered in one or more phases. The SOW will specify the milestone, objectives, Sites, fees and other components that are included in the scope of each phase (“**Project Phase**”). The Professional Services may also be provided on a time and material basis (“**T&M Services**”) paid by the hour based on the then current T&M Services hourly rate offered by RingCentral, as specified in the relevant SOW. Customer agrees that the delivery, installation, testing, acceptance and payment for the Professional Services rendered under any one Project Phase is not dependent on the delivery, installation, testing, acceptance and payment for the Professional Services under any other Project Phase. Each Project Phase will be billed upon Acceptance, and payment for each Project Phase is due in full within the applicable payment period agreed between the parties and is non-refundable.

#### 3. Customer Sites and Site Visits

In the event the Parties agree that the Professional Services must be performed at one or more Customer facility(ies) (“**Site(s)**”), the Site(s) will be separately identified in the applicable SOW. Each visit to a separate Customer Site will be considered a separate “**Site Visit**”. When so stipulated in the SOW, each Site may constitute a Project Phase. Customer has the following obligations with respect to all Site Visits:

- a. Customer will maintain and ensure safe working conditions at each Site and shall promptly inform the RingCentral project manager of any known hazardous conditions at any Site prior to any visit by RingCentral Personnel.
- b. Customer shall ensure that all Site hardware and network environment meets or exceed the requirements set forth in the Statement of Work and in “RingCentral VoIP Network Requirements and Recommendations” which can found at: [https://support.ringcentral.com/s/article/9233?language=en\\_US](https://support.ringcentral.com/s/article/9233?language=en_US)
- c. Customer shall provide RingCentral with all reasonable information, cooperation, and assistance that RingCentral requests in connection with performing the Services, including without limitation providing RingCentral with access to Customer’s systems and networks and related system and network administrators. Any failure on the part of Customer to provide the cooperation requested by RingCentral, or to provide the information or hardware and software environment required, may result in the need for a Change Order to contemplate additional fees and extended timelines to accommodate Customer’s failure to do so.
- d. Customer shall ensure that at least ten (10) business days prior to a Site Visit or as otherwise agreed in the applicable SOW, the Customer Project Manager shall provide to the RingCentral Project Manager the following information for the Site to be visited:
  - i. the first and last name, extension number, and email address for delivery of message notification emails of each User for which the Services are to be implemented at the Site and any other information that RingCentral requests to configure the digital lines that are part of such Services to be implemented (this information needs to be in the form of a Microsoft Excel file suitable for use with the Plan Service’s bulk configuration utility);
  - ii. written or illustrated diagrams of Customer’s current and proposed dial plans and data and call flows; and
  - iii. information related to configurations, equipment, and deployment requirements for the Site, as requested by RingCentral.

#### 4. Late Site Visit Change.

The Parties acknowledge and agree that Customer’s cancellation or change of the dates of a Site Visit at any time during the ten (10) business days immediately prior to the date that the Site Visit is scheduled to take place (a “**Late Site Visit Change**”) will cause RingCentral to incur in expenses and losses (including without limitation RingCentral’s costs in rescheduling the Site Visit and/or loss of opportunity for other business during the period during which such Site Visit was to take place). Accordingly, Customer agrees that for each Late Site Visit Change, Customer shall incur (at the time of cancellation or change) and be liable for, as liquidated damages, an amount equal to eight (8) hours of RingCentral T&M Services at RingCentral’s then-current T&M Services hourly rate, as well as any Service Expenses that have already been expended by RingCentral. The Parties acknowledge and agree that this amount is a fair, reasonable, and appropriate pre-estimate of the losses that RingCentral will incur as a result of any single Late Site Visit Change.

#### 5. Professional Services Acceptance

Each SOW will identify the specific criteria required for the completion of each Project Phase (“**Completion Criteria**”). Unless otherwise agreed between the parties in the SOW, upon RingCentral’s completion of the Professional Services for each Project Phase, RingCentral will review the Completion Criteria with Customer and will present to the Customer the Professional Services Project Completion Signoff Form (“**PCF**”) for that Project Phase. Notwithstanding anything to the contrary in this PS Agreement or any SOW, RingCentral’s obligations under any Project Phase are deemed accepted and the Professional Services under such Project Phase shall be considered completed in full and billable upon any of the following (“**Acceptance**”):

- a. Customer executes the PCF.

- b. If RingCentral presents Customer with the PCF and the Customer fails to execute the PCF within three (3) days, unless the Customer provides to RingCentral, within those three (3) days, with a detailed description of the items that are outstanding or that are materially non-conforming with the Completion Criteria applicable to the specific Project Phase. If RingCentral timely receives a rejection notice, then RingCentral will complete or re-perform any portion of the non-conforming Professional Services, and re-submit the PCF for the Project Phase to the Customer for Acceptance as described above. If RingCentral timely receives from the Customer a second rejection notice, and RingCentral, in its reasonable discretion determines that the Professional Services for the Project Phase were properly completed in accordance with the Completion Criteria, the Project Phase will be deemed to have been Accepted.
- c. **Production Use:** Unless otherwise agreed in writing between the parties, production use will constitute Acceptance for all purposes of this PS Agreement.
- d. **T&M Services.** Acceptance for T&M Services, if applicable and used in a SOW, is deemed accepted upon performance.

## 6. Payment

- a. The SOW will set forth the fees that the Customer will pay to RingCentral for each Project Phase, and the rates for T&M Services. Customer will compensate RingCentral fees and expenses for the Services as set forth in the applicable SOW. Customer acknowledges and agrees that all fees and charges shall be due and payable without any deduction, withholding, or offset of any kind, including without limitation for any levy or tax.
- b. **Invoicing and Payment of Professional Services fees.** Except to the extent otherwise provided in a SOW or this Section, all amounts due under this PS Agreement for Professional Services other than T&M Services, shall be invoiced upon Acceptance of each Project Phase. T&M Services will be invoiced Monthly in arrears. The payment term for each invoice is set forth in the Agreement.
- c. **Service Expenses.** In addition to the fees and expenses set forth in the applicable SOW, Customer agrees to reimburse RingCentral for its fixed travel, meal, and lodging expenses incurred in connection with any Site Visit ("**Service Expenses**"). Travel, meal, and lodging expenses shall be invoiced upon Acceptance of each Project phase, alongside all other amounts due under this PS Agreement, on a per-trip/per resource basis.. RingCentral shall, after Customer request, provide information verifying the deployment of on-site resources and expenditure of Service Expenses.
- d. **Additional Fees.** Customer agrees to incur and be liable for any additional fees or other amounts not provided for in this PS Agreement or the applicable SOW. These Additional fees may include, but are not limited to the following:
  - i. For any additional Site Visit(s) not included in the SOW, the Customer agrees to pay on a T&M Services basis, with a minimum fee equal to eight (8) hours of RingCentral per day at the then-current T&M Services hourly rate.

## 7. Changes to SOWs

Changes to any applicable SOW shall be made only in a mutually executed written change order between RingCentral and Customer (a "**Change Order**"), outlining the requested change and the effect of such change on the Services, including without limitation the fees and the timeline as determined by RingCentral in its reasonable discretion. RingCentral shall have no obligation to commence work in connection with any Change Order until the Change Order is agreed upon by both Parties in writing. RingCentral has no obligation to provide any Professional Services outside the scope of an SOW.

## 8. Term and Termination

- a. **Term.** This PS Agreement shall remain in effect for as long as the Agreement is in effect, unless terminated in accordance with this Section.
- b. **Termination.** Either Party may terminate this PS Agreement, in whole or in part, with thirty (30) days' advance written notice to the other Party. Unless otherwise specified in the termination notice, the termination of one SOW or Project Phase shall not necessarily result in the termination of, or otherwise affect, any other SOW or Project Phase.
- c. **Effect of Termination.** In the event that this PS Agreement, a SOW, or a Project Phase is terminated, in whole or in part, for any reason other than for RingCentral's material breach of this PS Agreement, Customer shall be obligated to pay RingCentral for:
  - i. any Professional Services and T&M Services that have been rendered up until the effective date of the termination;
  - ii. all applicable Service Expenses incurred; and
  - iii. (50%) of the fees for any other Professional Services not yet performed, due under the Project Phase(s) being cancelled, if termination of the PS Agreement, SOW, or a Project Phase occurs within one hundred and eighty (180) days of execution. If termination occurs after one hundred and eighty (180) days of execution, Customer shall owe all outstanding fees for any Professional Services not yet performed, due under the Project Phase being cancelled.
- d. **Post-Termination Notice Wrap-Up.** Upon receiving or providing notice of termination of this PS Agreement, RingCentral shall be relieved of and excused from any obligation to continue to perform Services or to perform under any then-current SOWs or Project Phase.

**ATTACHMENT D**

**SERVICE LEVEL AGREEMENT FOR RINGCENTRAL OFFICE SERVICES**

This Service Level Agreement for Office Services (the “Office SLA”) is a part of the Master Services Agreement (the “Agreement”) that includes the Service Availability levels RingCentral commits to deliver on the RingCentral Network for RingCentral Office Services.

**1. Overview**

RingCentral will maintain the following performance levels:

	<b>Performance Level</b>
<b>Voice Services Availability</b> (Monthly Calculation)	99.999%
<b>Quality of Voice Service</b> (Monthly Calculation)	3.8 MOS Score

**2. Minimum Eligibility**

Customer is entitled to the benefits of this Office SLA only to the extent that Customer maintains a minimum of fifty (50) Digital Lines under the Office Service Attachment with a minimum twelve (12) month Term. This Office SLA shall not apply to any period of time where Customer does not meet the foregoing requirements.

**3. Service Delivery Commitments**

**a. Calculation of Service Availability for Voice Services**

Service Availability = [ 1 – ((number of minutes of Down Time x number of Impacted Users) / (total number users x total number of minutes in a calendar month))] x 100

Availability shall be rounded to nearest thousandth of a percent in determining the applicable credit. Service Credits for Down Time will not exceed 30% MRC.

**b. Calculation of Service Credits**

Customer is entitled to the Accelerated Service Credits calculated based on the table below:

**b.1 Accelerated Service Credit Table**

<b>Voice Service Availability</b>	<b>Service Credits</b>
≥ 99.999 %	0% MRC
≥ 99.500 and < 99.999%	5% MRC
≥ 99.000 and < 99.500%	10% MRC
≥ 95.000 and < 99.000%	20% MRC
< 95.000%	30% MRC

**c. No Cumulative Credits**

Where a single incident of Down Time affects Office Services and any other Services provided by RingCentral and covered under a separate service level agreement executed between the parties, resulting in Service Credits under both agreements, Customer is entitled to claim Service Credits under one of the agreements, but not for both.

Service Credits to be paid under this Office SLA will be calculated based Customer's RingCentral Office MRC only and will not include any other fees paid by RingCentral for any other Services, (e.g., Contact Center Services). Service Credits may not exceed the total MRC paid for the relevant Services.

**d. Qualifying for Service Credits.**

Service Credits for Down Time will accrue only to the extent:

- i. Down Time exceeds 1 minute;
- ii. Customer reports the occurrence of Down Time to RingCentral by opening a Support Case and obtaining the corresponding case number within twenty-four (24) hours of the conclusion of the applicable Down Time period;
- iii. RingCentral confirms that the Down Time was the result of an outage or fault on the RingCentral Network; and
- iv. Customer is not in material breach of the Agreement, including its payment obligations.
- v. Customer must submit a written request for Service Credits to RingCentral Customer Service within thirty (30) days of the date the Support Case was opened by Customer, including a short explanation of the credit claimed and the number of the corresponding Support Case;

**4. Quality of Service Commitments**

- a. **Quality of Service Targets.** RingCentral will maintain an average MOS score of 3.8 over each calendar month for Customer Sites in the Territory, except to the extent that Customer endpoints connect via public WiFi, a low bandwidth mobile data connection (3G or lower), or Customer uses of narrowband codecs such as G.729.
- b. **Quality of Service Report:** Customer may request a Quality of Service Report for the preceding calendar month by submitting a Support Case. RingCentral will endeavor to provide the Quality of Service Report within five (5) business days.
- c. **Diagnostic Investigation:** If the Quality of Service Report shows a failure to meet the target 3.8 average MOS as calculated under this Section, RingCentral will use industry-standard diagnostic techniques to investigate the cause of the failure. Customer shall cooperate with RingCentral in this investigation fully and in good faith.
- d. **Diagnostic Remediation.** Based on its investigation, RingCentral will provide a reasonable determination of the root cause(s) of any failure for the quality of service to meet the target MOS of 3.8. RingCentral will resolve any root cause(s) on the RingCentral Network; Customer shall timely implement settings or other resolution advised by RingCentral to improve the quality of service.

**5. Chronic Service Failures**

- a. **Service Availability:** Customer may terminate the Agreement without penalty, and will receive a pro-rata refund of all prepaid, unused fees in the following circumstances if RingCentral fails to meet a Service Availability of at least 99.9% on the RingCentral Network for Voice Services during any three (3) calendar Months in any continuous 6-Month period, and customer has timely reported Down Time as set forth herein.
- b. **Quality of Service:** Customer may terminate the affected Customers Sites under its Agreement without penalty, and will receive a pro-rata refund of all prepaid, unused fees in the following circumstances if RingCentral fails to meet a minimum 3.5 MOS, as measured in duly requested Quality of Service Reports, for the affected Customer Sites within four (4) months of the date of Customer's initial Support Case requesting a Quality of Service Report, except that such right inures only to the extent that Customer has complied fully and in good faith with the cooperation requirements and timely implemented all suggestions from RingCentral, in RingCentral's sole reasonable judgment.
- c. To exercise its termination right under this Office SLA, Customer must deliver written notice of termination to RingCentral no later than ten (10) business days after its right to terminate under this Section accrues.

**6. Sole Remedy**

The remedies available pursuant to this Office SLA (i.e. the issuance of credits and termination for chronic service failure) shall be Customer's sole remedy for any failure to meet committed services levels under this Office SLA.

**7. Definitions**

Terms used herein but not otherwise defined have the meanings ascribed to them in the Agreement. For purposes of this Service Level Agreement, the following terms have the meanings set forth below:

- a) **"Down Time"** is an unscheduled period during which the Voice Services for RingCentral Office on the RingCentral Network are interrupted and not usable, except that Down Time does not include unavailability or interruptions due to (1) acts or omissions of Customer; (2) an event of a Force Majeure; or (3) Customer's breach of the Agreement. Down Time begins to accrue after one (1) minute of unavailability, per incident.
- b) **"Impacted User"** means a user with a Digital Line affected by Down Time. In the event that due to the nature of the incident it is not possible for RingCentral to identify the exact number of users with a Digital affected by Down Time, RingCentral will calculate the Impacted Users on a User-Equivalency basis as defined below.

- c) **“MOS”** means the Mean Opinion Score, determined according to the ITU-T E-model, as approved in June 2015, rounding to the nearest tenth of a percent. MOS provides a prediction of the expected voice quality, as perceived by a typical telephone user, for an end-to-end (i.e. mouth-to-ear) telephone connection under conversational conditions. MOS is measured by RingCentral using network parameters between the Customer endpoint, e.g., the IP Phone or Softphone, and the RingCentral Network, and will accurately reflect quality of the call to the caller using the Voice Services.
- d) **“MRC”** means the monthly recurring subscription charges (excluding taxes, administrative or government mandated fees, metered billings, etc.) owed by Customer to RingCentral for Office Services for the relevant month. If customer is billed other than on a monthly basis, MRC refers to the pro-rata portion of the recurring subscription charges for the relevant calendar month. MRC does not include one-time charges such as phone equipment costs, set-up fees, and similar amounts, nor does it include any charges or fees for services other than Office Services.
- e) **“Quality of Service Report”** means a technical report provided by RingCentral, detailing MOS and related technical information.
- f) **“RingCentral Network”** means the network and supporting facilities between and among the RingCentral points of presence (“PoP(s)”), up to and including the interconnection point between the RingCentral’s network and facilities, and the public Internet, private IP networks, and the PSTN. The RingCentral Network does not include the public Internet, a Customer’s own private network, or the Public Switched Telephone Network (PSTN).
- g) **“Service Availability”** is the time for which Voice Services for RingCentral Office are available on the RingCentral Network, expressed as a percentage of the total time in the relevant calendar month, and calculated as set forth above.
- h) **“Service Credits”** means the amount that RingCentral will credit a Customer’s account pursuant to this Office SLA.
- i) **“Site”** means a physical location in the Territory at which Customer deploys and regularly uses at least five (5) RingCentral Digital Lines. A Digital Line used outside such physical location for a majority of days in the relevant calendar month, such as home offices, virtual offices, or other remote use, will not be included in the line count for this purpose.
- j) **“Support Case”** means an inquiry or incident reported by the Customer, through its helpdesk, to RingCentral’s Customer Care department, by placing a telephone call as outlined at <http://success.ringcentral.com/RCContactSupp>.
- k) **“Territory”** means those countries in which Customers subscribes to RingCentral Office or Global Office Services.
- l) **“User-Equivalency”** means the calculation made by RingCentral to estimate the percentage of the Voice Services impacted by the Down Time. RingCentral may use number of calls, network, device information, vendor and customer reports, and its own technical expertise to make these calculations.
- m) **“Voice Services”** means the audio portion of the Services, across endpoints, including the Softphone, and IP desk phone.



## AIMS Board Meeting Item Cover Letter

Item:

Presented By:

Staff Recommendation:

Committee Approval:

Total Associated Cost:

Included in Budget?

Over or Under Budget?

Amount Over/Under Budget?

Included in LCAP?

Which LCAP?