



Ivy Hill Preparatory Charter School OFFICIAL RECOMMENDATION

IVY HILL PREPARATORY CHARTER SCHOOL Management Recommendation 12-16-19

Recommendation: North Shore Office Supplies

Background:

We received formal proposals from 4 contractors. All contractors did full walk-throughs of the facility and had individual meetings with the Management Team multiple times.

Recommendation:

Management recommends NSOS (North Shore Office Supplies) is hired to complete all 3rd floor renovations for the following reasons.

- NSOS Satisfies our need for an M/WBE certified organization.
- NSOS comes within our budget allocation for capital improvements.
- We currently have a working relationship with NSOS as an established vendor.
- NSOS reviewed all proposals we were presented with to further understand the scope and develop a proposal that not only meets our needs financially but encompasses the vision of management as we extend into Year 2 and beyond.



Date: 12/12/2019

To: IVY HILL PREP CHARTER SCHOOL 475 E 57th St, Brooklyn, NY 11203	Attention to: Mr. Brandon L. Parker Director of Operations
Subject: PROPOSAL- SCOPE OF WORK FOR: IVY HILL PREP 3RD FLOOR	

Dear Brandon,

Thank you for giving us opportunity to submit the proposal to your Educational dynamic institutes. Attached, please find scope of work proposal for IVY HILL PREP 3rd floor. Scope of work breakdown by Trade.

Total Project Cost: \$107,000.00 (One Hundred Seven Thousand Three Hundred Dollars)

Please note all exclusions as stated below and please contact us with further questions and concerns.

Thank you.

Sincerely,

Meghav Parikh
 Director
NSOS INC
Dbas: North Shore Office Supplies
 1804 Plaza Avenue Suite 31
 New Hyde Park, NY 11040
 Tel: (516) 739-1471
 Fax: (516)746-1001
 Email: nitin@nsofficesupplies.com
Https://www.nsofficesupplies.com

Your Procurement Partner

Certified:

- ✓ **New York State Minority Business Enterprise NYS (MBE) ID # 60909**
- ✓ **NYC Department of Education FAMIS vendor number NSO752699**
- ✓ **NYC – Small Business Services Certification ID number: MWCERT 2016-267**

NSOS
North Shore Office Supplies

<p>GENERAL CONDITIONS \$7,200</p> <ul style="list-style-type: none"> • Personal Protection, Tools, and Equipment • Mobilization, Demobilization, and Tools • Dust Protection and Hallway Cleaning • Container Service throughout project 	<p>\$7,200.00</p>
<p>DEMOLITION \$7,700</p> <ul style="list-style-type: none"> • Remove and Discard Surface-Mounted Blackboards from 2nd Floor Classrooms • Remove and Discard Curtain and Curtain Rods from 2nd Floor Classrooms • Remove and Discard Wall Tile from the following areas: <ul style="list-style-type: none"> ○ Girls and Boys Bathroom 2nd Floor ○ Girls and Boys Bathroom 3rd Floor ○ Stairway from 2nd Floor to 3rd Floor Landing ○ Hallway on 3rd Floor 	<p>\$7,700</p>
<p>GENERAL WORK (CONSTRUCTION) \$54,000</p> <ul style="list-style-type: none"> • Skim coat/patch Walls, Post Wall Tile Removal <ul style="list-style-type: none"> ○ Bathroom, Hallway, and Stairway Walls where Tiles were removed • Walls to receive One (1) Coat of Primer and Two (2) Coats of Paint <ul style="list-style-type: none"> ○ Benjamin Moore Regal or Sherwin Williams Promar 200 ○ Rooms Included: 310, 311, 312, 313A, 313B, 315, 316, Bathrooms 2nd and 3rd Floor, ○ Stairway from 2nd floor to 3rd Floor Landing, 3rd Floor Hallway • Paint Hallways includes the following... <ul style="list-style-type: none"> ○ Doors and Trim – total of Twenty-Three (23) ○ Hallway Walls ○ Corkboard Frames – total of Eighteen (18) • Red Floor Tile around Perimeter of 3rd Floor <ul style="list-style-type: none"> ○ Prepare Floor Tile for Paint to remove existing finish ○ Paint Floor Tile • Patch and Paint areas in 206 & 216 <ul style="list-style-type: none"> ○ 206 – area from removing existing cabinets and shelving ○ 216 – area from removing boards • Furnish and Install Corkboard Material onto Hallway Frames 	<p>\$54,000</p>
<p>CABINETRY - \$1,100</p> <ul style="list-style-type: none"> • Remove existing cabinets and reinstall in 3rd Floor Kitchenette 	<p>\$1,100</p>

NSOS
North Shore Office Supplies

<ul style="list-style-type: none"> • Remove shelving from 216 to 206 • Move shelving from 206 to 3rd Floor Kitchenette • Furnish and Install New Cabinet Doors for Existing Millwork in Existing Computer Room <ul style="list-style-type: none"> ○ Light Shellac on Cabinets and Doors 	
FLOORING - \$25,000 <ul style="list-style-type: none"> • Floor Preparation and Patching • Remove and Replace existing VCT Tile w/ Armstrong Standard Excelon VCT <ul style="list-style-type: none"> ○ Rooms included: 310, 311, 312, 313B (according the Client Map), 315 (according to Client Map) • Furnish and Install 4" Rope Rubber Baseboard <ul style="list-style-type: none"> ○ Rooms included: 310, 311, 312, 313A, 313B, 315, 316 	\$25,000
LEARNING BOARDS - \$5,500 <ul style="list-style-type: none"> • Install Nine (9), 4'x8' Surface Mounted Whiteboards <ul style="list-style-type: none"> ○ Whiteboards to be provided by Client • Install Nine (9) Surface Mounted Smartboards as shown in Classrooms on 2nd Floor <ul style="list-style-type: none"> ○ Smartboards to be provided by Client 	\$5,500
BATHROOM ACCESSORIES - \$1,500 <ul style="list-style-type: none"> • Furnish and Install Two (2) Surface Mounted Soap Dispensers – Bobrick Classic Series • Furnish and Install Two (2) Paper Towel Dispensers – Bobrick Classic Series • Furnish and Install Two (2), 16"x24" Bathroom Mirrors with Stainless Steel Channel Frame • Install new locks on all bathroom stalls • Paint Two (2) Bathroom Partitions 	\$1,500
PLUMBING - \$5,300 <ul style="list-style-type: none"> • Remove and Replace Two (2) Water Fountains to Match Existing Fountain on 2nd Floor <ul style="list-style-type: none"> ○ To install on existing roughing 	\$5,300
Total	\$107,000.00

Authorized Signature: 		Authorized Signature:	
Name Print and Title: Meghav Parikh Director NSOS Inc.	Date: 12/12/2019	Name Print and Title: Brandon L. Parker Director of Operations IVY HILL PREP CHARTER SCHOOL	Date: 12/12/2019

RENOVATIONS CONTRACT AGREEMENT

This Renovation Contract Agreement (this "Agreement") is made as of the 2nd day of January, 2020 by NSOS Inc and between Ivy Hill Prep Charter School, a New York corporation located at 475 East 57th Street, Brooklyn, NY 11203 ("IVY Hill Prep Charter School") and Nitin Parikh, NSOS Inc. located at 1804 Plaza Avenue, New Hyde Park, NY 11040. IVY Hill Prep Charter School and NSOS Inc may each be referred to in this Agreement individually as a "Party" and collectively as the "Parties."

The Parties agree as follows:

- 1. Description of Work.** Renovation will be performed at 475 East 57th Street, Brooklyn, NY 11203 (the "Property"), in accordance with agreement made between NSOS Inc & IVY Hill Prep Charter School's contract plans and specifications. Please see Table A and Table B for specifications and payments.

TABLE A - General Construction specifications and payments:

GENERAL CONDITIONS \$7,200 <ul style="list-style-type: none"> • Personal Protection, Tools, and Equipment • Mobilization, Demobilization, and Tools • Dust Protection and Hallway Cleaning • Container Service throughout project 	\$7,200.00
DEMOLITION \$7,700 <ul style="list-style-type: none"> • Remove and Discard Surface-Mounted Blackboards from 2nd Floor Classrooms • Remove and Discard Acoustic Panels from 2nd Floor Classrooms • Remove and Discard Curtain and Curtain Rods from 2nd Floor Classrooms • Remove and Discard Wall Tile from the following areas: <ul style="list-style-type: none"> ○ Girls and Boys Bathroom 2nd Floor ○ Girls and Boys Bathroom 3rd Floor ○ Stairway from 2nd Floor to 3rd Floor Landing ○ Hallway on 3rd Floor 	\$7,700
GENERAL WORK (CONSTRUCTION) \$54,000 <ul style="list-style-type: none"> • Skimcoat/patch Walls, Post Wall Tile Removal <ul style="list-style-type: none"> ○ Bathroom, Hallway, and Stairway Walls where Tiles were removed • Walls to receive One (1) Coat of Primer and Two (2) Coats of Paint <ul style="list-style-type: none"> ○ Benjamin Moore Regal or Sherwin Williams Promar 200 ○ Ceilings to Painted with a White Flat Finish ○ Rooms Included: 310, 311, 312, 313A, 313B, 315, 316, Bathrooms 2nd and 3rd Floor, ○ Stairway from 2nd floor to 3rd Floor Landing, 3rd Floor Hallway • Paint Hallways includes the following... <ul style="list-style-type: none"> ○ Doors and Trim – total of Twenty-Three (23) ○ Hallway Walls ○ Corkboard Frames – total of Eighteen (18) 	\$54,000

<ul style="list-style-type: none"> • Red Floor Tile around Perimeter of 3rd Floor <ul style="list-style-type: none"> ○ Prepare Floor Tile for Paint to remove existing finish ○ Paint Floor Tile • Patch and Paint areas in 206 & 216 <ul style="list-style-type: none"> ○ 206 – area from removing existing cabinets and shelving ○ 216 – area from removing boards • Furnish and Install Corkboard Material onto Hallway Frames 	
CABINETRY - \$1,100 <ul style="list-style-type: none"> • Remove existing cabinets and reinstall in 3rd Floor Kitchenette • Remove shelving from 216 to 206 • Move shelving from 206 to 3rd Floor Kitchenette • Furnish and Install New Cabinet Doors for Existing Millwork in Existing Computer Room <ul style="list-style-type: none"> ○ Light Shellac on Cabinets and Doors 	\$1,100
FLOORING - \$25,000 <ul style="list-style-type: none"> • Floor Preparation and Patching • Remove and Replace existing VCT Tile w/ Armstrong Standard Excelon VCT <ul style="list-style-type: none"> ○ Rooms included: 310, 311, 312, 313B (according the Client Map), 315 (according to Client Map) • Furnish and Install 4” Roppe Rubber Baseboard <ul style="list-style-type: none"> ○ Rooms included: 310, 311, 312, 313A, 313B, 315, 316 	\$25,000
LEARNING BOARDS - \$5,500 <ul style="list-style-type: none"> • Install Nine (9), 4’x8’ Surface Mounted Whiteboards <ul style="list-style-type: none"> ○ Whiteboards to be provided by Client • Install Nine (9) Surface Mounted Smartboards as shown in Classrooms on 2nd Floor <ul style="list-style-type: none"> ○ Smartboards to be provided by Client 	\$5,500
BATHROOM ACCESSORIES - \$1,500 <ul style="list-style-type: none"> • Furnish and Install Two (2) Surface Mounted Soap Dispensers – Bobrick Classic Series • Furnish and Install Two (2) Paper Towel Dispensers – Bobrick Classic Series • Furnish and Install Two (2), 16”x24” Bathroom Mirrors with Stainless Steel Channel Frame • Paint Two (2) Bathroom Partitions 	\$1,500
PLUMBING - \$5,300 <ul style="list-style-type: none"> • Remove and Replace Two (2) Water Fountains to Match Existing Fountain on 2nd Floor <ul style="list-style-type: none"> ○ To install on existing roughing 	\$5,300
Table A: Total	\$107,000.00

TABLE B – Student Locker specifications and payments:

<p>OPTION 3: STACK STUDENT LOCKERS We are pleased to provide you with a quote on the following materials:</p> <ul style="list-style-type: none"> • (200) 15”W x 15”D x 24”H • Each 15”W Locker Door includes <hr/> <p>Each locker per student: \$140.00</p> <p>Stacked Lockers: \$28,000.00</p> <p>Removal, Disposal, Installation of Lockers: \$24,000.00</p>	<p>\$52,000</p>
<p>OPTION 3 : Stack Student Lockers <u>Image Reference and Description:</u> (15”W X 15”D X 24”H)</p> 	
<p>Locker Includes: Hat shelf, one double hook and two single hooks. Single tier. One wide. 16 gauge louvered doors and 24 gauge body. Stainless steel recessed handle, three point gravity lift-type latching. Green guard gold certified. Made from cold rolled sheet steel.</p>	
<p>General Exclusions: Concrete including cutting or chopping of slab, masonry, metals, misc. metals, glass and glazing, in-wall blocking, hoisting, storage, installation of owner provided items, lighting fixtures, electrical, plumbing – sinks, piping and connections and HVAC.</p> <p>General Exclusions and Qualifications:</p> <ol style="list-style-type: none"> 1- We must have free use of the elevator(s) and loading dock. Lack of elevator/dock use may result in additional labor for unloading material. 2- Offload and install price based on open access to elevator for all floors. Base bid does not include any equipment and/or elevator engineer if needed. 	

<p>3- Changes in floor plan, sizes, and/or quantities may result in price change.</p> <p>4- All placed orders are subject to a cancellation charge. ^[L]_[SEP]</p> <p>5- Labor rate is based on non-union, non-prevailing open shop wage rate.</p> <p>6- All labor to be performed during weekdays, between 8AM and 4PM with the exception of Saturday for an extended work period.</p> <p>7- Pricing based on one-time delivery and single handling of materials. Partial, storage re-consignment and/or change in delivery date will result in additional charges. Additional charges will be billed by North Shore Office Supplies Inc. and will require <i>payment/approval</i> prior to material being delivered.</p> <p>8- No retainage after 30 days from <i>acceptance/completion</i> of work.</p> <p>9- Project delays of more than (60) days from the material delivery date listed on contract will result in increase labor and material cost.</p> <p>10- All orders placed are subject to a cancellation fee of up to 30 days.</p> <p>11- This quotation must be signed and returned prior to any orders being placed in production.</p> <p>12- This quotation becomes an integral part of North Shore Office Supplies Inc. contract upon signature.</p>	
<p>* 50% Deposit due at contract signing. * Freight charges are subject to vary based on delivery date. * All prices guaranteed firm for 30-day acceptance. * All orders subject to credit approval. * Delivery promises subject to delays due to strikes, fires, and other causes beyond our control.</p>	
<p><u>Sales Tax</u>: Excluded</p> <p><u>Installation</u>: Included</p> <p><u>Delivery</u>: 8-10 weeks after all approvals</p>	
Table B: Total:	\$52,000.00

2. Contract Price and Payments. IVY Hill Prep Charter School agrees to pay NSOS Inc the total amount of \$107,000.00 and \$52,000.00 (the “Contract Price”). Payment of this amount is subject to additions, accordance with any mutually agreed to changes and/or modifications in the Work. Payment will be made by corporate check, according to the following schedule:

Table A: General Construction

- \$53,500.00 deposit, due upon the execution of this Agreement.
- \$26,750.00 due upon flooring is completed.
- \$13,375.00 due prior to initiation of painting.
- \$13,375 balance due upon notice of completion of work.

Table B: Student Lockers

- \$26,000 balance due upon execution of this Agreement.
- \$13,000 balance due upon notice of delivery of student lockers.
- \$13,000 balance due upon notice of completion of work.

Tentative Time Frame of Completion

- On premise construction will begin the week of March 1st 2020.
- Production Time: 8-10 weeks
- Installation and Completion: 3-4 weeks

3. Notification of Completion. Work under this Agreement shall begin on February 10, 2020. Upon completion of the Work, NSOS Inc shall notify IVY Hill Prep Charter School and IVY Hill Prep Charter School shall make the final payment within thirty (30) days.

4. Materials and Labor. NSOS Inc shall provide labor and equipment, including tools, renovation equipment, machinery, transportation and all other facilities and services, and all materials necessary for the completion of the Work. NSOS Inc may substitute materials, tools of equal caliber and will notify need of change.

5. Supervision of Renovation. NSOS Inc will supervise and direct all renovation under this Agreement.

6. Utilities. IVY Hill Prep Charter School shall pay for all permanent electric, water, phone, cable, sewer and gas service as needed to perform the Work.

7. Right to Stop Work. If IVY Hill Prep Charter School fails to make installment payment, NSOS Inc reserves the right to halt work until the payment is made, or an acceptable change in timeline of payment is revised, all attempts will be made to continue work to completion, otherwise in accordance with contract.

8. NSOS Inc's Insurance. NSOS Inc agrees to maintain at its own expense during the entire period of renovation at the Property:

A. General Liability Insurance. Such general liability insurance as will protect NSOS Inc from claims for property damage and bodily injury, with limits of liability.

9. Waiver of Subrogation. IVY Hill Prep Charter School and NSOS Inc each waive any and all claims or rights to recovery against the other Party for any loss or damage to the extent such loss or damage is covered by insurance or would be covered by any insurance required under this Agreement.

10. Extension of Time. The times stated in this Agreement may be extended for such reasonable time as NSOS Inc may determine when performance of the Work by NSOS Inc is delayed by a Change Order, labor disputes, fire,

unusual delay in deliveries, abnormal adverse weather conditions, unavoidable casualties, or other causes beyond NSOS Inc's control or which justify the delay.

11. Disputes. Any dispute arising from this Agreement shall be resolved through mediation. If the dispute cannot be resolved through mediation, then the dispute will be resolved through binding arbitration conducted in accordance with the rules of the American Arbitration Association.

12. Binding Effect. This Agreement shall be binding and ensure to the benefit of the Parties and their respective legal representatives, heirs, administrators, executors, successors and permitted assigns.

13. Amendments. This Agreement may not be amended or modified except by a written agreement signed by the all of the Parties.

IN WITNESS WHEREOF, the Parties have executed this Agreement as of the date _____.

Mr. Brandon L. Parker	Director of Operations	
IVY Hill Prep Charter School Representative Name	IVY Hill Prep Charter School Representative Title	IVY Hill Prep Charter School Representative Signature
Mr. Nitin C. Parikh	Chief Executive Officer	N.C.Parikh
NSOS Inc Representative Name	NSOS Inc Representative Title	NSOS Inc Representative Signature



Date: 1/17/2020

To: IVY HILL PREP CHARTER SCHOOL 475 E 57th St, Brooklyn, NY 11203	Attention to: Mr. Brandon L. Parker Director of Operations
Subject: PROPOSAL - School Lockers	

Dear Brandon,

We have provided 3 proposal options for the student lockers. Please review and consider all options presented. If there is another way that we can accommodate, please let us know.

Option 1 are the current lockers that you have in place. As you know these lockers are no longer manufactured, so it is now a custom item. We have contacted multiple companies/manufacturers and there are only 2 manufacturers within the U.S. that have the capability to custom make these sizes. This customization significantly drives up the cost of welding and production process. Thus, we do not recommend this option, however we have listed it here for your preference.

Option 2 & 3 are industry standard lockers, and the pricing structure is reflective of the availability. Both these options are very popular with our clients. We recommend you take look at the details of each option and let us know what suits your institution the best.

If Option 1 is a must, we are awaiting a quote from an overseas manufacturer, which may reduce the cost.

Thank you for giving us opportunity to submit the proposal to your Educational dynamic institutes.

Attached, please find the proposals for each option.

Sincerely,

Meghav Parikh
 Director
North Shore Office Supplies
 1804 Plaza Avenue Suite 31
 New Hyde Park, NY 11040
 Tel: (516) 739-1471
 Email: nitin@nsofficesupplies.com
<https://www.nsofficesupplies.com>

OPTION 1: Customized Student locker

We are pleased to provide you with a quote on the following materials:

- (100) 15"W x 12"D x 48"H All-Welded Corridor Lockers
- Each 15"W Locker Door includes (2) 7.5" Doors
- This quote excludes locks, bases, sloped tops, fillers

Student Locker (200): \$169,000.00

Each locker: \$845.00

Image Reference: (15"D X 15" W X 48"H)

These are the customized lockers to match what is in place now.



OPTION 2: Split Student Locker

We are pleased to provide you with a quote on the following materials:

- (100) 15"W x 15"D x 48"H
- Each 15"W Locker Door includes double sided-hooks

Split Lockers: \$17,000.00

Each locker: \$170

Possible to use as a shared locker system.

For Image Reference: Please see green locker



Locker Includes: 3-point gravity latch closure, just like standard school lockers. Hat shelf and coat hooks included (1 double and 2 single hooks). Recessed handle accepts master locks. 16 gauge louvered doors and 24 gauge body. Continuous Piano-hinge on right side of door.

OPTION 3: Stack Student Lockers

We are pleased to provide you with a quote on the following materials:

- (200) 15”W x 15”D x 24”H
- Each 15”W Locker Door includes

Stacked Lockers: \$28,000.00

Each locker per student: \$140.00

Image Reference and Description: (15”W X 15”D X 24”H)



Locker Includes: Hat shelf, one double hook and two single hooks. Single tier. One wide. 16 gauge louvered doors and 24 gauge body. Stainless steel recessed handle, three point gravity lift-type latching. Green guard gold certified. Made from cold rolled sheet steel.



Removal, Disposal, Installation of Lockers: \$24,000.00

General Exclusions: Concrete including cutting or chopping of slab, masonry, metals, misc. metals, glass and glazing, in-wall blocking, hoisting, storage, installation of owner provided items, lighting fixtures, electrical, plumbing – sinks, piping and connections and HVAC

General Exclusions and Qualifications:

- 1- We must have free use of the elevator(s) and loading dock. Lack of elevator/dock use may result in additional labor for unloading material.
- 2- Offload and install price based on open access to elevator for all floors. Base bid does not include any equipment and/or elevator engineer if needed. [SEP]
- 3- Changes in floor plan, sizes, and/or quantities may result in price change.
- 4- All placed orders are subject to a cancellation charge. [SEP]
- 5- Labor rate is based on non-union, non-prevailing open shop wage rate.
- 6- All labor to be performed during weekdays, between 8AM and 4PM with the exception of Saturday for an extended work period.
- 7- Pricing based on one-time delivery and single handling of materials. Partial, storage re-consignment and/or change in delivery date will result in additional charges. Additional charges will be billed by North Shore Office Supplies Inc. and will require *payment/approval* prior to material being delivered.
- 8- No retainage after 30 days from *acceptance/completion* of work.
- 9- Project delays of more than (60) days from the material delivery date listed on contract will result in increase labor and material cost.
- 10- All orders placed are subject to a cancellation fee of up to 30 days.
- 11- This quotation must be signed and returned prior to any orders being placed in production.
- 12- This quotation becomes an integral part of North Shore Office Supplies Inc. contract upon signature.

* 50% Deposit due at contract signing.

*All prices guaranteed firm for 30-day acceptance.

*All orders subject to credit approval.

*Delivery promises subject to delays due to strikes, fires, and other causes beyond our control.

Sales Tax: Excluded

Delivery: Included

Installation: Included

Delivery: 6-8 weeks after all approvals



Proposal Agreement

<p>Please Select from the following:</p>	<p>Add Suggestions/Additions/Modifications Below:</p>
<p> <input type="radio"/> OPTION 1: Customized Student Locker <input type="radio"/> OPTION 2: Split Student Locker <input type="radio"/> OPTION 3: Stack Student Locker </p>	
<p>Authorized Signature:</p>	<p>Authorized Signature:</p>
<p> Name Print and Title: Date: Meghav Parikh 1/17/2020 Director NSOS Inc. </p>	<p> Name Print and Title: Date: Brandon L. Parker 1/17/2020 Director of Operations IVY HILL PREP CHARTER SCHOOL </p>

License # 2088507

Licensed, Insured & Bonded

Estimate

Reference 1202777
Date 10th October 2019



To Ivy Hill Prep
475 East 57th Street
Brooklyn, New York
11203

Tel: 646 450 3637
Email: extramileconstr@gmail.com

For 475 East 57th Street
Brooklyn, New York
11203

Dear Ambrosia Johnson,
Thank you for asking us to look at your project for the third floor, here's our estimate for the work. If you've got any questions or we can help with anything else, please just get in touch. We'd be very happy to help.

Painting - classrooms, staircase and bathrooms labour \$12,600

Locker removals \$1,600

Removal of Tiles from walls, Skim-coat walls, removal of tiling from (1) classroom floor \$8,400

Materials \$5,400

Total: \$28,000.00

Yours sincerely

Shameka Johnson



SPROUT.

A PROPOSAL TO: IVY HILL PREP CHARTER SCHOOL

NOVEMBER 21, 2019



WHO WE ARE

BUILD SPROUT

Build Green. Build Smart.

Sprout innovates, stretches your dollars and strives to build using 'green' construction philosophies. Our sustainably focused, yet attractive renovation and construction projects are welcoming places to work, live and learn.

We know that every facet of your project is important. Each detail impacts your day to day experience and we want to be sure you enjoy it.

OUR MISSION

To bring our clients and their stakeholders the best value, by understanding their goals and delivering spaces that are...

- **Innovative**
- **Environmentally Friendly**
- **Economical to Operate**

This is our approach to development, construction, and renovation.

SPROUT, LLC DBA BUILD SPROUT, LLC is a Delaware based limited liability company with authority to conduct business in the State of New York. SPROUT, LLC DBA BUILD SPROUT, LLC is a licensed General Contractor with the City of New York.

LEADERSHIP

ALEX R. JEREZ, FOUNDER

Alex worked for Hines Interests L.P., the largest, privately-held real estate company in the world and a forerunner in bringing sustainability to real estate. The Harvard University graduate has also worked in international real estate finance, and as a property manager for UBS Tower, a Class A office building in Chicago's West Loop. Prior to founding Sprout he served as the former founding director of operations for Children's Aid College Prep Charter School in the Bronx.

CHRISTIAN GUERRERO, PRESIDENT

Christian served as Vice President for two years, prior to his promotion. He provides leadership and oversight on the day-to-day operations for all Construction, Project Management and Project Administration activities associated with the company's commercial and residential projects. Prior to joining Sprout, he served as the co-founder of Inwood Academy for Leadership Charter School in Manhattan.

RICHARD CAMAANO, ADMIN. ASSISTANT

Richard serves as our Administrative Assistant overseeing the logistics between the back-office and field operations. At Sprout he utilizes his skills to ensure and improve the performance, productivity, and efficiency of our construction projects.



IVY HILL PREP CHARTER SCHOOL

Please accept the project bid below as requested by Brandon Parker, Director of Operations. Please note all exclusions as stated below and please contact us with further questions and concerns.

Total Project Cost: \$107,300.00
(One Hundred and Seven Thousand, Three Hundred Dollars)

Scope of Work – Breakdown by Trade

NOTE: Project bid on regular time Monday – Friday 8 am – 5pm.

GENERAL CONDITIONS - \$7,200

- Personal Protection, Tools, and Equipment
- Mobilization, Demobilization, and Tools
- Dust Protection and Hallway Cleaning
- Container Service throughout project

DEMOLITION - \$7,700

- Remove and Discard Surface-Mounted Blackboards from 2nd Floor Classrooms
- Remove and Discard Acoustic Panels from 2nd Floor Classrooms
- Remove and Discard Curtain and Curtain Rods from 2nd Floor Classrooms
- Remove and Discard Wall Tile from the following areas:
 - Girls and Boys Bathroom 2nd Floor
 - Girls and Boys Bathroom 3rd Floor
 - Stairway from 2nd Floor to 3rd Floor Landing
 - Hallway on 3rd Floor

GENERAL WORK (CONSTRUCTION) - \$54,000

- Skimcoat/patch Walls, Post Wall Tile Removal
 - Bathroom, Hallway, and Stairway Walls where Tiles were removed
- Walls to receive One (1) Coat of Primer and Two (2) Coats of Paint
 - Benjamin Moore Regal or Sherwin Williams Promar 200
 - Ceilings to Painted with a White Flat Finish
 - Rooms Included: 310, 311, 312, 313A, 313B, 315, 316, Bathrooms 2nd and 3rd Floor, Stairway from 2nd floor to 3rd Floor Landing, 3rd Floor Hallway
- Paint Hallways includes the following...
 - Doors and Trim – total of Twenty-Three (23)
 - Hallway Walls
 - Corkboard Frames – total of Eighteen (18)
- Red Floor Tile around Perimeter of 3rd Floor
 - Prepare Floor Tile for Paint to remove existing finish
 - Paint Floor Tile



IVY HILL PREP CHARTER SCHOOL

- Patch and Paint areas in 206 & 216
 - 206 – area from removing existing cabinets and shelving
 - 216 – area from removing boards
- Furnish and Install Corkboard Material onto Hallway Frames

CABINETS - \$1,100

- Remove existing cabinets and reinstall in 3rd Floor Kitchenette
- Remove shelving from 216 to 206
- Move shelving from 206 to 3rd Floor Kitchenette
- Furnish and Install New Cabinet Doors for Existing Millwork in Existing Computer Room
 - Light Shellac on Cabinets and Doors

FLOORING - \$25,000

- Floor Preparation and Patching
- Remove and Replace existing VCT Tile w/ Armstrong Standard Excelon VCT
 - Rooms included: 310, 311, 312, 313B (according the Client Map), 315 (according to Client Map)
- Furnish and Install 4" Roppe Rubber Baseboard
 - Rooms included: 310, 311, 312, 313A, 313B, 315, 316

LEARNING BOARDS - \$5,500

- Install Nine (9), 4'x8' Surface Mounted Whiteboards
 - *Whiteboards to be provided by Client*
- Install Nine (9) Surface Mounted Smartboards as shown in Classrooms on 2nd Floor
 - *Smartboards to be provided by Client*

BATHROOM ACCESSORIES - \$1,500

- Furnish and Install Two (2) Surface Mounted Soap Dispensers – Bobrick Classic Series
- Furnish and Install Two (2) Paper Towel Dispensers – Bobrick Classic Series
- Furnish and Install Two (2), 16"x24" Bathroom Mirrors with Stainless Steel Channel Frame
- Paint Two (2) Bathroom Partitions

PLUMBING - \$5,300

- Remove and Replace Two (2) Water Fountains to Match Existing Fountain on 2nd Floor
 - To install on existing roughing

EXCLUDED FROM TOTAL PRICE

ALTERNATE – LOCKERS - \$23,650

- Furnish and Install Thirty-One Units (31), equaling 186 Lockers. It includes the following items...
 - Sloped Top and Kickplate – to prevent unwanted storage and debris on top & bottom of unit
 - Freight, Receipt of Delivery, Assembly and Installation
- Remove and Discard Existing Lockers
- Patch and Paint as Needed





197 S. BROADWAY
YONKERS, NY 10705
www.buildsprout.com

E: admin@buildsprout.com
O: (718) 490-7493
F: (718) 713-1820



Matter Real Estate

Proposal for Renovation of Existing Space

Ivy Hill Preparatory Charter School

MATTER REAL ESTATE

Brandon Parker, Director of Operations
Ivy Hill Preparatory Charter School
475 E. 57th Street
Brooklyn, NY 11203
(917) 789-8959

November 21, 2019

Dear Brandon:

Thank you giving us the opportunity to provide a proposal for the renovation of your school located at 475 E. 57th Street. After completing multiple walkthroughs and carefully reviewing the project's scope of work with AC Interior Group, we are providing you with a quote to complete the project for a **total sum of \$369,570**. Please note that the cost of two person lockers has been included and a credit of \$11,920 will be issued if double tier lockers are chosen. Enclosed, you will find an itemized scope of work, an estimate for the listed work and an alternate estimate for 3rd floor toilet partitions and cut-sheets for equipment.

Matter real estate is a boutique firm providing advisory, project management and owner's representative services to not-for-profits, universities, and commercial developers. Our track record highlights the success I've had helping organizations like Ivy Hill Prep build great spaces that are functional, safe, and economical. We are proud to have worked with clients including Goodwill NY/NJ, Seton Education Partners/Brilla Charter Schools, Academy of the City, and many others.

Please call me to discuss any questions or comments you may have. Thank you again for the opportunity to work with Ivy Hill Prep on this project.

Sincerely,



Principal, Matter Real Estate



Pending: asbestos report

Floor #2 Renovation Scope

Girls Bathroom

- Replace (2) mirrors
- Piping under the sink to be enclosed (stainless steel)

Boys Bathroom

- Replace (2) mirrors
- Piping under the sink to be enclosed (stainless steel)

Room 206

- Remove existing cabinets and reinstall in 3rd floor kitchen - confirmed
- Room to become a book room (Move shelves from 216)
- Move copy machines from 216 (Install proper electrical outlets)

Room 216

- Replace A/C and move to top window sash
- Move shelving to room 206

Floor #3 Renovation Scope

Girls Bathroom

- Replace mirrors
- Keep existing flooring
- Keep partitions and paint or replace partitions – alternate estimate provided (Exhibit B)
- Replace sinks
- Piping under the sink to be enclosed (stainless steel)
- Paint walls and ceiling
- Repaint entrance hallway to remove paintings
- Paint ceiling ductwork (Paint to match)

Boys Bathroom

- Replace mirrors
- Change bathroom door hardware
- Keep existing flooring
- Keep partitions and paint or replace partitions – alternate estimate provided (Exhibit B)
- Replace sinks
- Piping under the sink to be enclosed (stainless steel)
- Paint walls and ceiling
- Repaint entrance hallway to remove paintings
- Paint ceiling ductwork (Paint to match)

Room 310 - Side Rooms (Function TBD)

- Remove existing boards & repair walls
- Replace A/C & move to top sash
- Test pipe insulation for asbestos
- Replace flooring
- Paint ceiling / walls / doors / frames / radiators

Room 310

- Install Smartboards
- Replace A/C & move to top sash
- Repair flooring (Do not remove)
- Repaint ceiling / walls / doors / frames / radiators
- (Smart boards are stored in this room)
 - Half repurposed and half are new
 - School will go through hardware to confirm complete installation kits

Room 311

- Install Smartboards
- Replace A/C & move to top sash
- Replace flooring
- Repaint ceiling / walls / doors / frames / radiators
- (Small space to be treated as a pull-out room)
 - Remove items on walls
 - Repaint ceiling / walls / doors / frames / radiators
 - Replace flooring to match room 311

Room 312

- Install Smartboards
- Replace A/C & move to top sash
- Replace flooring
- Repaint ceiling / walls / doors / frames / radiators

Room 313A

- Install Smartboards
- Replace A/C & move to top sash
- Replace flooring
- Repaint ceiling / walls / doors / frames / radiators

Room 313B

- Install Smartboards
- Replace A/C & move to top sash
- Replace flooring
- Repaint ceiling / walls / doors / frames / radiators

Room 313 - DOO (Function TBD)

- Remove A/C (Keep electrical for future A/C)
- Remove carpet & replace flooring
- Repaint ceiling / walls / doors / frames / radiators

Room 313 - Kitchen

- Remove old cabinets
- Move 2nd floor kitchen cabinets to 3rd floor
- Remove shelving & items from walls
- Repaint ceiling / walls / doors / frames / radiators
- Install new outlets for kitchen appliances
- **Asbestos tile testing?**

Room 314

- Install Smartboards
- Replace A/C & move to top sash
- Replace flooring
- Repaint ceiling / walls / doors / frames / radiators

Room 315

- Install Smartboards
- Replace A/C & move to top sash (Remove 1 A/C)
- Repaint ceiling / walls / doors / frames
- Repaint lab table legs
- Repair and repaint cabinet doors

Room 316

- Install Smartboards
- Replace A/C & move to top sash
- Replace flooring
- Repaint ceiling / walls / doors / frames / radiator
- **Asbestos tile testing?**

Room 318

- Install Smartboards
- Replace A/C & move to top sash (Remove extra A/C)
- Repaint ceiling / walls / doors / frames/ radiators
- **Asbestos tile testing?**

Stairway A

- Remove existing chair rail tile
- Paint front of steps
- Paint cast iron railings
- Paint stairwells

Hallways

- Remove existing chair rail wall tiles
- Replace existing lockers with new equivalent two person lockers
- Repaint hallway, doors, door frames, elevator door, lockers
 - Paint over red trim floor tiles
- Replace corkboard base & paint frames
- Replace 3 exit signs
- Install 2 new water fountains w/ bottle filler

MATTER REAL ESTATE

We appreciate the opportunity to submit this proposal and look forward to working with you on this exciting project. If the terms and conditions set forth above are acceptable, please sign, date and return a copy of the proposal.

ACCEPTED AND AGREED:

By: _____ Date: _____

Authorized Signatory
Ivy Hill Preparatory Charter School



Exhibits

Exhibit A: Project Estimate

AC Interior Group
 30 Wall Street, 8th Floor
 New York, NY 10005 US
 (212) 796-4390
 info@acinteriorgroup.com
 http://www.acinteriorgroup.com



Estimate 20192459

ADDRESS Ivy Hill Prep 475 East 57th Street Brooklyn, NY 11203	DATE 11/12/2019	TOTAL \$329,570.00	

ACTIVITY	QTY	RATE	AMOUNT
Bathroom Renovation 2nd Floor Boys Bathroom • Replace (2) mirrors \$650.00 • Piping under the sink to be enclosed \$1500.00 stainless steel	1	2,150.00	2,150.00
Bathroom Renovation 2nd Floor Girls Bathroom • Replace (2) mirrors \$650.00 • Piping under the sink to be enclosed \$2500.00 stainless steel	1	3,150.00	3,150.00
Bathroom Renovation 3rd Floor Girls Bathroom • Replace (2) mirrors \$650.00 • Keep existing flooring • Remove existing sinks • Supply and install 2 wall mount sink & metering faucets \$4800.00 • Piping under the sink to be enclosed \$2500.00 stainless steel • Paint walls and ceiling \$2000.00 • Repaint entrance hallway to remove paintings • Paint ceiling ductwork (Paint to match)	1	9,950.00	9,950.00
Bathroom Renovation 3rd Floor Boys Bathroom • Replace (2) mirrors \$650.00 • Keep existing flooring • Remove existing sink • Supply and install 1 wall mount sink & metering faucet \$2400.00 • Piping under the sink to be enclosed \$1500.00 stainless steel • Paint walls and ceiling \$2000.00 • Repaint entrance hallway to remove paintings • Paint ceiling ductwork (Paint to match)	1	6,550.00	6,550.00
General Construction 3rd floor Hallway • Remove existing chair rail wall tiles (around door frames x13) \$19,500.00 • Repaint hallway walls, doors, door frames, elevator door, \$7500.00 • Replace corkboard base & paint frames (12) \$9600.00 • Replace 3 exit signs (included in electric scope) • Install 2 new water fountains w/ bottle filler \$3500 x 2 = \$7000.00	1	43,600.00	43,600.00
General Construction Room 206 • Remove existing cabinets and reinstall in 3rd floor kitchen \$500.00 • Room to become a book room (Move shelves from 216) \$500.00 • Move copy machines from 216 (included in electric scope)	1	1,000.00	1,000.00
General Construction Room 216 • Replace A/C and move to top window sash \$4000.00 w/ new ritter kit • Move shelving to room 206 \$500.00	1	4,500.00	4,500.00
General Construction Room 310 - Side Rooms (Function TBD) • Remove existing boards & repair walls \$750.00 • Replace A/C & move to top sash \$4000.00 w/ new ritter kit • Replace flooring (included in flooring cost below) • Paint ceiling / walls / doors / frames / radiators \$2000.00	1	6,750.00	6,750.00

ACTIVITY	QTY	RATE	AMOUNT
General Construction Room 310 • Install Smartboards \$1500.00 (Install, new cables, raceways & connectors with HDMI box / cable management & focus/setup) • Replace A/C & move to top sash \$4000.00 w/ new ritter kit • Repair flooring (Do not remove) • Repaint ceiling / walls / doors / frames / radiators \$5000.00 (Smart boards are stored in this room) o Half repurposed and half are new o School will go through hardware to confirm complete installation kits	1	10,500.00	10,500.00
General Construction Room 311 • Install Smartboards \$1500.00 (Install, new cables, raceways & connectors with HDMI box / cable management & focus/setup) • Replace A/C & move to top sash \$4000.00 w/ new ritter kit • Replace flooring • Repaint ceiling / walls / doors / frames / radiators \$4000.00 (Small space to be treated as a pull-out room)	1	9,500.00	9,500.00
General Construction Room 312 • Install Smartboards \$1500.00 (Install, new cables, raceways & connectors with HDMI box / cable management & focus/setup) • Replace A/C & move to top sash \$4000.00 w/ new ritter kit • Replace flooring • Repaint ceiling / walls / doors / frames / radiators \$4000.00	1	9,500.00	9,500.00
General Construction Room 313A • Install Smartboards \$1500.00 (Install, new cables, raceways & connectors with HDMI box / cable management & focus/setup) • New whiteboards / corkboards 2 - 4 x 8 corkboards \$1000.00 & 2 - 4 x 8 whiteboards \$2400.00 • Replace A/C & move to top sash \$4000.00 w/ new ritter kit • Replace flooring • Repaint ceiling / walls / doors / frames / radiators \$2500.00	1	11,400.00	11,400.00
General Construction Room 313B • Install Smartboards \$1500.00 (Install, new cables, raceways & connectors with HDMI box / cable management & focus/setup) • Replace A/C & move to top sash \$4000.00 w/ new ritter kit • Replace flooring • Repaint ceiling / walls / doors / frames / radiators \$3500.00	1	9,000.00	9,000.00
General Construction Room 313 - DOO (Function TBD) • Remove A/C (Keep electrical for future A/C) \$250.00 for removal/dispose • Remove carpet & replace flooring • Repaint ceiling / walls / doors / frames / radiators \$2000.00	1	2,250.00	2,250.00
General Construction Room 313 - Kitchen • Remove old cabinets \$500.00 • Move 2nd floor kitchen cabinets to 3rd floor \$1500.00 • Remove shelving & items from walls \$250.00 • Repaint ceiling / walls / doors / frames / radiators \$2000.00	1	4,250.00	4,250.00
General Construction Room 314 • Install Smartboards \$1500.00 (Install, new cables, raceways & connectors with HDMI box / cable management & focus/setup) • Replace A/C & move to top sash \$4000.00 w/ new ritter kit • Replace flooring • Repaint ceiling / walls / doors / frames / radiators \$3500.00	1	9,000.00	9,000.00
General Construction Room 315 • Install Smartboards \$1500.00 (Install, new cables, raceways & connectors with HDMI box / cable management & focus/setup) • Replace A/C & move to top sash (Remove 1 A/C) \$4000.00 w/ new ritter kit • Repaint ceiling / walls / doors / frames \$3500.00 • Repaint lab table legs \$250.00 • Replace and paint 7 cabinet doors 2800.00	1	12,050.00	12,050.00
General Construction Room 316 • Install Smartboards \$1500.00 (Install, new cables, raceways & connectors with HDMI box / cable management & focus/setup) • Replace A/C & move to top sash \$4000.00 w/ new ritter kit • Replace flooring • Repaint ceiling / walls / doors / frames / radiator \$3500.00	1	9,000.00	9,000.00
General Construction Room 318 • Install Smartboards \$1500.00 (Install, new cables, raceways & connectors with HDMI box / cable management & focus/setup) • Replace A/C & move to top sash (Remove extra A/C) \$4000.00 w/ new ritter kit • Repaint ceiling / walls / doors / frames/ radiators \$3500.00	1	9,000.00	9,000.00

ACTIVITY	QTY	RATE	AMOUNT
Painting Stairway A • Remove existing chair rail tile • Paint front of steps • Paint cast iron railings • Paint stairwells	1	10,500.00	10,500.00
Electric Rooms 216, 310,311, 312, 313A, 313B, 314, 315, 316, 318 Relocate existing AC receptacle and install switch outlet 3rd Floor Water coolers- correct defective wiring for new water coolers. Install GFI receptacle for new water cooler. 3rd Floor Supply and install 3 Exit signs with battery back -up at existing locations Kitchen Supply and install 1 /115volt 20amp circuit for refrigerator 1 /115volt 20amp circuit for Microwave 1 /115volt 20amp circuit for Duplex receptacle on counter	1	24,600.00	24,600.00
Flooring Room 310 ,311,312,313,313A,313B,314,315,316,318 Smooth coat floors. Supply and install VCT tiles Supply and install cove base	1	59,600.00	59,600.00
Paint Epoxy paint floor tiles in 1 hallway. Prepare and paint all red floor tiles around hallway perimeter.	1	3,200.00	3,200.00
AV Tech Support \$200.00 per hour, 1 hour minium. Technician to sort and inventory all projectors and parts. Create list of missing parts to complete installations, if needed. Any time not used will be credited back. Budget 4 hours.	4	200.00	800.00
Lockers Supply and new 2 person locker (226 lockers/doors)	1	57,770.00	57,770.00
Lockers credit If double tier lockers are chosen, deduct \$11,920.00	0	11,920.00	0.00

TOTAL

\$329,570.00

THANK YOU.

Accepted By

Accepted Date

Exhibit B: Toilet Partition Estimate



AC Interior Group
 30 Wall Street, 8th Floor
 New York, NY 10005 US
 (212) 796-4390
 info@acinteriorgroup.com
 http://www.acinteriorgroup.com



Estimate 20192451

ADDRESS	DATE	TOTAL
Ivy Hill Prep 475 East 57th Street Brooklyn, NY 11203	11/11/2019	\$0.00

ACTIVITY	QTY	RATE	AMOUNT
Bathroom Renovation • 3rd floor girls bathroom Keep partitions and paint (fix hardware) \$2400.00 paint, \$500.00 repairs	0	2,900.00	0.00
Bathroom Renovation • 3rd floor boys bathroom Keep partitions and paint (fix hardware) \$1600.00 paint, \$500.00 repairs	0	2,100.00	0.00
Partitions 3rd floor Bathroom Partitions Remove existing partitions Supply and install (3) Toilet Compartments Supply and install (3) new toilet paper dispensers, by Bobrick. Type: Solid Plastic-Standard, Floor Mounted Overhead Braced Features: Standard height, Stirrup brackets, Standard color Elevator usage is mandatory for distribution of material. If elevator is unavailable, Additional costs will be incurred. These added costs will be determined based on job Site conditions.	0	9,550.00	0.00

TOTAL \$0.00

THANK YOU.

Accepted By

Accepted Date

Exhibit C: Equipment Cut Sheets



COLOR SELECTION FORM

Please select a color below. Note: for multi-colored orders, please annotate the color / texture on submittal drawings.

Standard lead times apply

Standard Color Choices

Classic Color Collection

Orange Peel Texture	
Black	
Blueberry	
Burgundy	
Charcoal Grey	
Desert Beige	
Fossil	
Grey	
Hunter Green	
Linen	
Mocha	
White	
French Blue	

EX Texture	
Black	
Desert Beige*	

Metallic Color Collection

Hammered Texture	
Stainless	
Bronze	
Nickel	
Rotary Brushed Texture	
Stainless	
Bronze	
Nickel	
EX Texture	
Stainless	

Mosaic Color Collection

Orange Peel Texture	
Bluestone*	
Glacier Grey	
Gravel*	
Onyx*	
Paisley	
Sandcastle	
Sandstone	
Storm*	

Designer Color Collection

Orange Peel Texture	
Mahogany	
Shale	
Concrete	

Fire Rated Color Choices

Fire Rated Materials

Class B

Orange Peel Texture	
Black	
Blueberry	
Paisley	
Desert Beige	
Linen	
Mocha	
Grey	
Charcoal Grey	
White	

Hammered Texture

Stainless	
Bronze	
Nickel	

Fire Rated Materials

Class A, NFPA 286

Orange Peel Texture	
Black	
Blueberry	
Paisley	
Desert Beige	
Linen	
Mocha	
White	

Hardware Options

Continuous Plastic

Brackets / Shoes

Black	
Blueberry	
Desert Beige	
Grey	
Linen	
Mocha	

Bracket Types

Plastic (specify color above)
Stainless Steel Stirrup
Aluminum Stirrup
**Continuous Stainless Steel
**Continuous Aluminum

**Upcharges Apply

Shoes

Plastic (specify color above)
Stainless Steel



AMERICAN SPECIALTIES, INC.
 441 Saw Mill River Road, NY 10701
 (914) 476.9000 • (914) 476.0688
 www.americanspecialties.com

MODEL No: 0535

ISSUED: 01/87

REVISED: 19 FEB 2018

FIXED ANGLE TILTED MIRROR

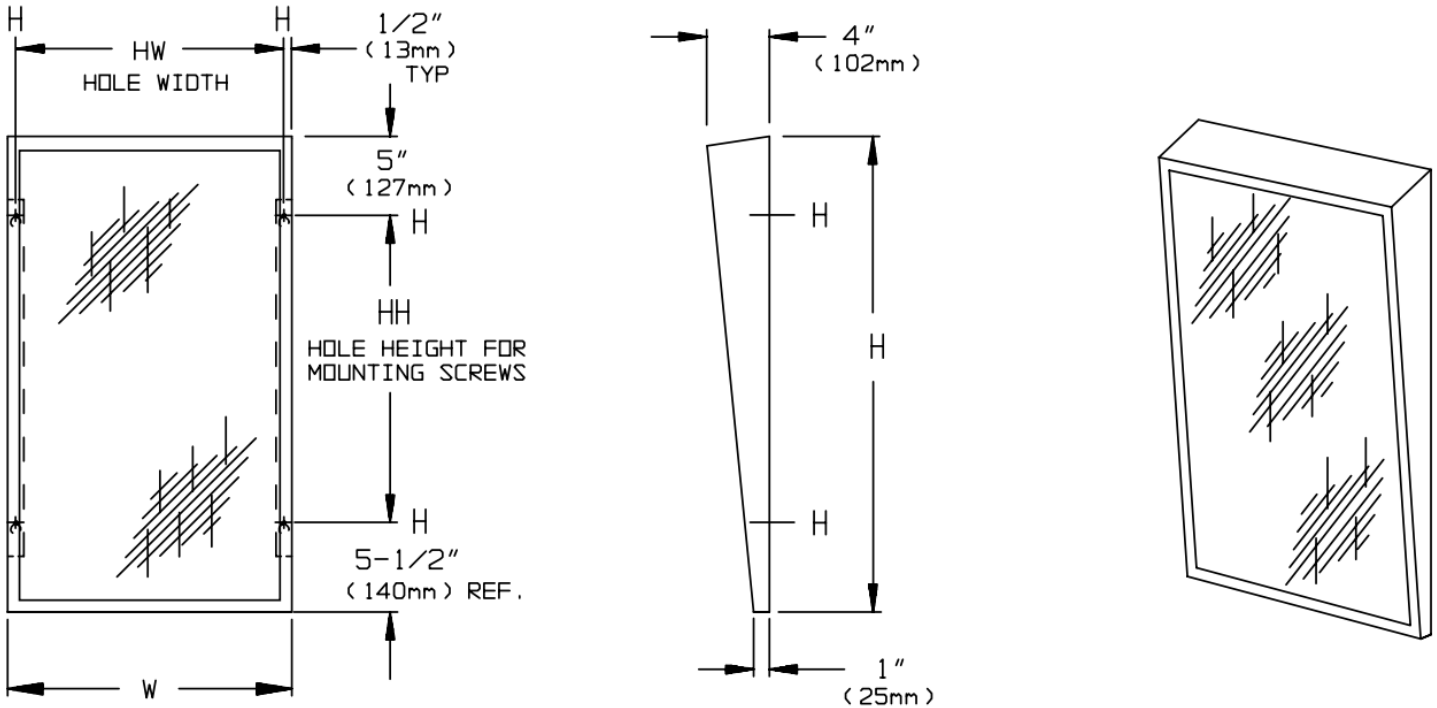

SPECIFICATION

Fixed Angle Tilted Mirror shall be fabricated of alloy 18-8 stainless steel, type 304, 20 gauge. Face shall be one piece construction free of miters or spot welded seams. All exposed surfaces shall have No 4 satin finish and be protected during shipment by plastic PVC film easily removable after installation. Concealed tamper resistant locking devices shall be provided. Mirror shall be _____ (INSERT GLAZING OPTION) and shall be warranted for 15 years against silver spoilage. Mirrors shall be supplied as standard with glazing option ' A '. For a complete description and other choices of glazing options, see the Mirror Glazing OPTIONS Chart.

Fixed Angle Tilted Mirror shall be Model No 0535-_____ (insert glazing option) - _____ (insert size code) manufactured by American Specialties, Inc., Yonkers, NY 10701-4913.

INSTALLATION

Unit is surface mounted on wall or partition using four (4) No 10 self tapping screws (by others). Mounting holes through back are "keyhole" slots for hanging unit on pre-installed screws. Unit requires $5/8"$ (16mm) clearance at top to engage screws in keyhole slots. For compliance with 2010 ADA Accessibility Standards, bottom of reflecting surface should be installed $40"$ (1016mm) max. above finished floor.

AVAILABLE MODELS

MODEL No	DIMENSIONS			
	W	H	HW	HH
0535-____-1630	16" (406mm)	30"(762mm)	15"(381mm)	19-1/2"(495mm)
0535-____-1824	18" (457mm)	24"(610mm)	17" (432mm)	13-1/2"(343mm)
0535-____-1830	18" (457mm)	30"(762mm)	17" (432mm)	19-1/2"(495mm)
0535-____-1836	18" (457mm)	36"(914mm)	17" (432mm)	25-1/2"(648mm)
0535-____-2430	24" (610mm)	30"(762mm)	23" (584mm)	19-1/2"(495mm)
0535-____-2436	24" (610mm)	36"(914mm)	23" (584mm)	25-1/2"(648mm)



AMERICAN SPECIALTIES, INC.
 441 Saw Mill River Road, Yonkers, NY 10701
 (914) 476.9000 • (914) 476.0688
 www.americanspecialties.com

MODEL №:	GLAZINGS
ISSUED:	1-87
REVISED:	22 MAY 2014

MIRROR GLAZING OPTIONS

GLAZING SUFFIX	DESCRIPTION
A	Plate Glass - 1/4" (6.4mm) thick № 1 quality polished, silver coated and hermetically sealed with a uniform coating of electrolytic copper plating. Mirrors meet Federal Spec. № DD-M-411C, ASTM C-1503 and ASTM-C-1036-91. Image quality: Excellent
B (1,2,3)	Tempered Glass - 1/4" (6.4mm) thick polished tempered glass with two coats of silver applied. Electroplating with a heavy uniform coating of copper hermetically seals the silver. Back of mirror is finished and protected with a thick coat of heavy waterproof paint. Glazing meets Federal Specification № DD-G1403B, Amendment 1, ASTM C-1503 and ASTM-C-1048-92. Image quality: Good
C (1,2,3)	Metal Mirrors - Shall be Type 304 alloy 18-8 stainless steel, 20 gauge polished to a № 8 mirror finish. Image quality: Good
D (1)	Lexan Dura-Mirror - 1/4" (6.4mm) thick polycarbonate sheet, highly impact resistant. Mirror face is provided with a thick removable masking to prevent scratching during installation. Image quality: Very Good
E (1)	Plexiglas® - Shall be 1/4" (6.4mm) thick acrylic plastic, lightweight and highly shock resistant. Image quality: Very Good
L (1)	Mirror is fabricated with an interlayer of 1/32" (.8mm) thick vinyl bonded between two 1/8" (3mm) thick sheets of № 1 quality polished plate glass with back silver coated and hermetically sealed with a uniform coating of electrolytic copper plating. Back of mirror is finished and protected with a thick coat of heavy-duty waterproof paint. Laminated glass meets the performance criteria of Federal Spec. № DD-M-451 and ANSI Z87.1 specifications and complies with CPSC standards 16 CR 1201 (1) 11. Image quality: Excellent

NOTES

1. Glazing types indicated are particularly suited to applications where frequent breakage and/or security problems exist. These surfaces are best specified for use in prisons, schools, police stations, hospital wards, etc., where shards of broken glass might possibly be used as weapons.
2. The reflective quality of these mirror types is not as true as plate glass.
3. ASI will not accept returns of these mirror types based upon claims of distortion in reflective properties.

Standard Lockers the industry benchmark

Single, Double, Triple & Four Tier, Box, Two Person, Duplex and Double Door



Lock Combination Listings and Master Keys: Use only when combination locks are specified. Delivered directly to the owner's representative.

1.3 QUALITY ASSURANCE:

1.3.1 UNIFORMITY: Provide each type of metal locker as produced by a single manufacturer, including necessary accessories, fittings and fasteners.

1.3.2 JOB CONDITIONS: Do not deliver metal lockers until building is enclosed and ready for locker installation. Protect from damage during delivery, handling, storage and installation.

PART 2- PRODUCTS

2.1 MANUFACTURER:

Republic Storage Systems, LLC. Products by other manufacturers may be approved provided they meet the detailed specifications written below. Approval procedure shall be as specified in the General Conditions of these locker specifications.

2.2 LOCKERS:

Configuration:

- Single Tier Double Tier Triple Tier
 Four Tier Two Person Duplex
 Double Door Box

Size:

Color:

No. of Locker Frames:

No. of Locker Openings:

PART 1- GENERAL

1.1 RELATED DOCUMENTS:

We suggest use of your standard office reference to drawing, general and special conditions, etc.

1.2 SCOPE:

Furnish and install new steel lockers, accessories and finish metal trim as shown or indicated on approved drawings. Concrete or masonry bases, wood furring, blocking or trim as may be required by drawings are included in other sections of this specification.

1.2.1 SUBMITTALS:

Shop Drawings: Submit drawings showing locker types, sizes and quantities, including all necessary details relating to anchoring, trim installation and relationship to adjacent surfaces.

Numbering: The locker numbering sequence shall be provided by the approving authority and noted on the approved drawings returned to the locker contractor.

Color Charts: Provide color charts showing manufacturer's available colors. If required by normal office procedures or in the event of non-standard color selection, request samples of paint on metal.

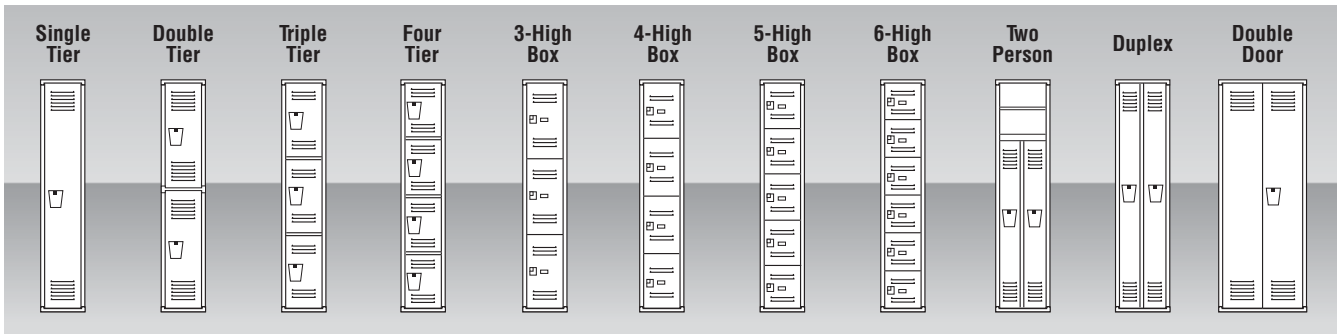

Standard Lockers the industry benchmark

Single, Double, Triple & Four Tier, Box, Two Person, Duplex and Double Door

2.3 FABRICATION - GENERAL:

2.3.1 MATERIAL: All major steel parts shall be made of mild cold rolled steel, free from imperfections and capable of taking a high grade baked enamel or powder coat finish.

-ALTERNATE: Specified locker components shall be manufactured from Galvannealed steel and finished by manufacturer's standard process.

2.3.2 FINISH: Surfaces of the steel shall be thoroughly cleaned, phosphatized and prepared for baked enamel or powder coat finish in accordance with paint manufacturer's instructions.

2.3.3 CONSTRUCTION: Lockers shall be built on the unit principle - each locker shall have an individual door and frame, an individual top, bottom, back and shelves with common intermediate uprights separating units.

2.3.4 DOOR FRAMES: Door frames shall be 16 gauge formed into 1" wide face channel shapes with a continuous vertical door strike, integral with the frame on both sides of the door opening. Double, triple or four tier locker cross frame members shall be 16 gauge channel shaped securely welded to vertical framing members to ensure a square and rigid assembly. Intermediate cross frame members are not required on box lockers.

2.3.5 DOORS: Shall be 16 gauge or 18 gauge steel for short or narrow doors as required by manufacturer's design, formed with a full channel shape on the lock side to fully conceal the lock bar, channel formation on the hinge side and right angle formation across the top and bottom. Single tier doors 60" and 72" in height and 18" and wider shall have a diagonal reinforcing angle welded to inner surface. Doors for Standard Box Lockers 3, 4, 5 and 6 openings high are 16 or 18 gauge steel and shall be formed with right angle flanges on all four sides. Locker doors shall be ventilated by louvers on the face of each door, top and bottom.

2.3.6 PRE-LOCKING DEVICE: All "tiered" lockers shall be equipped with a positive automatic pre-locking device, whereby the locker may be locked while door is open and then closed without unlocking and without damaging locking mechanism.

2.3.7 LATCHING: Latching shall be a one-piece, pre-lubricated spring steel latch, completely contained within the lock bar under tension to provide rattle-free operation. The lock bar shall be of pre-coated, double-channel steel construction. The lock bar shall be securely contained in the door channel by self-lubricating polyethylene guides that isolate the lock bar from metal-to-metal contact with the door. There shall be three latching points for

lockers over 42" in height and two latching points for all tiered lockers 42" and under in height. The lock bar travel is limited by contacting resilient high-quality elastomeric cushioning devices concealed inside the lock bar. Frame hooks to accept latching shall be of heavy gauge steel, set close in and welded to the door frame. Continuous vertical door strike shall protect frame hooks from door slam shall protect frame hooks from door slam damage. A soft rubber silencer shall be securely installed on each frame hook to absorb the impact caused by closing of the door. Box locker doors shall be equipped with a padlock hasp and a stainless steel strike plate with an integral handle pull. Box locker doors may also be equipped with built-in locks.

2.3.8 HANDLES: A non-protruding 14 gauge lifting trigger and slide plate shall transfer the lifting force for actuating the lock bar when opening the door. The exposed portion of the lifting trigger shall be encased in a molded ABS thermoplastic cover that provides isolation from metal-to-metal contact and be contained in a formed 20 gauge stainless steel recessed pocket. This stainless steel pocket shall contain a recessed area for the various lock types available and a mounting area for the number plate.

2.3.9 HINGES: Hinges shall be 2" high, 5-knuckle, full loop, tight pin style, securely welded to frame and double riveted to the inside of the door flange. Locker doors 42" high and less shall have two hinges. Doors over 42" high shall have three hinges.

2.3.10 BODY: The body of the locker consists of 24 gauge upright sheets, backs, tops, bottoms and shelves. Tops, bottoms and shelves are flanged on all four sides; backs are flanged on two sides. Uprights shall be offset at the front and flanged at the rear to provide a double lapped rear corner. All bolts and nuts shall be zinc plated.

2.3.11 INTERIOR EQUIPMENT: Single tier lockers over 42" high shall have one hat/book shelf. Other tiered lockers do not require shelves. All single, double and triple tier lockers shall have one double prong rear hook (single prong in 9" width) and two single prong side hooks in each compartment. All hooks shall be made of steel, formed with ball points, zinc-plated and attached with two bolts or rivets. Locker openings under 20" high are not equipped with hooks.

2.3.12 NUMBER PLATES: Each locker shall have a polished aluminum number plate with black numerals not less than 1/2" high. Plates shall be attached with rivets to the lower surface within the recessed handle pocket.

2.3.13 COLOR: Doors and exposed body parts shall be finished in colors selected from Republic's collection of twenty-five baked enamel colors. Non-exposed body parts shall be finished in #83 Decorator Tan (baked enamel).

-ALTERNATE: Doors and exposed body parts shall be finished in colors selected from Republic's collection of nine powder coat colors. Non-exposed body parts shall be finished in #83 Decorator Tan (baked enamel).

-ALTERNATE: Entire locker shall be finished in colors selected from Republic's collection of nine powder coat colors.

-OPTION: Specifier may modify above paragraph if non-standard custom colors are selected.

2.3.14 ASSEMBLY: Assembly of all locker components shall be accomplished by the use of zinc plated, low round head, slotless, fin neck machine screws with hex nuts, producing a strong mechanical connection.

-OPTION: Keps nuts and bolts or rivets and washers may be used for assembly.

PART 3 - EXECUTION

3.1 INSTALLATION:

Lockers must be installed in accordance with manufacturer's approved drawings and assembly instructions. Installation shall be level and plumb with flush surfaces and rigid attachment to anchoring surfaces. Space fasteners at 36" O.C. or less, as recommended by manufacturer. Use fasteners appropriate to load and anchoring substratum. Use reinforcing plates wherever fasteners could distort metal. Various trim accessories where shown, such as sloping tops, fillers, bases, recessed trim, etc., shall be installed using concealed fasteners. Flush, hairline joints are provided at all abutting trim parts and at adjoining surfaces.

3.2 ADJUSTMENT:

Upon completion of installation, inspect lockers and adjust as necessary for proper door and locking mechanism operation.

3.3 QUALITY ASSURANCE:

Republic reserves the right to modify the design and/or change specifications or colors/finish consistent with our policy of product excellence.

NOTE: For user safety, all Republic lockers must be secured to the wall and/or floor prior to use.

ELKAY®

SPECIFICATIONS

EZH2O® Bottle Filling Station with Single EZ Cooler Models EZS8WS & EZSDWS

RATED FOR INDOOR USE ONLY

PRODUCT SPECIFICATION

Unit shall include electric water cooler with bottle filling station. EZS8WS shall deliver 8 GPH of 50°F drinking water at 90°F ambient and 80°F inlet water. EZSDWS shall deliver non-chilled drinking water. Units shall have pushbar activation. Bottle filling unit shall include an electronic sensor for touchless activation with auto 20-second shut-off timer. Shall include Green Ticker™ displaying count of plastic bottles saved from waste. Bottle filler shall provide 1.1-1.5 gpm flow rate with laminar flow to minimize splashing. Shall include integrated silver ion anti-microbial protection in key areas. Unit shall meet ADA guidelines. Unit shall be lead-free design which is certified to NSF/ANSI 61 and 372 and meets Federal and State low-lead requirements. Unit shall be certified to UL399 and CAN/CSA 22.2 No. 120.

STANDARD FEATURES

- Sanitary, touchless activation with auto 20-second shut-off (Bottle Filler)
- Easy-touch front and side pushbar controls (Cooler)
- Integrated Silver Ion Anti-microbial Protection in key areas
- Quick Fill Rate: 1.1 gpm (EZS8WS); 1.5 gpm (EZSDWS)
- Laminar Flow provides minimal splash
- Real Drain System eliminates standing water
- Visual User Interface display includes:
 - Innovative Green Ticker™ counts bottles saved from waste
- Available with Flexi-Guard® StreamSaver™ or Vandal-Resistant® bubbler (includes "VR" code in model no.)
- Cooler panel finishes: Light Gray Granite Vinyl Clad Steel or Stainless Steel

COOLING SYSTEM (Models EZS8WS & EZS8WSVR only)

- Compressor: hermetically-sealed, reciprocating type, single phase. Sealed-in lifetime lubrication.
- Condenser: Fan cooled, copper tube with aluminum fins. Fan motor is permanently lubricated.
- Cooling Unit: Combination tube-tank type. Self-cleansing. Continuous copper tubing with stainless steel tank. Fully insulated with EPS foam which meets UL requirements for self-extinguishing material.
- Refrigerant Control: Refrigerant R134a is controlled by accurately calibrated capillary tube.
- Temperature Control: Easily accessible enclosed adjustable thermostat is factory preset. Requires no adjustment other than for altitude requirements.

CAPACITIES CHART

Model	Voltage / Hertz	Chilling** Capacity	F.L. Amps	Rated Watts	Approx. Ship Wt.
EZS8WS(VR)*K	115V / 60Hz	8 GPH	5.0	370	88
EZS8WS(VR)*2K	220V / 50Hz	6.7 GPH	2.5	370	
EZS8WS(VR)*3K	220V / 60Hz	8 GPH	2.5	370	
EZSDWS(VR)*K	115V / 60Hz	-	1.0	15	58
EZSDWS(VR)*2K	220V / 50Hz	-	0.5	15	
EZSDWS(VR)*3K	220V / 60Hz	-	0.5	15	

*Color code of (L) Light Gray Granite or (S) Stainless Steel cooler panels.

**Based on 80°F inlet water & 90°F ambient air temp for 50°F chilled drinking water.

In keeping with our policy of continuing product improvement, Elkay reserves the right to change specification without notice. Please visit elkaypro.com for the most current version.

2222 Camden Court
OakBrook, IL 60523
630-572-3192
elkaypro.com

RATED FOR INDOOR USE ONLY



Models EZS8WS
or EZSDWS



Models
EZS8WSVRLK
or
EZSDWSVRLK

CONSTRUCTION

- Stainless Steel basin with integral drain
- Galvanized structural steel cooler chassis provides structural integrity
- Stainless steel bottle filler wrapper with ABS plastic Alcove
- Cooler cabinet available as Light Gray Granite Vinyl Clad Steel or Stainless Steel (additional cost) construction
- Flexi-Guard® StreamSaver™ Safety Bubbler (option) utilizes an infused anti-microbial pliable polyester elastomer to prevent accidental mouth injuries. Flexes on impact. Lower-flow water efficient water stream.
- Vandal-resistant bubbler (option) is one-piece heavy-duty chrome-plated

Warranty: 5 year limited warranty on the unit's refrigeration system. Electrical components and water system are warranted for 12 months from date of installation or 18 months from factory shipment, whichever date falls first.

CERTIFICATIONS / STANDARDS

- ADA Compliant
- UL399 and CAN/CSA 22.2 No. 120 Certified (Only 115V models are certified)
- ANSI/NSF 61 and 372 Certified
- GreenSpec® Listed



This specification describes an Elkay product with design, quality and functional benefits to the user. When making a comparison of other producer's offerings, be certain these features are not overlooked.

EZH20[®] Bottle Filling Station with Single EZ Cooler Models EZS8WS & EZSDWS

ELKAY[®] ROUGH-IN

RATED FOR INDOOR USE ONLY

IMPORTANT! INSTALLER PLEASE NOTE:

These units are designed and built to provide water to the user which has not been altered by materials in the cooler waterway. The grounding of electrical equipment such as telephone, computers, etc. to water lines is a common procedure. This grounding may be in the building but may also occur away from the building. This grounding can cause electrical feedback into a water cooler creating an electrolysis which results in a metallic taste or an increase in the metal content of the water. This condition is avoidable by installing the cooler using the proper materials as shown.

Model shown with Flexi-Guard StreamSaver Bubbler.

NOTICE

This water cooler must be connected to the water supply using a dielectric coupling. The cooler is furnished with a non-metallic strainer which meets this requirement. The drain trap which is provided by the installer should also be plastic to completely isolate the cooler from the building plumbing system.

Bottle Filler unit will mount on bracket attached to wall by 6 holes (as shown). Water and electrical will connect through pre-punched hole in basin.

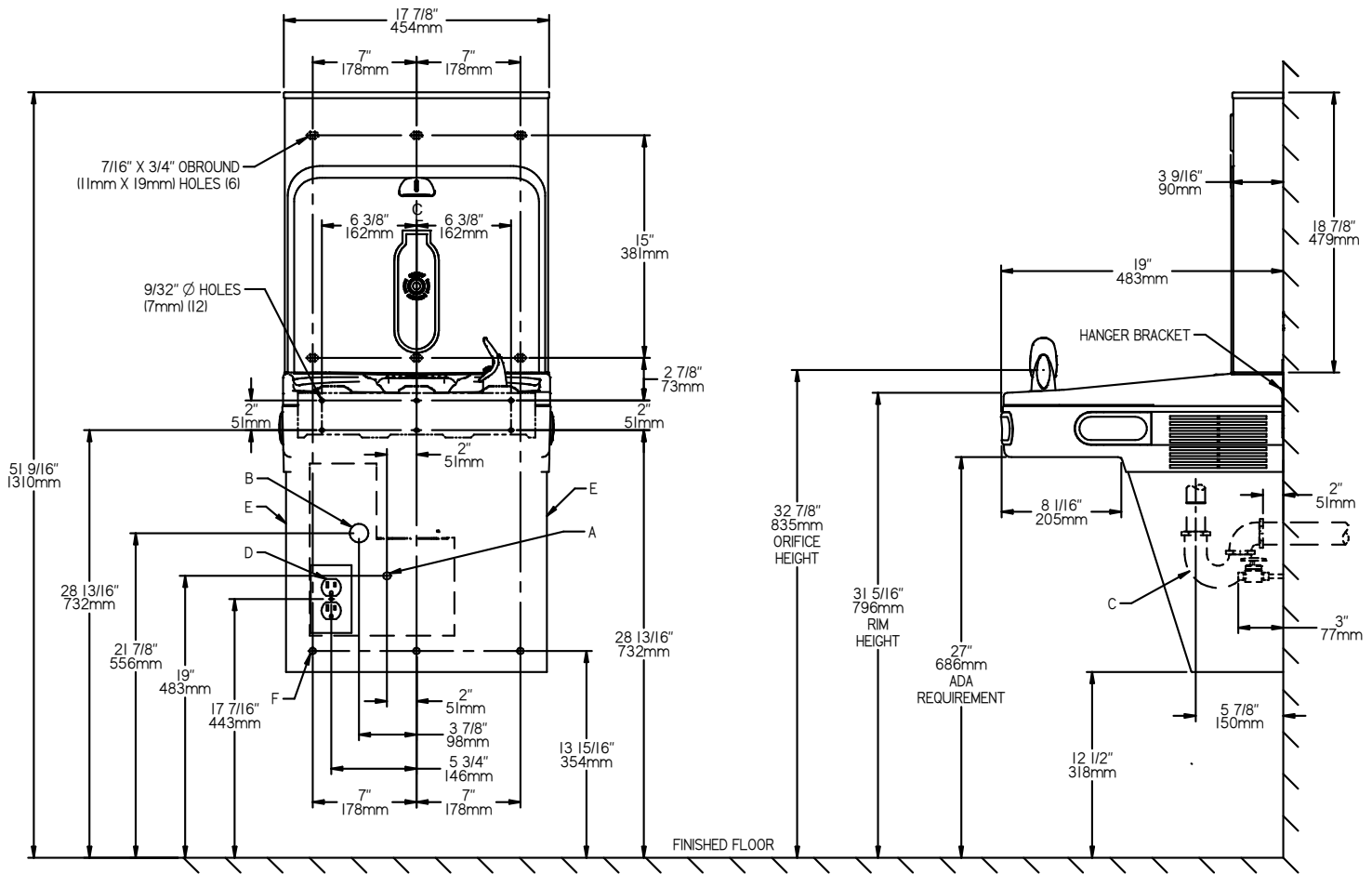

REDUCE HEIGHT BY 3 INCHES FOR INSTALLATION OF CHILDRENS ADA COOLER

LEGEND:

- A = Recommended Water Supply location. Shut-off Valve (not furnished) to accept 3/8" O.D. unplated copper tube. Up to 3" (76mm) maximum out from wall.
- B = Recommended Waste Outlet location. To accommodate 1-1/4" nominal drain. Drain stub 2" (51mm) out from wall.
- C = 1-1/4" Trap (not furnished).
- D = Electrical Supply (3) Wire Recessed Box Duplex Outlet.
- E = Insure proper ventilation by maintaining 6" (152mm) minimum clearance from cabinet louvers to wall.
- F = 7/16" (11mm) Bolt Holes for fastening to wall.

**New Installations Must Use Ground Fault Circuit Interrupter (GFCI).

Job Name:	_____
Model:	_____ Qty. _____
Contact:	_____
Approval Signature:	_____
Notes:	_____



Architect/Engineering Specifications:

4" centerset deck mount mixing faucet with polished chrome plated brass body and integral spout, 2.2 GPM aerator, metering cartridges, push button caps and 1/2" NPSM male inlets. Certified to ASME A112.18.1/CSA B125.1, NSF 61-Section 9 and NSF 372. Meets ADA ANSI/ICC A117.1 requirements.

Job Name _____
 Model Specified _____ Quantity _____
 Variations Specified _____
 Date _____

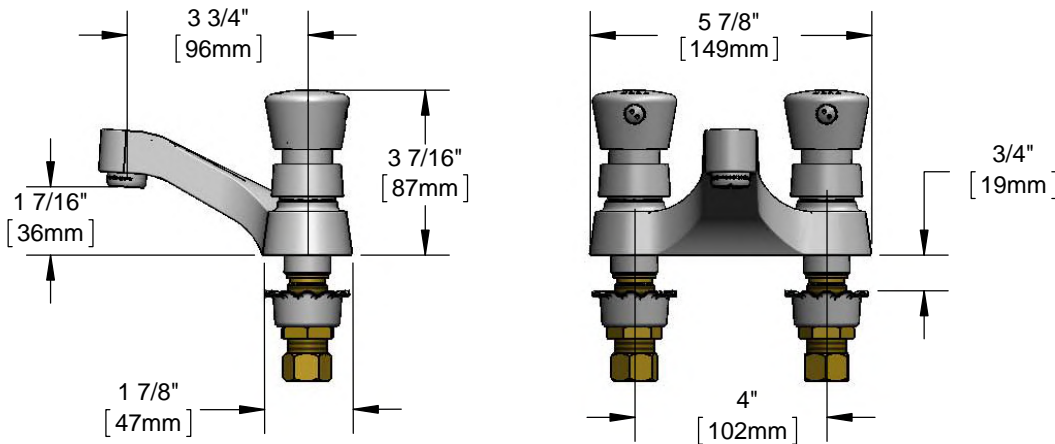

Features & Benefits:

- 4" centerset deck mount mixing faucet w/ polished chrome plated brass body and integral spout
- 2.2 GPM aerator, Series 3 (B-0199-03)
- Metering cartridges
- Adjustable metering cycle, 10 to 30 seconds
- Push button (hot & cold) caps w/ vandal resistant screws
- 1/2" NPSM male inlets
- Material: Polished chrome plated brass body & spout and chrome plated metal caps

Product Compliance:

- ASME A112.18.1 / CSA B125.1
- NSF 61 - Section 9
- NSF 372 (Low Lead Content)
- ANSI A117.1 (ADA)



Warranty: One Year (Limited)

Performance Data:

- Pressure: 20 - 125 psi
- Temperature: 40 °F - 140 °F
- Flow Rate: 2.2 GPM @ 60 psi
- Water Consumption: @ 10 sec = .37 gal
@ 15 sec = .55 gal



Optional Outlets (Series 3 / VR Series 8)

GPM	Aerated	Non-Aerated (Laminar)	VR Aerated	VR Non-Aerated (VR Laminar)	Optional Cartridges
0.35	N/A	<input type="checkbox"/> B-0199-03-N035	N/A	<input type="checkbox"/> B-0199-08-N035	<input type="checkbox"/> Push Button Metering (Standard)
0.5	N/A	<input type="checkbox"/> B-0199-03-N05	N/A	<input type="checkbox"/> B-0199-08-N05	<input type="checkbox"/> Pivot Action Metering
1.0	N/A	N/A	N/A	<input type="checkbox"/> B-0199-08-LF-10	<input type="checkbox"/> Wrist Action Metering
1.5	<input type="checkbox"/> B-0199-03-WS	N/A	<input type="checkbox"/> B-0199-08-WS	N/A	
2.2	Standard	<input type="checkbox"/> B-0199-26	<input type="checkbox"/> B-0199-08	<input type="checkbox"/> B-0199-28	

