



Agenda Item: III A: Information/Discussion Item

Date: September 8, 2021

To: Magnolia Educational & Research Foundation dba Magnolia Public Schools (“MPS”) Facilities Committee (the “Committee”)

From: Alfredo Rubalcava, Chief Executive Officer and Superintendent

Staff Lead: Patrick Ontiveros, General Counsel & Director of Facilities  
Mustafa Sahin, Project Manager

RE: Update on Shade Structure Project for Magnolia Science Academy—1 (“MSA-1”) High School Building

---

## I. Proposed Motion/Recommendation(s)

N/A

## II. Background

The new MSA-1 high school building located at 18220 Sherman Way, immediately adjacent to the existing MSA-1 middle school building at 18238 Sherman Way, was completed and occupied at the end of 2019. The principal entrance to the high school building is from the alley that is parallel to Sherman Way to the south. There is also a lunch area right outside the multipurpose room on the south side of the building that is fenced in but not shaded. See Exhibit A for the site layout and the location of the courtyard.

For the 2021-22 school year and beyond, MSA-1 leadership desired to have more usable outdoor space at MSA-1. Accordingly, Staff approached multiple vendors and issued an RFP for the installation of shade at the high school building courtyard. Staff selected a vendor and sought Board approval. The Board approved the vendor and the proposal to construct a shade structure on June 24, 2021. At that time, the final design was still being finalized and Staff was not aware of how extensive the recommendations from the structural engineer would be. Staff believed there was a fair chance that the shade sails would be able to be attached to the building. However, ultimately, the structural engineer recommended erecting the shade structure as a standalone structure (that is, shade sails suspended from columns not attached to the building). That work entailed digging 8 holes, 9 feet deep each, to place the columns from which the shade sails would be suspended and backfill the holes with cement to be strong enough to hold the shade

structure. The design work and construction was further complicated by its proximity to the building foundations.

The project was a success and has allowed MSA-1 and MSA-5 to better and more effectively use the MSA-1 high school courtyard. See attached [Exhibit B-1](#) for before pictures of the courtyard and [Exhibit B-2](#) for pictures of the completed project.

### **III. Procurement**

We received 2 quotes, one of them was \$32,500.00 by Universal Awning, the other one was \$25,200.00 by AG Construction. They were also available to start the job in the following week. See [Exhibit C](#) for those 2 quotes. AG presented an economical solution that aligned with the requirements. That's why staff chose AG for this project. See [Exhibit D](#) for the explanation by the structural engineer and the design of the foundation system for the shade structure.

### **IV. Budget & Conclusion**

A majority of the project expenses were paid for with a grant of \$64,841.63, through Schools in Action, which operates MSA-1's meal program. Staff requested and the Board approved a limit of \$75,000 to account for any unforeseen conditions that may increase the price of \$68,750. The cushion of \$6,250 was insufficient for the final structural engineer recommendations. Costs exceeding the original approved \$75,000 budget were approved by Alfredo Rubalcava using his then extraordinary executive powers. With the impending start of school, Staff including the principal and administration of MSA-1, believed that the completion of this project before the start of school was critical to a successful opening. Excess costs were paid for using operation funds and there was no material negative impact to MSA-1's budget.

The total final costs were as follows: \$68,750 for the fabrication and installation of the shade sails, \$25,200 for the concrete work and \$4,800 for the structural engineers final design for a total of \$98,750 or \$23,750 over the original approved budget.

# Exhibit A

## Site Layout and Location of Proposed Shading

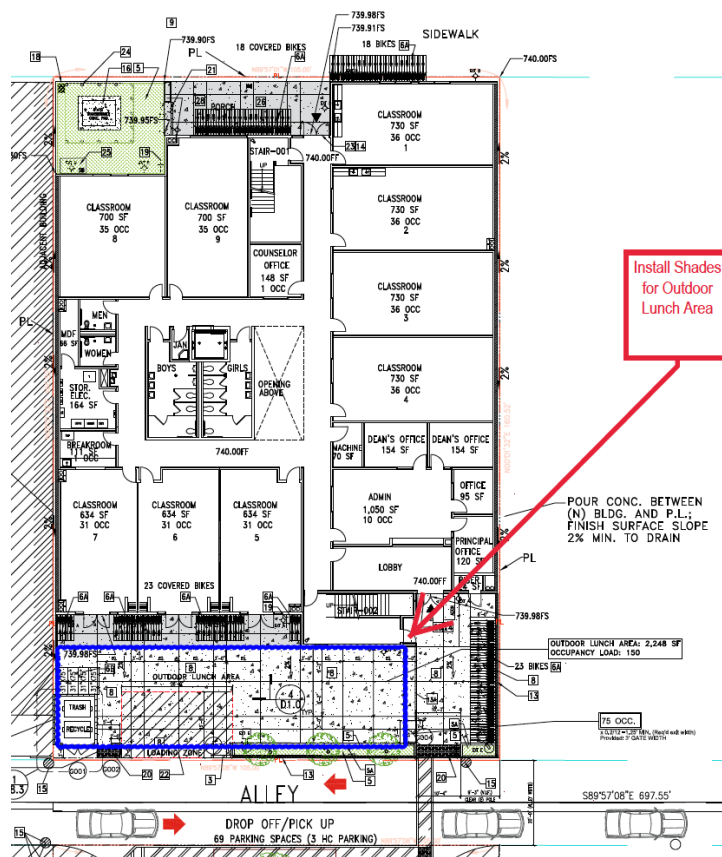



Exhibit B-1

Pictures of High School Courtyard Before Shade Installation





## Exhibit B-2

### Pictures of Installed Shade Structure



**AG CONSTRUCTION**

18960 Ventura Blvd. #211

Tarzana, CA 91356

Tel. No. (818)963-1683

Fax No. (818)344-1850

License No. 706172

Email: agconstruction18@gmail.com

**AG CONSTRUCTION****PROPOSAL**

<b>This proposal is submitted to:</b>	<b>Project Address:</b>	2021-27
Mr Partic Anton Esq and Mustafa Sahin 250 East 1st Street suite 1500 LA, Ca 90012	MSA 18238 Sherman Way Reseda Ca 91335	

DESCRIPTION	AMOUNT
07/19/21 1) Digging 9 cassion 9 ft deep and 3 Tie beams Per plan attached  2) Placing rebar in all 9 cassion and tie beams Per plan attached  3) Meeting engineer for observation before inspection  4) Pour concrete 3000 PSI with deputy in all caisson and tie beams Finish cement to surface to match existing finish 5) Clean and haul all debrits  * All work to comply with plan attached to this proposal * Price include Deputy Inspection cost for Concrete pour * All post culums place in caisson by awning company * All permit processing, and fees by other * Price exclude all Engineering observation cost * Price base on one pour * All landscaping repair by other  <div style="text-align: right;">   <b>CEO &amp; Superintendent</b> </div>	<b>Date: 08/13/2021</b>
<b>Total Amount</b>	<b>\$ 25,200.00</b>

All the above work to be completed in a substantial and workmanlike manner according to standard practice.

Please make checks payables to : AG Construction



Exhibit C

Cement Work Proposals

# ESTIMATE



**Magnolia Science Academy**  
18220 Sherman Way  
Reseda, CA 91335

## Universal Awning

7053 Canby Ave.  
Reseda, CA 91335

Phone: (818) 882-0027

Email: Info@universalawning.com

Estimate # 001737  
Date 07/13/2021

Description	Quantity	Rate	Total
Concrete Work Per Engineer for (8 sails posts) Materials: 3000 PSI Concrete & Rebar Dimensions: 9'-0" x 2'-0" DIA Concrete Pile 3000 PSI with #5 vertical rebar, #4 rebar ties, #4 epoxy dowels 9'-0" x 2'-0" DIA Concrete Pile 3000 PSI with #5 vertical rebar, #4 rebar ties, #4 epoxy dowels 9'-0" x 2'-0" DIA Concrete Pile 3000 PSI with #5 vertical rebar, #4 rebar ties, #4 epoxy dowels 9'-0" x 2'-0" DIA Concrete Pile 3000 PSI with #5 vertical rebar, #4 rebar ties, #4 epoxy dowels 7'-6" x 2'-0" DIA Concrete Pile 3000 PSI with #5 vertical rebar, #4 rebar ties, #4 epoxy dowels 7'-6" x 2'-0" DIA Concrete Pile 3000 PSI with #5 vertical rebar, #4 rebar ties, #4 epoxy dowels 7'-6" x 2'-0" DIA Concrete Pile 3000 PSI with #5 vertical rebar, #4 rebar ties, #4 epoxy dowels 7'-6" x 2'-0" DIA Concrete Pile 3000 PSI with #5 vertical rebar, #4 rebar ties, #4 epoxy dowels 2'-0" wide x 0'-8" thick Tie Beam in planter on top of pile with #4 epoxy dowels 2'-0" wide x 0'-8" thick Tie Beam in planter on top of pile with #4 epoxy dowels 2'-0" wide x 0'-8" thick Tie Beam in planter on top of pile with #4 epoxy dowels Elements: #4 Rebar, #5 Rebar, 3000 PSI Concrete, Set XP epoxy.	1.0	\$32,500.00	\$32,500.00

Templates & Measurements: Included.

Shop Drawings: Included. 1 drawing, 2 revisions any additional \$110.00 per hour.

Permits: Not included.

Engineering: By others.

Finish: Trowel finish on top surface, may not match with existing finish.

Delivery & Installation: Included.

Prevailing Wages: This project was priced as a NON-prevailing wage job, if the project requires prevailing wages we will resubmit our proposal to reflect the additional cost.

Notes: Our price includes all labor, cutting existing concrete, digging, rebar work, pouring and finishing concrete. Due to the volatile material prices this quotation is valid for 7 days. Advance bill of material is required to be paid to secure material pricing.

---

<b>Subtotal</b>	\$32,500.00
<b>Total</b>	<b>\$32,500.00</b>

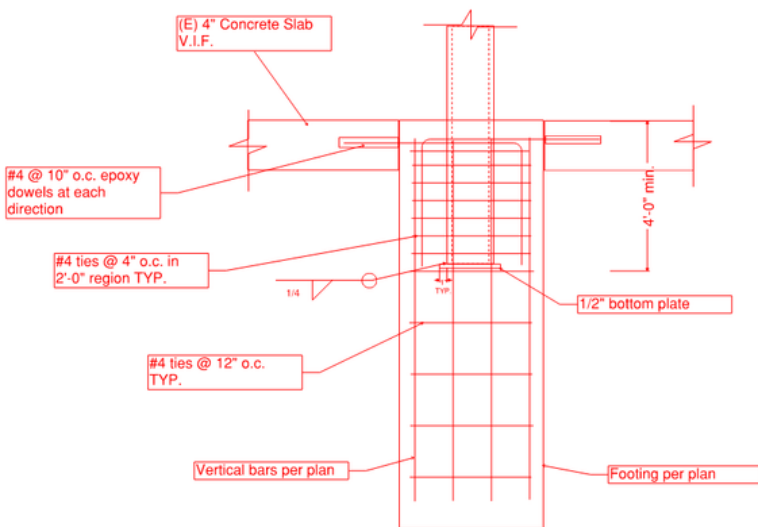
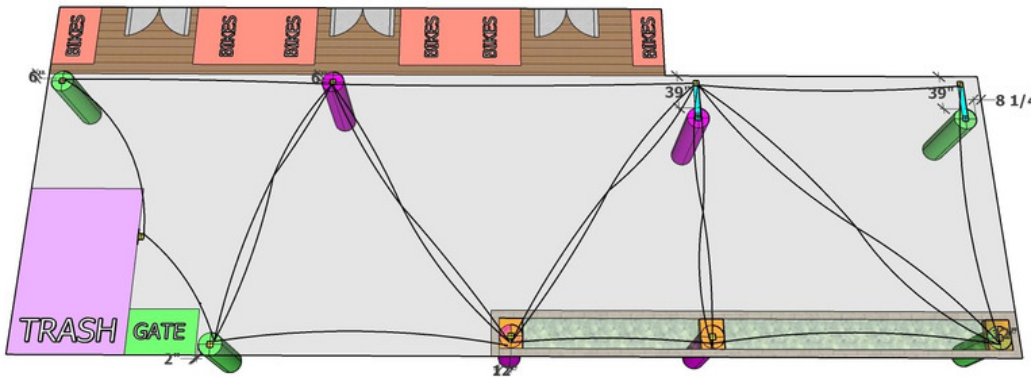

**Footing Section B-B**



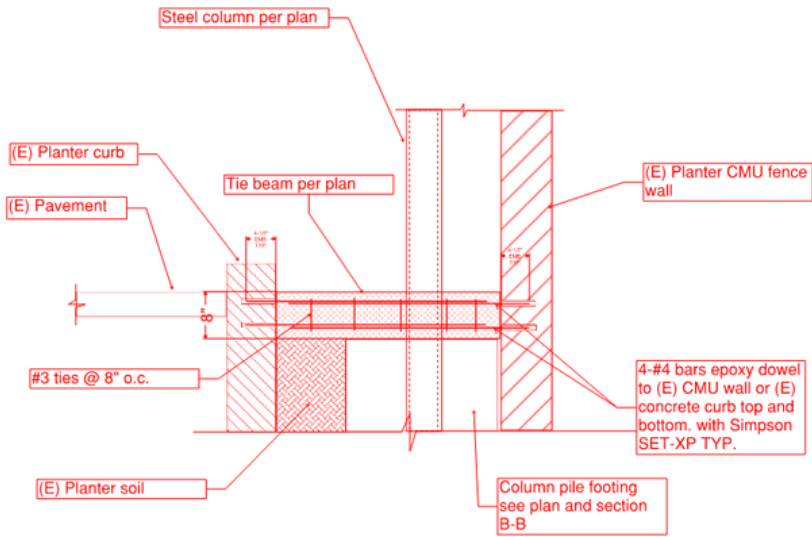

**Tie Beam Section C-C**

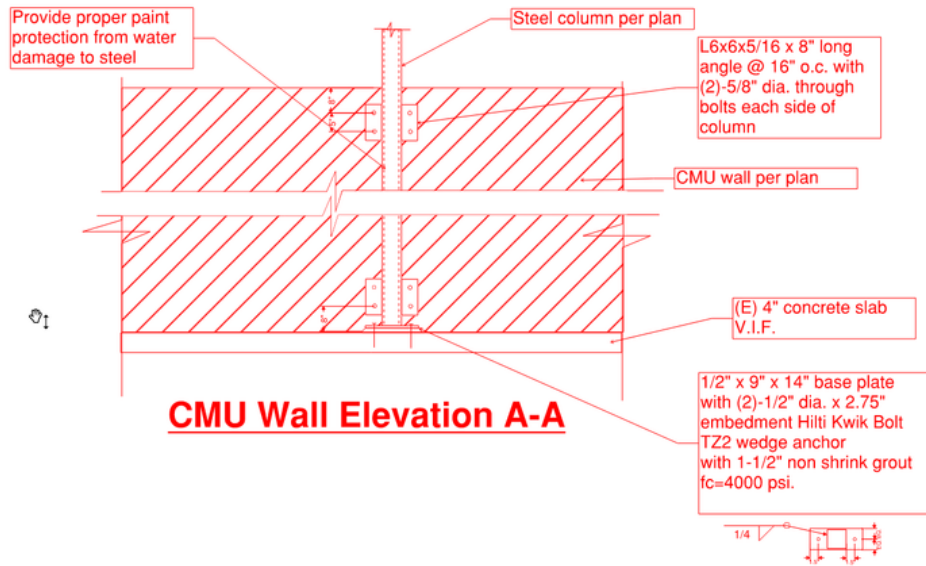

**CMU Wall Elevation A-A**

All down payments are non-refundable three business days from the signing of this contract. With respect to the above, it is agreed that three quarters of the above mentioned sum is for the cost of materials, fabrication labor, sales tax and balance is for the cost of installation labor.

In the event of default of any installment, the unpaid balance shall become due and payable forthwith at the option of the Contractor without notice.

All expenses incurred in the collection of monies due per this agreement whether by arbitration or judicial process including attorney's fees and cost shall be paid by you the purchaser.

Note: This proposal may be withdrawn by Universal Awning & Shade, Inc. at any time prior to its acceptance, and shall expire by its own terms if not accepted within 7 days. Due to the volatile steel prices this quotation is valid for 7 days. Advance bill of material is required to be paid to secure material pricing.

An initial service charge of 5% of the outstanding balance will be charged on balances not paid within five days of payment due date. service charge of 1.5% will be added each month to the balance remaining unpaid.

This quotation is not binding and does not become a contract unless signed below by UNIVERSAL AWNING & SHADE, INC. EXECUTIVE OFFICER.

---

Universal Awning - Cody Clapp

---

Magnolia Science Academy



## Exhibit D

### Structural Engineer Explanation

Good Morning Mustafa,

This is to confirm that the structural requirements for the new proposed shade canopy will include the following:

Tubular steel columns for the connections of the sail canopy  
Pier foundation that will support cantilever action in lieu of large size pad footings was designed per code requirements. Any alternate foundation such as pad footings would have had conflict with existing building structure and bio retention filtration system and would have been more costly. Depth of piers and steel column embedment will depend on field conditions and restraints.

For couple of columns existing masonry site walls was used to eliminate foundation work and to save time and money.

Thanks

Armen Baroonian, Ph.D, S.E.

Principal

B&B Associates, Inc.

Structural Engineers

867 N. Fair Oaks ave #100

Pasadena, CA 91103

Tel (626) 204-1088

Fax (626) 204-1099

armen@bnbstructural.com

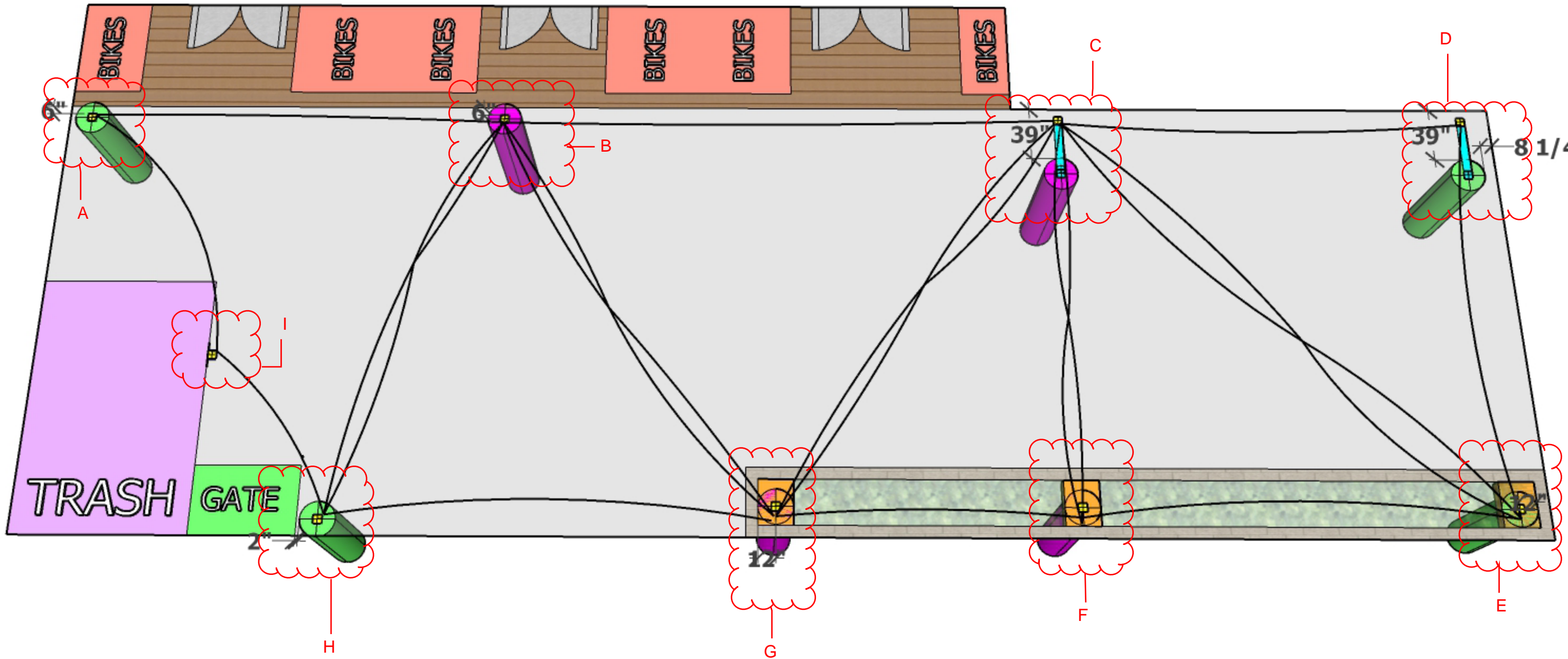

**BLK**

**6" POST IS CLEAR FROM OVERHEAD CANOPY.**

**6"**

**VIF WE ASSUME CLEAR FROM FOUNDATION**

**7'-6" x 2' DIA  
FOOTING 3000 PSI  
CONCRETE  
PER ENGINEER DETAIL  
"FOOTING SECTION B-B"**

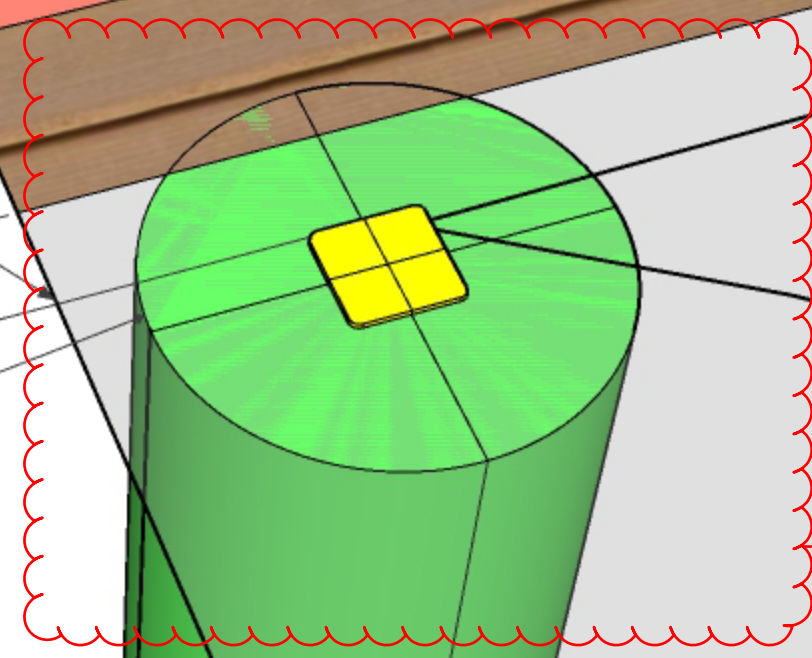

**A**



**BLK**

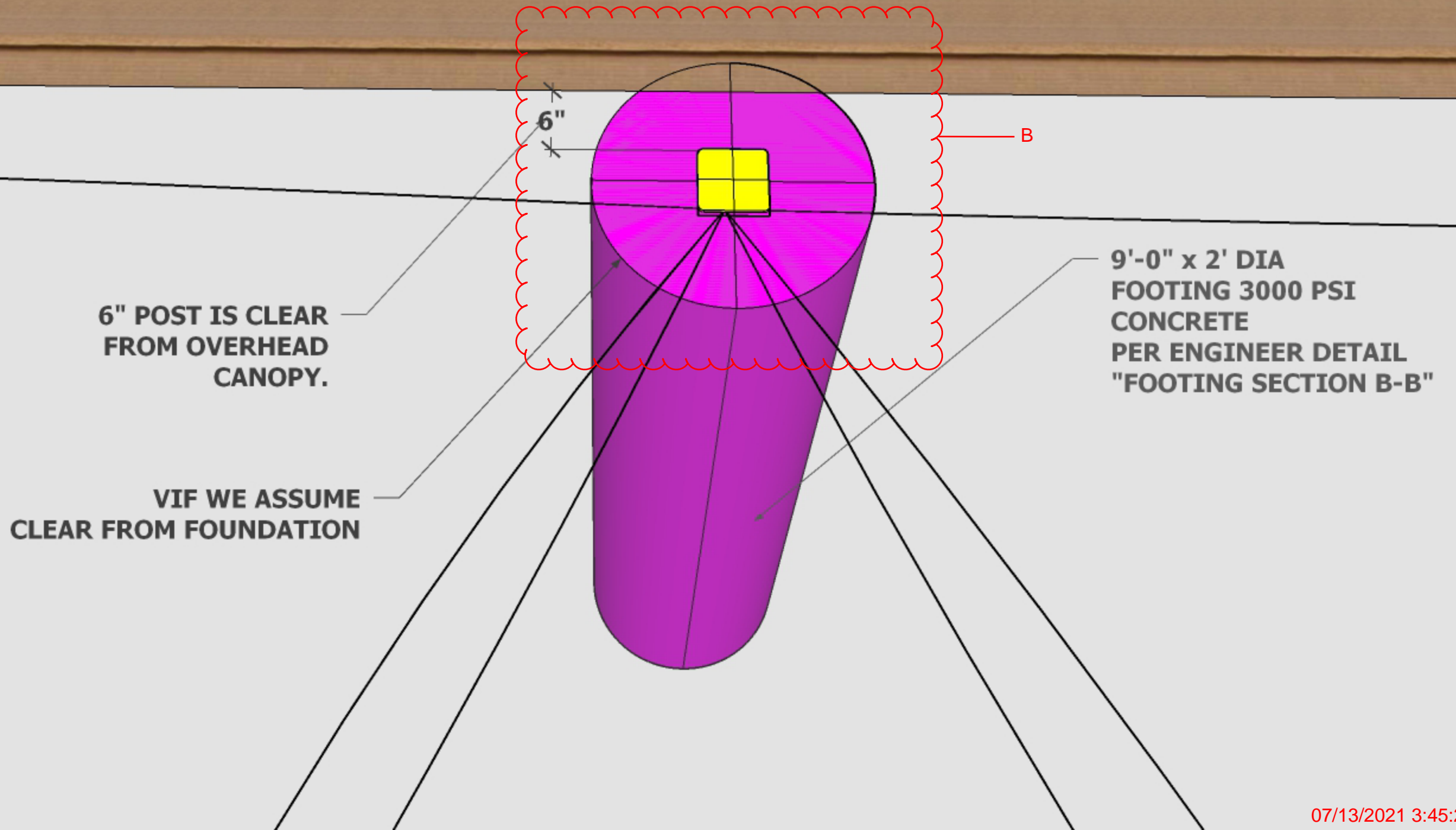



**BIKA**

**BUILDING**

**VIF THIS 39" IS ENOUGH CLEARANCE FROM THE FOUNDATION MEASURED FROM THE EDGE OF THE FOOTING.**

39"

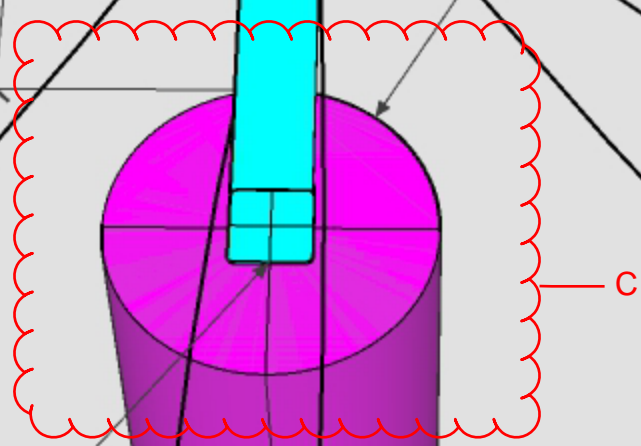

**CANTILEVER  
POST BASE**

**9'-0" x 2' DIA  
FOOTING 3000 PSI  
CONCRETE  
PER ENGINEER DETAIL  
"FOOTING SECTION B-B"**

**VIF THIS 39" IS ENOUGH CLEARANCE  
FROM THE FOUNDATION MEASURED  
FROM THE EDGE OF THE FOOTING.**

**BUILDING**

39"

8 1/4"

D

**7'-6" x 2' DIA  
FOOTING 3000 PSI  
CONCRETE  
PER ENGINEER DETAIL  
"FOOTING SECTION B-B"**

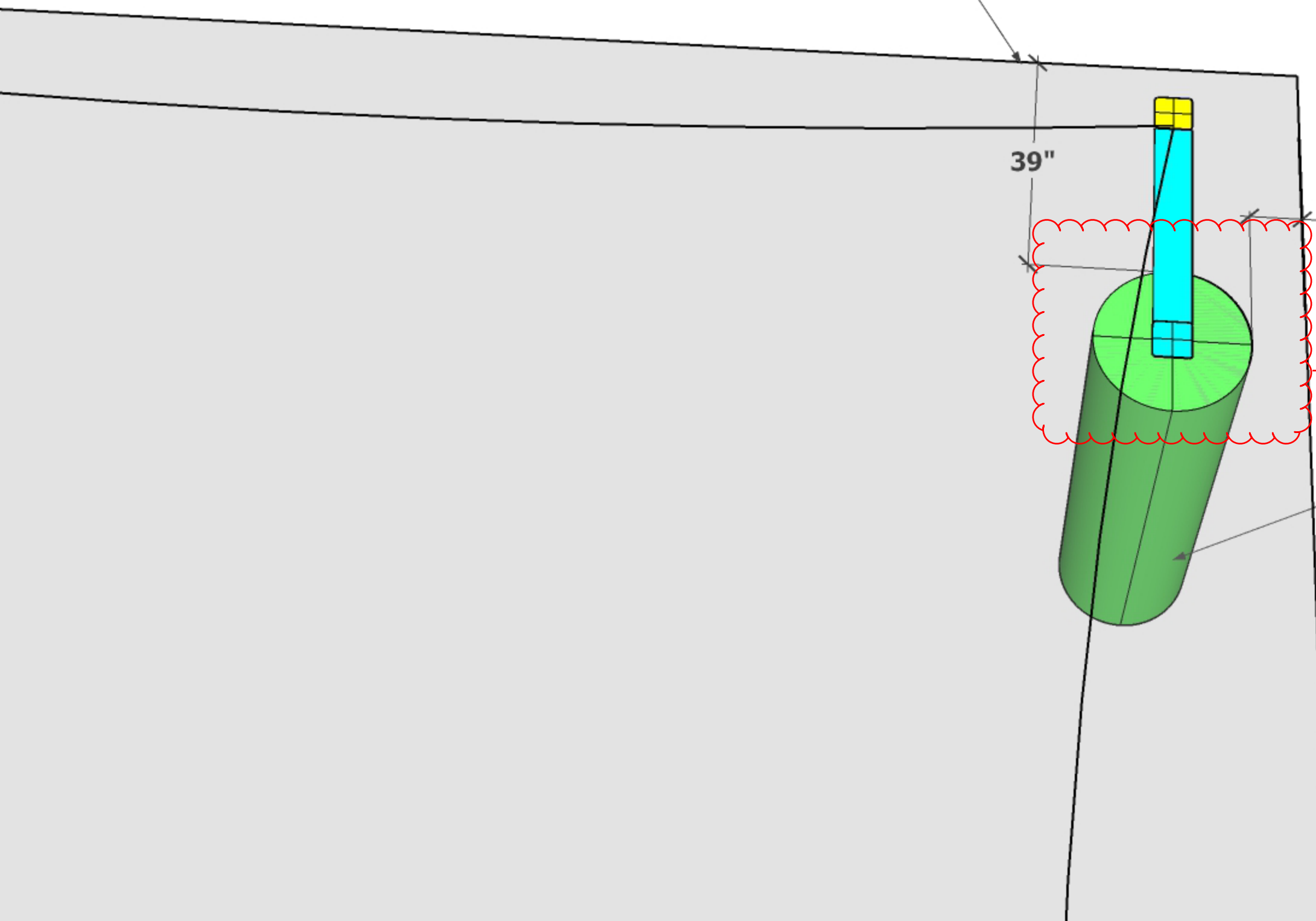

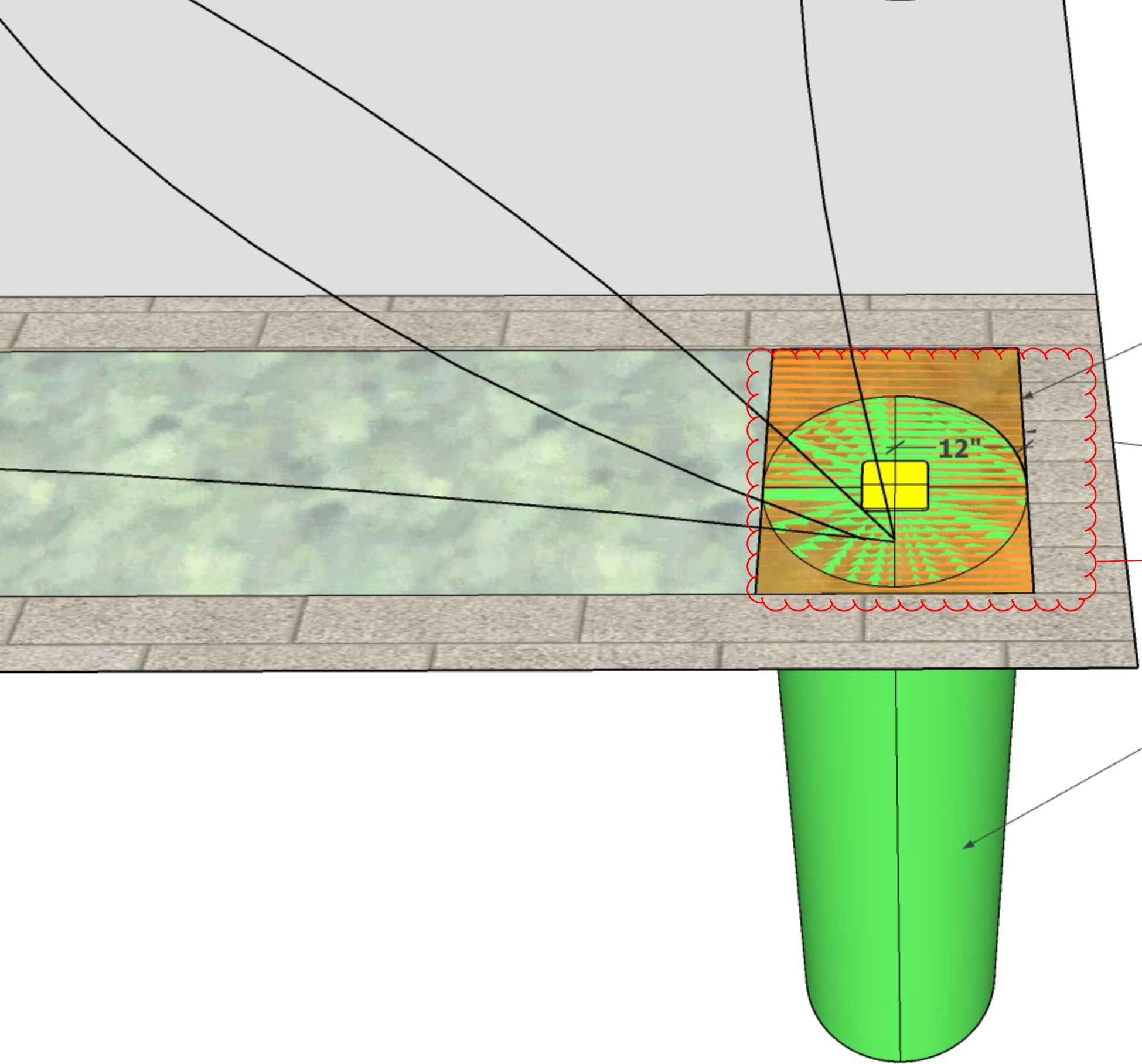

**24" wide x 8" thick tie beam per engineer detail "Tie Beam Section C-C"**

**Tie beam starts 4" bellow existing planter wall. 8" thick tie beam ontop of 7'-6" deep pile**

**7'-6" x 2' DIA FOOTING 3000 PSI CONCRETE PER ENGINEER DETAIL "FOOTING SECTION B-B"**



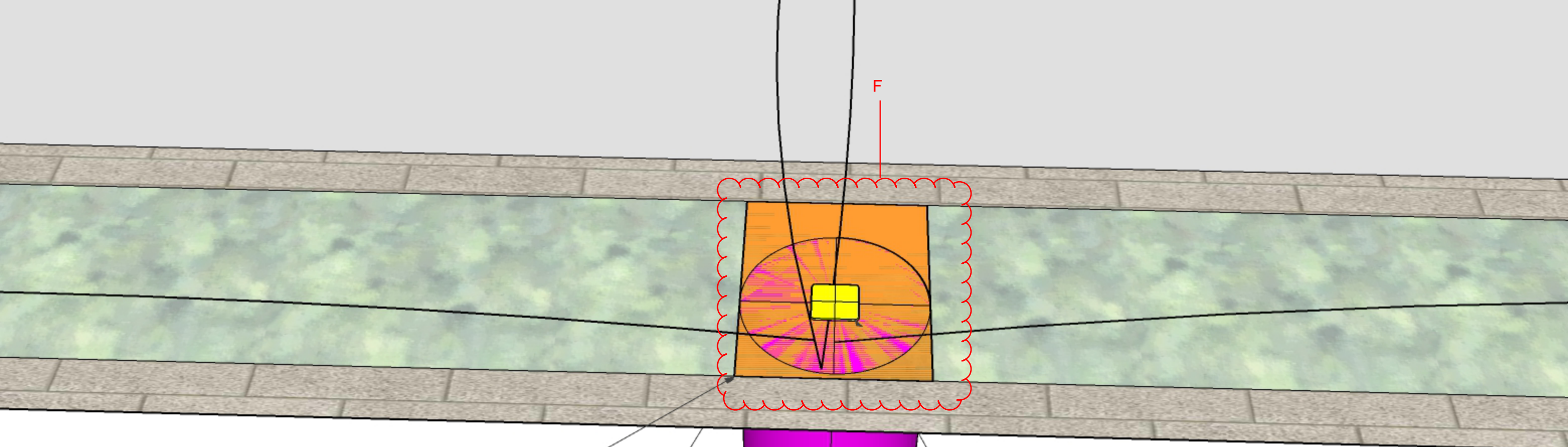

Tie beam starts 4" bellow existing planter wall. 8" thick tie beam ontop of 9'-0" deep pile

24" wide x 8" thick tie beam per engineer detail "Tie Beam Section C-C"

align with post across at building

9'-0" x 2' DIA FOOTING 3000 PSI CONCRETE PER ENGINEER DETAIL "FOOTING SECTION B-B"

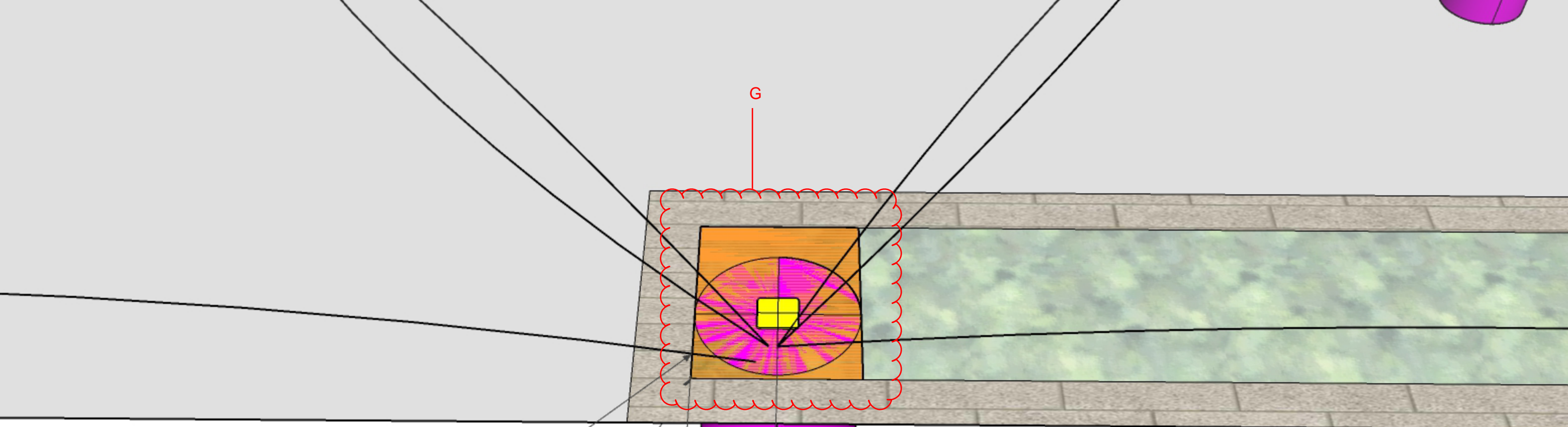

**24" wide x 8" thick  
tie beam per engineer  
detail "Tie Beam Section C-C"**

**Tie beam starts 4" bellow  
existing planter  
wall. 8" thick tie beam  
ontop of 9'-0" deep pile**

**12"**

**9'-0" x 2' DIA  
FOOTING 3000 PSI  
CONCRETE  
PER ENGINEER DETAIL  
"FOOTING SECTION B-B"**

# GATE

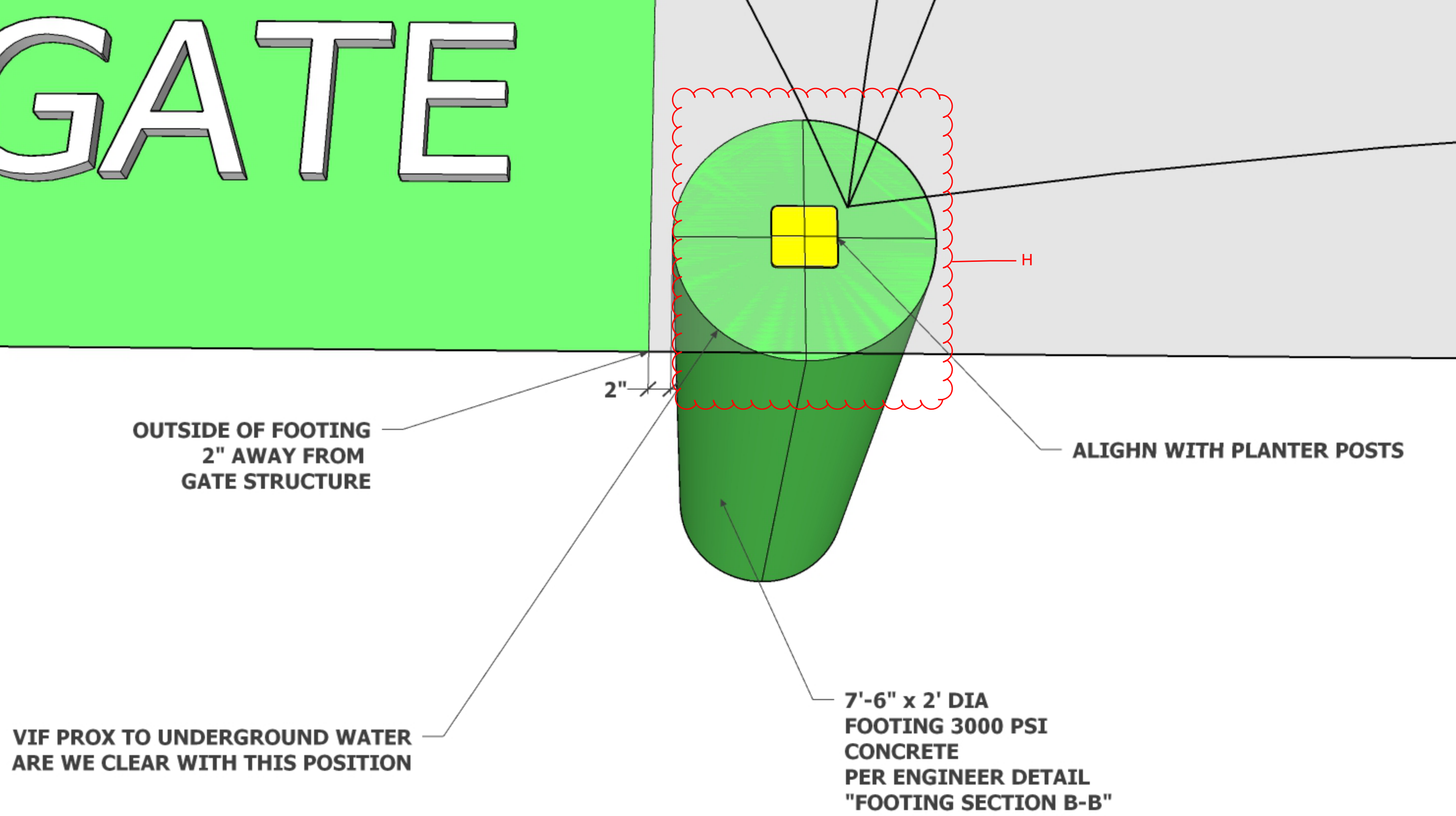

OUTSIDE OF FOOTING  
2" AWAY FROM  
GATE STRUCTURE

VIF PROX TO UNDERGROUND WATER  
ARE WE CLEAR WITH THIS POSITION

7'-6" x 2' DIA  
FOOTING 3000 PSI  
CONCRETE  
PER ENGINEER DETAIL  
"FOOTING SECTION B-B"

ALIGN WITH PLANTER POSTS



bracket attached to wall  
per engineering detail  
"CMU Wall Elevation A-A"

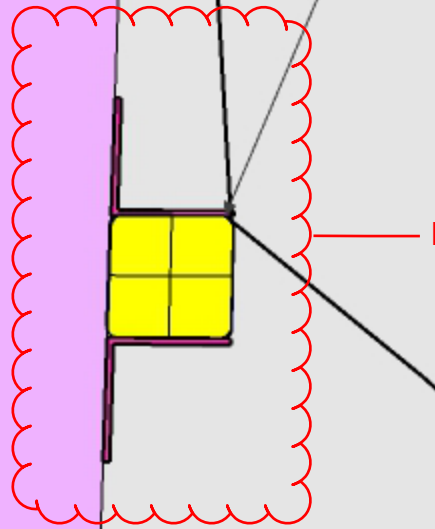

Provide proper paint protection from water damage to steel

Steel column per plan

L6x6x5/16 x 8" long angle @ 16" o.c. with (2)-5/8" dia. through bolts each side of column

CMU wall per plan

(E) 4" concrete slab V.I.F.

1/2" x 9" x 14" base plate with (2)-1/2" dia. x 2.75" embedment Hilti Kwik Bolt TZ2 wedge anchor with 1-1/2" non shrink grout  $f_c=4000$  psi.

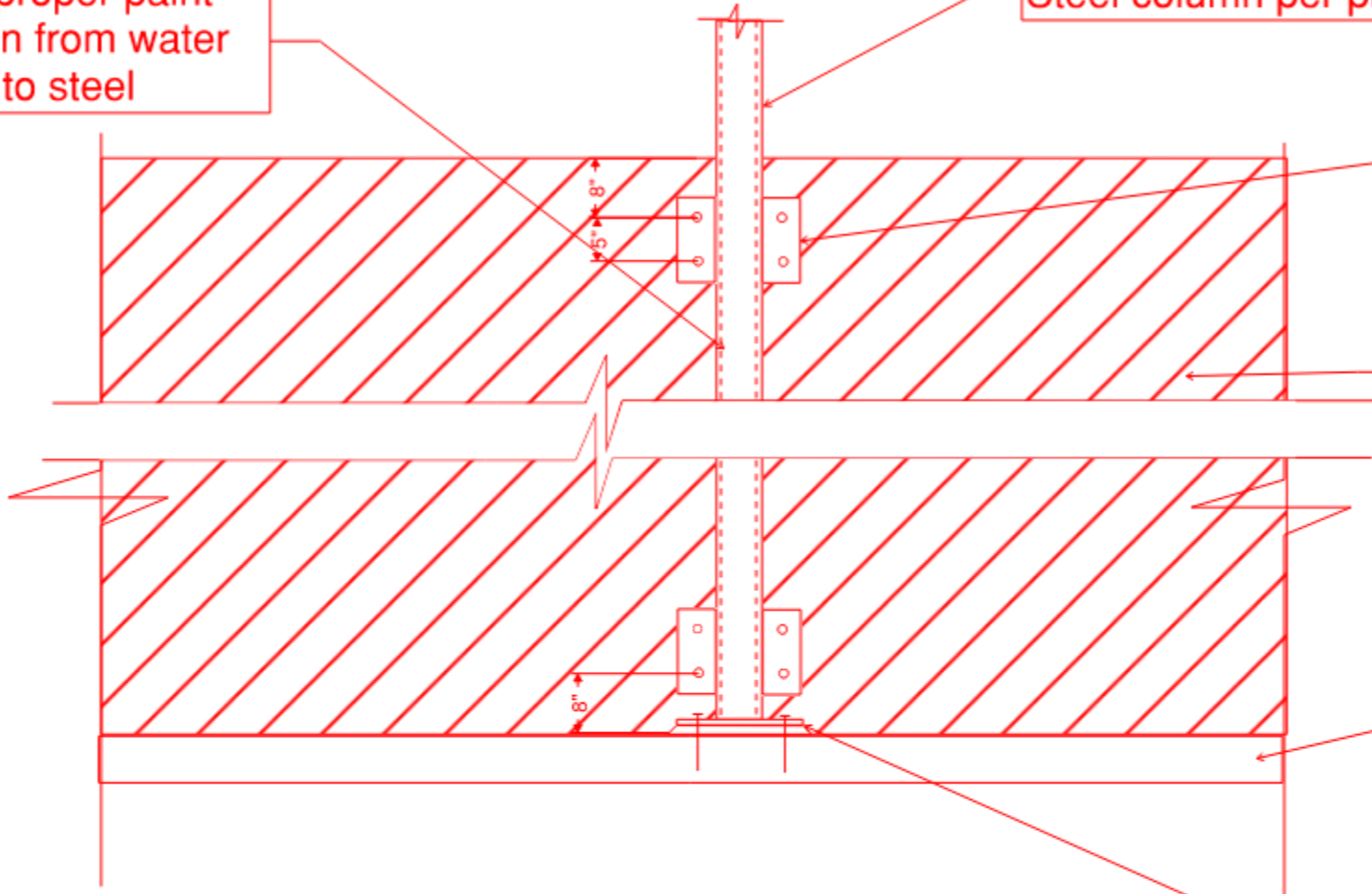

## CMU Wall Elevation A-A

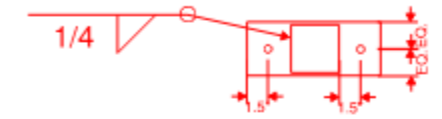

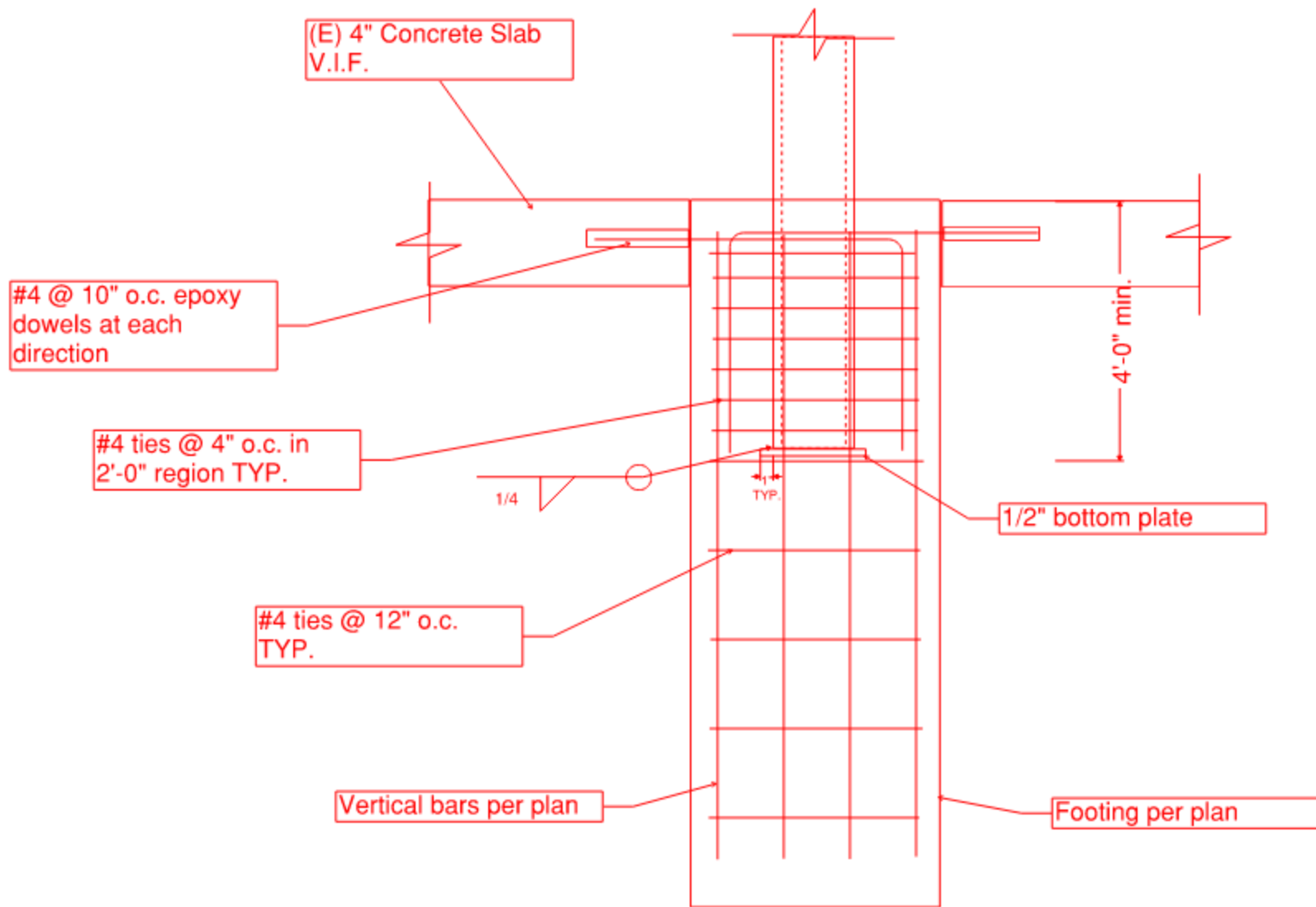

## Footing Section B-B

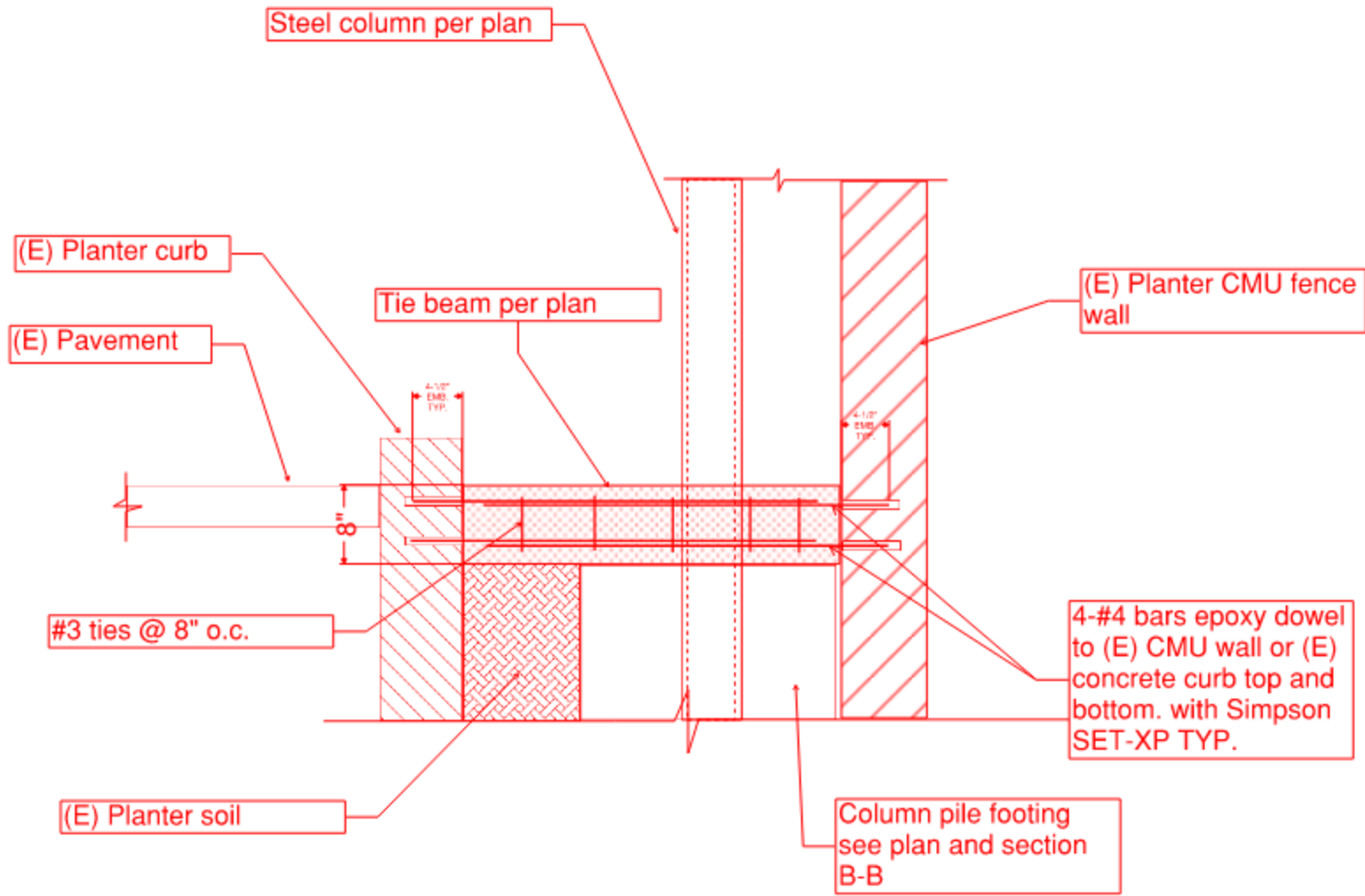

## Tie Beam Section C-C