



Board Agenda Item #:	II C: Action Item
Date:	March 29, 2021
To:	Magnolia Public Schools – Board of Directors
From:	Alfredo Rubalcava, CEO and Superintendent
Staff Lead:	Erdinc Acar, Chief Academic Officer
RE:	Magnolia Public Schools In-person Reopening Plans

Recommendation

Staff is recommending the full board to approve Magnolia Science Academy 1,2,3,4,5,6,7,8, SA and SD to reopen in-person in compliance with health and safety orders, community expectations and corresponding law and regulations on April 12, 2021.

Introduction

In compliance with health and safety orders, community expectations and corresponding law and regulations, MPS has been preparing to open its campuses for in-person instruction. MPS has Reopening Task Forces that has been meeting since May 2020 with a goal of reopening our school campuses for the continuity of high quality of education with the safety and protection of all in mind with the guiding principles of equity and access for all, inclusive process with voices and choices and commitment to MPS values of innovation, connections and excellence. The Task force has been working on the Reopening Plans based on the frameworks and guidelines from multiple agencies including CDPH, CDE, LACOE, OCDE, SDCOE and related county health departments, keeping up with research based on best practices, national and international experiences and engaging all stakeholders in the process by collecting the relevant information and data for an informed and sound decision.

Background

On March 5, 2021, Governor Newsom signed AB 86 providing \$2 billion for safe in-person instruction support and \$4.6 billion for expanded academic, mental health and social-emotional support. It provides \$2 billion as an incentive for schools that have not already done so to offer in-person instruction beginning April 1, starting with the earliest grades. The legislation also allocates \$4.6 billion for all school districts regardless of whether they meet the timetable in the “Safe Schools for All” plan. To get the extra funding, districts and charters are expected to provide in-person instruction to a range of students with special needs — such as those in special education or others in “prioritized groups,” such as English learners, homeless students or those in foster care, and even “disengaged” students.

Approved by Governor on June 29, 2020, Senate Bill 98 also regulates Distance Learning and requires compliance with daily live instructions and instructional minutes, connectivity and devices, grade level content, academic supports, special Education, ELD instruction/assessment, daily live interaction with certificated employees and peers. If daily live interaction is not feasible as part of regular instruction, the governing board or body of the local education agency shall develop, with parent and stakeholder input, an alternative plan for frequent live interaction that provides a comparable level of service and school connectedness.

Based on the guidance and orders, on July 23, 2020, MPS Board approved schools to start virtually with full Distance Learning models for MSAs 1-8 on August 18, 2020, for MSA-Santa Ana on August 10, 2020 and for MSA-San Diego on August 31, 2020. The schools have been providing Distance Learning per January 14, 2021 updated CDPH's COVID-19 and Reopening In-Person Learning Framework for K-12 Schools in California.

In October 2020 when MPS sites reconvened for in person small groups of instruction, the MPS Home Office began to implement wellness checks and surveillance testing as indicated in the board approved health & safety policy and IIPP (Injury and Illness Prevention Plan) addendum for COVID-19. The Health and Safety Team has actively supported schools in preparing their facilities for a safe reopening through site visits over the summer, COVID-19 case follow ups and tracking, town hall meetings with all stakeholders and having weekly meetings with the school site administrators for ongoing support and training. Furthermore, MPS streamlined communication to all employees for COVID-19 vaccination.

In the March 11, 2021 regular meeting, MPS board also approved schools to reopen as in-person and hybrid format while allowing students and families to continue with full distance learning options. Since then, the schools have surveyed parents for their commitment for in-person instruction. Based on the surveys, 1,368 students (about 45% of respondents) chose in-person instruction.

Attached plans lay out specific reopening plans and protocols for Magnolia Public Schools in the areas of Curriculum and Instruction, Health and Safety, Operations, Social Emotional Support and Family and Community Engagement to reopen all schools for in-person instruction starting April 12, 2021.

Magnolia schools reopening timeline:

- May 5, 2020 - ongoing: Org-wide Reopening Task Force Meetings
- June 4-18, 2020: Reopening Town Hall Meetings for parents
- June 18-28, 2020: Parent, Student and Staff Surveys (Proposed Options)
- June 23-24, 2020: Leadership Retreat
- July 9, 2020: Board Meeting: Reopening Decisions and Plan of Action - Presentation of the preliminary plans
- Board approval of the reopening of MPS (July 23, 2020)
- Final Board approval of the reopening plans with policy and protocol updates (August 6, 2020)
- Schools reopened for instruction. MSAs 1-8 – August 18, 2020, MSA-Santa Ana – August 17, 2020, MSA-San Diego – August 31, 2020

- March 5-19, 2021- Town hall meetings and parent surveys.
- Schools plan to reopen in-person instruction starting April 12, 2021.

Budget Impact

Schools that open will be receiving additional funding per SB 86. \$6.6 billion in state funding – \$2 billion in incentives to expedite the return to school and \$4.6 billion to address Covid’s impact on learning – will be apportioned, mainly via the Local Control Funding Formula.

Attachments

1. MPS Reopening Plans with presentation



REOPENING OF MPS SCHOOL CAMPUSES

2020-2021 School Year

TABLE OF CONTENTS

INTRODUCTION	3
GUIDELINES	4
RESOURCES	4
INSTRUCTION	5
Considerations.....	5
Recommendations and Decisions.....	7
Next Steps.....	8
Distance Learning Version 2.0.....	8
Mitigation of Learning Loss - MTSS/Tiered Interventions/Support.....	9
MPS Wide Digital Programs.....	9
HEALTH AND SAFETY	10
Considerations.....	10
Recommendations and Next Steps.....	11
Next Steps.....	15
OPERATIONS	16
Considerations.....	16
Recommendations and Next Steps.....	19
Next Steps.....	20
SOCIAL AND EMOTIONAL SUPPORT	23
Considerations.....	23
Recommendations and Next Steps.....	24
Next Steps.....	25
Resources.....	25
FAMILY AND COMMUNITY ENGAGEMENT	26
Considerations.....	26
Recommendations and Next Steps.....	26
Next Steps.....	27
Resources.....	27

INTRODUCTION

MPS has a school Reopening Task Force that has been meeting since May 5th with a goal of reopening our school campuses for the continuity of high quality of education with the safety and protection of all in mind with the guiding principles of equity and access for all, inclusive process with voices and choices and commitment to MPS values of innovation, connections and excellence.

Current Task Force members are comprised of the home office staff, school site admins, teachers, and board members. The Task force has been working on the Reopening Plans based on the frameworks and guidelines from multiple agencies including CDE, LACOE, OCDE, SDCOE and related county health departments, keeping up with research based on best practices, national and international experiences and engaging all stakeholders in the process by collecting the relevant information and data for an informed and sound decision.

This document is aimed to present the board and our communities with our considerations and plans for reopening of our schools.

GOAL: *Reopen school campuses for the continuity of high quality of education with the safety and protection of all in mind as soon as possible.*

OUTCOME/DELIVERABLES

- Guide the process of reopening activities
- Recommend solutions for challenges
- Develop a plan and protocols
- Create to-do lists and checklists

GUIDING PRINCIPALS

- Equity and access for all
- An inclusive process with voices and choices
- Commitment to MPS values of Innovation, Connections, Excellence

APPROACH

Create a task force to guide the reopening process with a plan of action. Consistent with the local health education agencies in LA, SD and OC, CA Governor's directions, CDE recommendations, and authorizer feedback. Create a timeline of tasks that can be shifted when necessary.

GUIDELINES

1. [California's Roadmap to Modify the Stay-at-Home Order](#) 6 indicators for reopening
2. [Federal Guidelines for Opening Up America Again](#)
3. [CDC reopening and cleaning guide](#)
4. LA County Health Dept recommendations [ROADMAP TO RECOVERY - A Phased Approach to Reopening Safely](#)
5. [CA Guides for business reopening](#) - May 12, 2020
6. [CA State Reopening Resilience Map](#) - May 18, 2020
7. [CDC Schools reopening decision tool](#) - May 12, 2020
8. [AEI A Blueprint for Back to School](#) - May 12, 2020 - General recommendations
9. [Guidance for Schools from World Health Organization](#) - May 14, 2020 - General recommendations
10. [McKinsey COVID-19 Reconsiderations for Reopening Schools Webinar](#) - May 14, 2020 - Comprehensive guides with best practices from different countries
11. On May 19, 2020, the U.S. Centers for Disease Control and Prevention (CDC) released updated [guidelines](#) for reopening and resuming schools and child care facilities during the coronavirus pandemic.
12. [LACOE Reopening Framework](#) - May 27, 2020
13. NEW! [CDPH COVID-19 INDUSTRY GUIDANCE: Schools and School- Based Programs](#) - June 5, 2020 updated July 17, 2020
14. NEW! [CDE Reopening Guideline Stronger Together](#) - June 8, 2020
15. SDCOE Guide
16. OCDE Guide

RESOURCES

1. LACOE COVID-19 RESOURCES [Parents/Families](#) | [Educators](#) | [Administrators](#)
2. National Center for School Crisis and Bereavement - [COVID-19 Pandemic Resources](#)
3. [National Child Traumatic Stress Network](#)
4. NWEA - [The COVID-19 slide: What summer learning loss can tell us about the potential impact of school closures on student academic achievement](#)
5. [CDPH Guidance for K-12 Schools in California Jan 14/2021 update](#)
6. [CA Safe Schools for All Readiness Hub](#)
7. [CCEE Guidebook for Reopening](#)

INSTRUCTION

CONSIDERATIONS

The Instruction workgroup consisted of 19 original members and had multiple considerations to keep in mind as in our discussions about reopening planning. At the forefront of all recommendations is the **safety** of all stakeholders, as well as, ensuring we are providing a **high-quality, equitable education for all students**. We began our work by analyzing the instruction section of the Los Angeles County Office of Education Planning Framework for the 2020/2021 School Year. This framework gave us best practices, resources and planning implications to consider as we develop the MPS reopening plans. After reviewing the framework and determining which elements apply to our program, we gathered further **information from our stakeholders, via surveys and town hall meetings**. This was a vital component in order to make the best recommendations possible. In addition, we ensured we remained apprised of all state, county, and local orders and guidance. We researched promising practices from other countries and states that have already reopened schools to learn more about the practices that have led to successful reopenings and what did not work. We also needed to consider collaboration time for departments/grade levels to review and plan curriculum once the **"essential standards"** are released to teachers. Teachers will need to **identify key stories, math lessons, grammar units, social studies units, and science concepts** to maximize instructional time. Everything taught needs to be intentional, specific and planned out. Below is a summary of the topics we covered and a brief description of options considered for each topic.

Delivery of Instruction: During these conversations, we addressed and discussed all reopening options from a traditional school day (5 days a week in person) to full distance learning. In looking at the data and research, it became clear that we could not safely reopen schools using a traditional model. We do not have the space on our campuses to house all students five days a week and ensure proper social distancing guidelines. After listening to feedback in the town hall meetings and reviewing the stakeholder survey results, it was evident we needed to provide options to our families. Due to health concerns for students or family members, about 20% of families need a **distance-learning option**. Therefore, we determined it was important to provide that option to families in addition to a hybrid model that would allow for some in-person instruction, as distance learning will not work for 100% of our students. We considered several hybrid options; a split day model, a two-cohort model, a five-cohort model, and a staggered schedule model. After looking at feasibility of some options and impact on student learning, we determined that **a two-cohort model would best support** our students' learning and provide the safest option for in-person instruction.

Individual School Flexibility: In creating recommendations, we had to consider that our schools are vastly different based on geographical location. With this in mind, we discussed if it would be in the best interest of our schools and students to allow some flexibility in scheduling options so that our schools can base reopening plans on local contexts. In our discussions, the importance of having some consistency in reopening plans was stressed by numerous taskforce members as we are all Magnolia Public Schools.

Grading Policy: One area of concern and deliberation was the grading of student work. Due to the pandemic and emergency switch to remote learning in the Spring, in accordance with CDE guidelines, MPS adopted a no-harm grading policy for students. With this policy, there were instances of students not fully engaging or completing work. This led to concerns that students were not able to participate in a high-quality educational program. In our discussions, we looked at various grading models such as the no-harm grading system, mastery-based grading, and our MPS-adopted grading policy. Pros and cons of each grading system were considered and multiple points of view were heard and examined.

Teacher Teaching Assignments: In consideration of teacher workload and ensuring the delivery of high-quality instruction, the taskforce considered what teachers' teaching assignments should consist of since we would not be in a traditional instructional delivery model. We considered whether the same teacher should teach in both the hybrid model of instruction and the distance learning model, or if we should separate teaching assignments and have in-person teachers and distance, learning teachers. Pros and cons of each model were discussed as well were staffing and budget constraints. The idea of organization-wide distance learning teachers was even explored in determining creative solutions to constraints.

Assessments: Learning loss and identifying unfinished learning is a crucial element to planning and delivering high-quality instruction. As such, the task force reviewed our current assessment cycle and researched how we could conduct assessments in a remote learning environment if need be. We determined that both our NWEA Measures of Academic Progress Assessments (MAP) and Smarter Balanced Interim Assessments (SBAC) can be administered in both in-person and remote learning environments in a secure manner. With this information, we revisited our assessment cycle and discussed how we could best use our existing resources to identify learning needs and support student learning.

Attendance: Based on Senate Bill 98 requirements, daily attendance will be taken and it will be based on synchronous and asynchronous learning. MPS will ensure that a weekly engagement record is completed through our student information system for each pupil documenting synchronous or asynchronous instruction for each whole or partial day of distance learning, verifying daily participation and tracking assignments. Each school will document daily participation for each pupil on each school day in whole or in part, for which distance learning is provided. A pupil who does not participate daily in either in-person instruction or distance learning shall be deemed absent. SB 98 requires that instructional time for distance learning is based upon the time value of assignments as determined and certified to, by an employee of the LEA who possesses a valid certification. Schools will have documentation of the minimum required instructional minutes for each day and bell schedules will reflect that.

Daily participation includes but is not limited to, evidence of participation in online activities, completion of regular assignments, completion of assessments, and contacts between employees of the School and pupils or parents/guardians. Evidence of any one of these in the tracked assignments is "daily participation".

The minimum school day for K is 180 minutes; for grades 1-3 it is 230; for grades 4-12 it is 240 unless the students are in grades 11-12 and taking UC, or CSU classes for credit or any student taking a community college course for credit in which case it is 180. If the student is ONLY doing distance learning, the total time value of the assignments will meet or exceed the minimum requirements listed here. If the student is engaging in in-person instruction, the minimum amount of time in distance learning is determined by the total minimum school day (listed above by grade level) reduced by the time scheduled under the immediate physical supervision and control of a credentialed employee.

If a student misses 3 school days or 60% of the instructional days in a school week which would trigger required tiered reengagement strategies per distance learning and attendance policy/procedure.

Student Rotations: For scheduling purposes, we discussed the idea of secondary students rotating classes or remaining in the same classroom and teachers rotating. We discussed the logistics of each option as well as health and safety concerns with both options. We examined the various elements we need to consider for each option, such as if teachers were to rotate classrooms would need equivalent technology and resources, supplies to allow for teachers

to easily rotate between classrooms, disinfecting between class periods, how to properly supervise students during teachers' rotations, and teacher's thoughts about the idea of rotating classes. If students were to rotate to different classes, we discussed how passing periods might look, how schedules would need to allow for disinfecting between each group, how do we ensure students abide by social distancing guidelines in open areas, and how supplies would be handled. During this discussion, safety and social distancing guidelines were continuously discussed to make the best recommendation possible.

RECOMMENDATIONS AND DECISIONS

Delivery of Instruction: Based on survey input and feedback from staff, parents, students, and the Re-Opening Task Force, it is our recommendation that schools reopen using a two cohort hybrid model, along with a full distance learning option. We are estimating that 10-20% of families will select full distance learning; the remainder of students will be split into two cohorts. This will effectively lower our class sizes to allow for the recommended distance between students to be maintained during instruction. Cohort A will attend school on Monday and Tuesday for in-person instruction. Cohort B will attend school on Thursday and Friday. Wednesday will be allotted for deep cleaning and sanitization between cohorts, as well as staff meetings, teacher PD and planning time. We also recommend that Wednesdays are utilized to provide additional in-person instructional support to students most in need, such as ELs and students with IEPs. All students will receive high-quality distance learning on the days on which they do not attend school for in-person instruction.

Individual School Flexibility: We recommend that all MPS schools follow the hybrid model (as discussed above) for reopening schools. However, we understand that local contexts, including staffing, student and family needs, and requirements from various authorizers, and well as co-located campuses, will impact schedules differently at each site. Therefore, we recommend that each MPS school be given flexibility in terms of daily schedules and course offerings.

Grading Policy: We recommend that all MPS schools continue to follow the grading policy as has been adopted in the MPS student-parent handbook. Although schools will not be able to reopen in the traditional manner, we are no longer in an emergency situation which requires a do-no-harm policy. Furthermore, as families will have the option to self-select either full distance learning or a hybrid model, we believe that it is in the best interest of our students to return to the accountability of our grading system.

Assessments: We recommend that all MPS schools continue to utilize NWEA MAP testing to regularly assess for both learning loss and recovery. While all MPS schools utilize MAP testing at least twice per year (Fall and Spring), we recommend an additional Winter assessment so that schools have multiple data points with which to monitor students' learning loss and recovery. Furthermore, we recommend that all MPS schools continue to administer the Math and ELA Smarter Balanced Interim Assessments according to the testing schedule organized by the Home Office Academic Team.

Student Rotations: In order to minimize potential virus exposure and maximize social distancing, we recommend that students remain stationary in their classrooms, and (at the secondary level) that teachers rotate between classrooms to provide instruction. Students should be assigned seats in their classrooms and should stay seated as much as possible in order to maintain appropriate social distancing.

NEXT STEPS

Magnolia Public Schools will continue providing students and families with high quality and standards based education programs with new reopening orders, guides and requirements. In compliance with the legislation and regulations, MPS will offer in-person instruction to the greatest extent when it is safe and recommended. As of July 23, 2020, all Magnolia Public Schools will reopen with the **Distance Learning** only model based on the CDPH and Governor's order and MPS Board of Governance actions.

All teachers are expected to provide high quality learning programs using the proposed curricula and strategies by updating the curriculum maps and pacing guides to cover the content and standards necessary to complete the planned course syllabus per CDE guidance.

Rigorous distance learning

Under newly enacted state law, MPS will provide:

- Devices and connectivity so that every child can participate in distance learning.
- Daily live interaction for every child with teachers and other students.
- Class assignments that are challenging and equivalent to in-person instruction.
- Targeted supports and interventions for English learners and special education students.

In-Person Re-Opening Criteria (CDPH)

MPS may reopen for in-person instruction at any time if they are located in a local health jurisdiction (LHJ) that has not been on the county monitoring list within the prior 14 days.

Distance learning includes both virtual and non-virtual means of providing education. We need to be mindful of the fact that not all of our learners will have access to the internet and may not be familiar, comfortable or successful with digital learning. As educators we will continue differentiating the curriculum, instruction and assessment for all of our learners addressing their needs, interests and backgrounds.

Distance Learning Version 2.0

Home office and school teams work in strengthening and improving the Distance Learning plans and programs as this mode of learning will continue being part of our offerings for the 2020-21 School Year. Specifically;

- Adding new instructional programs and effective approaches,
- Addressing and mitigating the learning loss due the Covid-19 closures
- Providing staff with new professional developments on Distance Learning. Continue capacity building for flipped learning/classroom and hybrid and blended learning best practices and tools
- Establishing set class schedules and meeting times
- Improving engagement, attendance and communication means
- Training parents and students
- Improving grading and attendance systems
- Improving assessments and monitoring

Per Ed. Code, § 43503(b), **MPS Distance learning** will include the following minimum components:

- (1) provision of **access for all** pupils to connectivity and devices adequate to participate in the educational program and complete assigned work;

- (2) **content aligned to grade level standards** that is provided at a level of quality and intellectual challenge equivalent to in-person instruction;
- (3) **academic and other supports** designed to address the needs of pupils who are performing below grade level, or need support in other areas;
- (4) **special education, related services**, and any other services required by a pupil's individualized education program;
- (5) **designated and integrated instruction in English language development**; and
- (6) **daily live interaction** with certificated employees and peers for purposes of instruction, progress monitoring, and maintaining school connectedness.

Daily live interaction shall occur as follows:

- MPS Distance Learning Portal
- Google Classroom, Zoom Meeting, Google Hangouts and other live meeting tools
- Email contact
- Phone contact
- Student work submitted in other communicative ways
- Student Square communication tool
- Parent Square communication tool
- In-person as permitted by the public health orders

Mitigation of Learning Loss - MTSS/Tiered Interventions/Support

MPS has been using a multi-tiered systems of support approach and has introduced Universal Design for Learning to meet students' instructional needs. As we look to mitigate learning loss due to COVID-19, MPS will continue to use this multi-tiered approach alongside Universal Design for Learning to ensure equity and access for all students.

All students in tier 1 receive high-quality, standards-aligned instruction, differentiated to meet their needs. Students are assessed on a periodic basis to identify struggling learners who need additional support. These tier 1 supports are usually conducted as just-in-time interventions in response to formative assessment data from grade-level assessments. In addition, when planning instruction, teachers will use the Universal Design for Learning approach to ensure all lessons are accessible to **all students** and embed necessary supports so that **all students** can be successful.

Students needing additional support are provided with tier 2 interventions which provide increasingly intensive instruction to further meet students' needs. Specialized classes, such as Power ELA and Power Math, offer small group instruction in a supportive environment to help students overcome their learning loss. Formative assessments are utilized to identify gaps in learning and teachers adjust instruction accordingly. Extended school day offerings, such as after school enrichment and Saturday programs are also offered to students who need this additional support.

Students still needing additional support receive intensive interventions that target the students' skill deficits for the remediation of existing problems and the prevention of more severe problems. These tier 3 interventions are highly individualized and customized based on the needs of the individual student.

MPS Wide Digital Programs

Clever, **MPS's Single Sign** on for online programs, will be used as a backbone for access to all digital programs. All MPS teachers are expected to use **Google Classroom** to facilitate teaching and learning activities. **MPS's Distance Learning Portal** will be enhanced to allow teachers and students for ease of access and effective communications.

Pedagogy and Practices for Continuity of Learning

- Be present as the instructor for live sessions
- Work as a group with colleagues
- Focus on active, authentic and project-based learning
- Chunk content into smaller pieces
- Give multimedia options for assignments
- Whole group and small group instruction
- Hold "Office Hours"
- Keep up with pacing and maps
- Do effective time management

HEALTH AND SAFETY

CONSIDERATIONS

The Health & Safety workgroup consisted of 7 members and had various aspects to keep in mind. Each school site has special considerations like available space and collocation regulations. For this reason, Principals were looped in to be able to express concern regarding the special circumstances at their site. Because many of the items overlapped, the Health & Safety workgroup also worked closely with the Operations workgroup when making considerations.

The following recommendations are based on the following documents released by the State & Local county agencies:

- [LACOE County Schools: Rising to the Challenge of COVID-19](#)
- [CDE Stronger Together Guidebook for the Safe Reopenings of CA Public Schools](#)
- [CA Dept of Public Health COVID 19 Industry Guidance: Schools & School-based Programs](#)
- [San Diego School District Reopening Plan](#)
- [LA County Department of Public Health Orders as of June 18th 2020](#)
- [LA County K-12 School Reopening Protocol](#)
- [CA Department of Public Health COVID-19 Industry Guidance: Schools and School Based Programs](#)
- MPS Health and Safety Plan for COVID-19 (Provided)
- MPS Illness and Injury Prevention Program (Provided)

The topics of consideration include the following:

- Classroom Safety & Distancing, Social Distancing, & Entering School
- Personal Protective Equipment (PPE), Face Coverings, & Handwashing
- Health Office, Health Office Staffing, Immunization Requirements
- Health Chain of Command, Health Training
- Meals (Distribution)
- School Disinfecting Procedures & Ventilation (Added by MPS)
- Illness at School, Home Isolation, Exposure to COVID-19, COVID-19 Testing
- Students and Staff with Underlying Health Conditions
- Communication, Safety Information
- Child Care

While we may be proceeding with a Distance Learning module at the start of the school year, the following preliminary recommendations are for when students return to campus. These recommendations may be updated to include guidance from legal counsel, updates in federal or local ordinances, and changes in the instructional model.

RECOMMENDATIONS AND DECISIONS

Classroom Safety & Distancing, Social Distancing, & Entering School

1. Survey school site facilities to see how many staff/students can be on site while practicing social distancing
2. Calculate how many students can fit into the classrooms by accommodating the 6ft of distance recommended by the CDE/CDPH
 - H&S Recommendations: Remove all other classroom furniture to make space for more student desks. Split students into 2 cohorts so that there are only 10-16 students per class. If students are sitting closer than 6ft student individual student desk dividers are recommended.
3. Decide whether students or teachers would be traveling class to class
 - H&S Recommendations: Have students stay in 1 classroom for as many classes as possible. Considerations would need to be made for specialty classes like art and computers.
4. Devise a plan to maintain social distancing in the following areas/scenarios:
 - Students entering the school site- See next step
 - Meal Distribution- See "Meal Sub Section"
 - Students & teachers in the classroom- See step 2 for recommendations
 - Passing periods
 - Elementary only - Recess
 - PE classes
 - Common Work Spaces
 - School Site visitors
 - Student dismissal
 - H&S Recommendations: For all scenarios keep physical distancing in mind. Ensure students, staff, and visitors are equipped with the right PPE to prevent the spread of the disease. Remove furniture and direct traffic to discourage people congregating.
5. Devise a streamlined procedure for students to safely enter the school site.
 - H&S Recommendations: Identify main entry and exit points on campus and make other entrances unavailable to all staff and students. Funnel staff, students and visitors through the main entry point to be able to conduct health, mask, & hygiene checks as they enter. Ensure that enough staff members are stationed and entry points to prevent backup.
6. Share social distancing plans and procedures with all stakeholders
 - H&S Recommendations: Send reminders of social distancing protocols & procedures throughout the year in all newsletters.

Personal Protective Equipment (PPE), Face Coverings, and Handwashing

1. Receive PPE being distributed by local counties which could include (numbers reflect total items being distributed by LACOE) :
 - No-touch thermometers for every school and childcare facility totaling more than 47,000;
 - Face shields for every teacher and child care provider, totaling approximately 2.4 million;
 - More than 14 million cloth face coverings for staff and students;
 - More than 16 million disposable masks;

- 123,000 N95 masks for school-based health professionals, including those interacting with symptomatic students; and
 - 143,000 gallons of hand sanitizer.
2. Establish a minimum standard of PPE based on the supplies distributed by local counties
 - H&S Recommendations: School sites to maintain minimum standard of PPE based on the items distributed by the state when buying supplies with the option of upgrading when allowed by budget
 3. Work with the Operations workforce to research PPE and disinfecting supplies options and pricing that will maintain the MPS-wide minimum standards. PPE & disinfecting supplies to include:
 - Cloth Face Coverings
 - Disposable Masks
 - N95 Masks
 - Face Shields
 - Hand washing/Hand Sanitizer Stations
 - Student Desk Dividers
 - Office/ Teacher Desk barriers
 - Curtains/Folding dividers if needed
 - Thermometer
 - Gowns
 - Gloves
 - Signs
 - Disinfecting supplies
 - Hand Sanitizer
 4. Investigate limitations and special considerations for co-located school sites
 5. Using the Operations "Reopening Purchases" Google doc, keep track of PPE or additional supplies purchases made.
 6. Develop an inventory system to keep track of PPE being distributed & have a storage space to keep items bought in Bulk
 - H&S Recommendations: Set up an inventory system at the MPS- level and school site level to keep track of items obtained by the county and bulk purchases made.
 7. Assign specific PPE to certain stakeholders to understand what PPE is distributed to whom. H&S Recommends the following:
 - Students have cloth masks distributed and disposable masks available if needed. Students with Health conditions may be able to use the face shield under certain circumstances.
 - Teachers and regular school staff should have cloth masks distributed and disposable masks available if needed. They will also be given face shields to be able to work with students that may be hard of hearing or have another underlying health condition that requires full facial visibility.
 - Health Professionals and Staff members that may be exposed to symptomatic students should be given N95 masks, gowns, gloves, thermometers, and face shields on top of the cloth and disposable masks available.
 - In house Janitorial staff should be provided PPE needed to be able to handle the disinfectants that they are working with. This may include gowns, face shields, gloves, and goggles on top of the cloth and disposable masks available.
 - Visitors and 3rd party vendors will be required to be masked but will have disposable masks available

8. Develop a PPE MPS-wide policy that is in line with all federal, state, and local county orders.
 - Student policy will be added to the Parent/Student handbook and be sent as an addendum.
 - Staff and 3rd party vendor policy should be developed by legal and the HR department.
9.
 - Visitor policy will be in line with local ordinances
 Develop a hygiene routine for staff and students to follow
 - H&S Recommendations: routine should include frequent handwashing and encouraging proper PPE use and hands to be kept away from face.

Health Office, Health Office Staffing, Immunization Requirements

1. Survey School Sites to see if they currently have a Health Office and Isolation Space
 - H&S Recommendations: Each site should have a dedicated Health Stations for the Health care professional to work out of and an isolation area where symptomatic students or staff can wait to be picked up. The isolation area should be in an area where others do not enter or pass through frequently.
2. Set up health & Isolation Station with proper PPE equipment & first aid supplies
 - *See PPE section for rec
3. Ensure Health Station has proper staffing
 - *See step 1 of Health Chain of command for recommendations
4. Ensure all students have complied with the state's Immunization requirements
 - H&S Recommendations: Immunization requirements have not been waived and there will be no grace period for students not in compliance. Office staff will continue to work with the accountability department to ensure compliance. Once the school year gets rolling and schools are set up with a healthcare professional, re-assign Immunization responsibilities (Compliance, communications, reporting) to the person responsible for the health station/ health care professional if feasible.
5. Develop Isolation Station policy & procedures
 - *See Illness at school for rec.

Health Chain of Command, Health Training

1. H&S Recommendation: Hire a healthcare professional
 - MSA-1-7, SA, & SD will be hiring a CNA through Cross Country Education. The CNA will be on campus for 6 hours a day throughout the week. These sites will also have a School Nurse (RN) available for 4-8 hours a week.
 - MSA-8's site will be sharing a School Nurse (RN) with their collocated sites who will be on campus daily.
2. Identify a school site team to help develop and execute school site safety plans and emergency procedures.
 - H&S Recommendations: Include your Principal, DOS, and healthcare professional in the development of a school safety plan that includes COVID considerations like exposure and outbreak procedures.
3. Train school site administrators on:
 - H&S Recommendations: Have your School Nurse (RN) lead all health related trainings which may include topics like:
 - Identifying COVID signs and Symptoms
 - How to isolate students who are symptomatic
 - How to screen students & visitors entering the school sites
 - Hygiene procedures
 - EpiPen administration
 - First Aid Procedures
4. Promote new policies and procedures to students and parents
 - See Communications Section for additional details and recommendations

Meals (Distribution)

1. Develop a grab & go pick up procedure with food vendors for students during Distance Learning.
2. Survey school sites to see what areas are available to serve lunch when students are on campus for hybrid model
 - H&S Recommendations: Have students eat in an outdoor area while complying with physical distancing. If no outdoor space is available, have students eat in their classroom.
3. Develop a Meal distribution plan with SFA and the meal vendor to accommodate a hybrid instructional model.
4. Research the meal distribution plans available for MSA-5 & 8 (who use LAUSD as their meal vendor) for Distance Learning and Hybrid instructional models.

School Disinfecting Procedures & Ventilation

1. Deep Clean all school sites before reopening to the public
2. Ensure each school site has proper HVAC filters
 - H&S Recommendations: Using filters with a filter rating of at least MERV13
3. Ensure each school site has Janitorial staff
 - H&S Recommendations: Ensure Janitorial Staff is capable of completing new disinfecting procedures. Schools may have a back up cleaning service available in case school site Janitorial staff is out.
4. H&S Rec: Train school site staff on disinfecting procedures
 - All staff should learn what disinfecting wipes/sprays can be used around students and people with health conditions
 - Janitorial staff to receive extra OSHA training on current disinfecting and ventilation guidelines
5. Devise ways to limit contact with frequently touched surfaces
6. Establish a cleaning and disinfecting schedule to avoid under/over use of cleaning products
7. Devise ways to make PE and Recess cleaner
 - H&S Recommendations: Limiting use of playground equipment. Reformat PE classes to be more focused on individual exercises

Illness at School, Home Isolation, Exposure to COVID-19, COVID-19 Testing

1. Follow the MPS Injury and Illness Prevention Program (IIPP) and the MPS Health and Safety Plan for COVID which outlines testing, exposure, and isolation procedures.
2. Create a tracking system for both Students that keeps track of people showing symptoms and how long they've been isolated for
 - H&S Recommendations: Health Professional to keep track of student illness.
3. Conduct wellness checks as students and staff enter the school.
 - H&S Recommendations: Have Healthcare Professional (CNA) lead wellness checks on campus
4. Ensure that staff conducting wellness checks are well equipped with PPE.
 - See PPE sections for recommendations
5. If a student is symptomatic during wellness check, or throughout the day insure the school follows the isolation procedure outlined in MPS Health & Safety Plan and disinfecting procedures outlined in the IIPP plan.

Students and Staff with Underlying Health Conditions

1. Identify students and Staff with underlying Health conditions and each school site and share with your healthcare professional
2. Develop a plan to accommodate those students/staff
3. H&S Recommendations: Nurse, SPED Case manager, HR, and Principal to develop individualized plans for each student with a health condition. The school site Command team, which may include the MPS HR department, School Nurse, and Principal, will make accommodations for staff members as requested.

Communication, Safety Information

1. Work with Family and Community Engagement workgroup to create Magnolia wide messages which will include the following talking points:
 - General safety guidelines for students and parents
 - General Safety guidelines for staff
 - Importance of attendance and when to stay home. Options available to students absent due to isolation.
 - Procedures on how to reenter school/work
2. Work with Family and Community Engagement workgroup, and school Principals, and admin teams to create create Site Specific messages that include the following talking points
 - Check in/ drop off procedures
 - Any collocation special considerations
3. Create org wide generic messaging that would notify staff and students of an outbreak to use if needed throughout the year
4. Continuously provide all stakeholders with updates and reminders of new policies and procedures both at the MPS-wide and school site level.

Child Care

Afterschool programs are different for each school site. Some sites that have an outside vendor have been in contact with their afterschool program to see options are available for next school year. As more information is available we will be populating this item

NEXT STEPS

Next steps would include the Health & Safety team to continue to work with school sites and Operations work force to ensure the following:

1. Classroom Safety & Distancing, Social Distancing, & Entering School
 - Ensure sites have a proper entrance/exit procedure that considers the time it takes to do health screening
 - Classrooms and common workspace areas have been reconfigured at every school site to meet the 6ft physical distancing guidelines.
 - Identify storage for unused materials
2. Personal Protective Equipment (PPE), Face Coverings, & Handwashing
 - Ensure all schools have proper PPE and PPE training before school starts.
3. Health Office, Health Office Staffing, Immunization Requirements
 - Each school site has worked with the health care professionals to develop safety plans and procedures with COVID-19 Considerations.
 - School sites continue to monitor Immunization compliance
4. Health Chain of Command, Health Training
 - The health Chain of command is established
 - The School Nurse (RN) conducts the necessary trainings at the sites
5. Meals (Distribution)
 - Continue to work with Schools in Action and BetterForYouMeals to create a streamlined meal distribution procedure for students on campus and who may be distance learning at each school site.
 - Ensure MSA- 5 & 8 work with their collocated sites to create a meal distribution plan

6. School Disinfecting Procedures & Ventilation (Added by MPS)
 - Work with the operations team to ensure school sites are deep cleaned, HVAC filters are upgraded, and each school site has proper janitorial support.
7. Illness at School, Home Isolation, Exposure to COVID-19, COVID-19 Testing
 - Ensure school sites have an adequate health and Isolation station.
 - Ensure that each school develops site specific exposure and outbreak procedures.
8. Students and Staff with Underlying Health Conditions
 - Identify students with special health conditions at each school site and have the health care professionals along with the school site command team come up with accommodations if needed.
9. Communication, Safety Information
 - Work with The Family and Community Engagement workgroup and school site parent engagement teams to ensure updated information is disseminated to parents in a timely manner.
10. Child Care
 - School sites will reach out to their third party vendor to discuss after school options in the upcoming schools year.
 - School sites that run after school programs in house would need to see if after school care is still feasible and come up with a plan to ensure student and staff safety.

OPERATIONS

CONSIDERATIONS

The operations workgroup included the Human Resources & IT departments, principals, deans, and the home office legal department as the permanent members. Throughout the past 2 months we occasionally had other workgroups such as Health & Safety and Family and Community Engagement workgroups to collaborate and make decisions together. Operations workgroup considered the LA County's guidelines and the subtopics as well as the tenets provided by the county.

Our main focus was to maintain effective and efficient operations by following best practices in the following areas and related subtopics identified by the workgroup members. Some areas or subtopics may be under the control of other workgroups are defined in parentheses.

1. Facilities
 - Outside facilities
 - Campus Physical restrictions / limitations
 - Class sizes
 - Drop off/Pick up
 - Passing periods, recesses, breaks
 - Elementary School sites' concerns
 - Visitors
 - Office space
 - Nurses Office Space/Area for sick students (Health & Safety workgroup leads this)
 - Spacious Room need for student & admin/service provider meetings

2. Budgeting and financial operations (working closely with the Finance department and the CEO for budgeting, revenue follow up and making necessary purchases)
 - Locating the revenues assigned by the state and federal government such as CARES Act & ESSER Funds
 - Meetings with each site admin to go over their 2019-20 and 2020-21 budgets to set aside funds for the safe reopening of our schools
 - Identifying the funds covered by the CARES Acts and ESSER Funds
 - Reconciliations against 2019-20 & 2020-21 budgets
 - Following up with the Accounts Payable of the Finance department for the purchases of all items in order to have a safe reopening
 - Multiple meetings with the principals and Health & Safety workgroups to identify the needs
 - Locating vendors
 - Defining the supplies to be sent by the counties
 - Making the purchases either for each school or via bulk orders
 - Planning for or purchasing the needs emerging with COVID-19
 - Defining the need for nurses for each site
 - Budget arrangements
 - Decision to go with a vendor for nurses
 - > Identifying a vendor
 - Substitute budget arrangements for each site
 - Increased needs for IT peripherals, IT needs are budgeted respectively
 - Data ports for socioeconomically disadvantaged families
 - 1 Chromebook for each staff and student
 - Health & Safety
 - PPE items such as masks, face shields, hand sanitizers etc.
 - Medical supplies such as thermometers,
 - Facility related items such as portable water fountains, shade structures, extra lunch benches, hand sanitizing stations, classroom student desk dividers, sneeze guard and plexy guards for offices etc.
3. Human Resource Services
 - 2020-21 Employee Handbook
 - Telework Policy is added
 - Health Safety and Security Policy is updated due to COVID-19
 - Accident and Incident Reporting is updated due to COVID-19
 - Worker's Compensation
 - Consulted with the service provider on steps when there is COVID-19 exposure
 - Policies/guidelines when the employee is feeling sick
 - The schools were referred to the County Public Health guidelines
 - HR Department will continue to monitor and update according to the most recent guidelines
 - 2020-21 Training
 - Mandatory training
 - The Home Office team has worked on finalizing the complete list for all trainings to be assigned through Safe Schools. This year there will be additional trainings related to COVID-19

3. Communication

- COVID19@magnolia email group generated in order to make sure all MPS home office staff are on the same page for any concern or update coming from school sites.
- The U.S. Department of Labor announced new action regarding how American workers and employers will benefit from the protections and relief offered by the Emergency Paid Sick Leave Act and Emergency Family and Medical Leave Expansion Act, both part of the Families First Coronavirus Response Act (FFCRA).
 - The policy is implemented in MPS HRIS system
 - The implementation and the policy have been shared with all MPS employees

4. Nutrition (This section was handled by the Health & Safety Workgroup, below are operations perspectives only)

- Meal distributions
 - Signages to be prepared in case of a Hybrid or full in person learning
 - 6 ft markers
 - Certain warning signs to make sure students are aware of COVID-19 social distancing guidelines.
 - In case of full distance learning, continuation of the free food provision services on the MPS school grounds identified before or on the co-located sites' certain identified sections. Working with the mps Board approved vendors for this.
 - Providing extra handwashing and hand sanitizing stations around lunch and breakfast areas
 - The Health & Safety team is working with our meal vendor, SFA, and school sites to:
 - Discuss our meal delivery and distribution options.
 - Survey school sites to see what areas are available to serve lunch when students are on campus to see if students can eat outdoors as recommended by the Health & Safety team.
 - Acquire additional materials needed for the type of lunch distribution procedure being used that will not be provided by SIA or Better4You meals
 - Develop a grab & go pick up procedure with food vendors for students who are not on campus due to Distance Learning.

5. Transportation (MPS does not provide transportation, however below are operations workgroup suggestions)

- Field Trips & large assemblies not happening until Stage 5
For the students with disabilities, in case the IEP of the student requires transportation the site must accommodate the needs.

6. Technology infrastructure

- Chromebook and Data Ports/Hotspots distribution to each Individual Student or families in need of access to internet
 - Each Chromebook tagged and monitored through AssetWorks, GoGuardian
 - Safety:
 - Goguardian: Monitor usage of chromebook at school and home
 - Creation of Individual Student Emails (allow access to chromebooks)
 - The email accounts are assigned after enrollment.
 - Chromebook sign in
 - It helps for communications
 - Helps for online activities through GoGuardian
 - Helps access to Google Education Suite
 - Managed by IT Managers and Home Office IT Director

- Wireless Access Check for parents through surveys conducted by the Instructions and Family and Community Engagement workgroups
 - Purchasing of new hotspots
 - Contracted with T-Mobile
 - Distribution of hotspots
- Teacher Training for Specific Platforms
 - Teacher trainings are provided:
 - Through the vendor and/or manufacturer (if equipment), developer (software), usage best practices (consultants)
 - The school admin, teacher, or IT personnel who are savvy to provide the training.
- Cleaning & disinfection
 - Special wipes
 - Special disinfectants

7. Other key systems and services

- Before and After school programs: MPS site is the fiscal agent for this grant, which means the school gets the money and decides on how to utilize the funds under the ASES guidelines
 - MPS Currently benefits from 21st Century After School Grants. These are
 - ASES Grants for K-8: MSA 1, MSA 3, MSA 5, MSA 7, MSA 8, MSA Santa Ana, MSA San Diego are the MPS sites receiving these funds.
 - MSA 1, MSA 3, MSA 5, MSA 7, MSA San Diego are working with board approved vendors to get after school services. The Board approved vendors are ThinkTogether Inc., arc, YMCA. These vendors are working on plans to provide the after school services online during the distance or hybrid learning era.
 - MSA 8 & MSA Santa Ana do not work with a vendor but run the after school services internally
 - ASSET Grants for High Schools: ThinkTogether, Inc is the fiscal agent for these grants, which means the vendor gets the funding for the specific site and plans with the site for provisioning after school programs for that site using these funds.
 - Currently MSA 1, MSA 2, MSA 3, MSA 4 do have the ASSET After School Programs with ThinkTogether, Inc. ThinkTogether, Inc., already working on the plans for each site to provide after school services during the pandemic.

RECOMMENDATIONS AND DECISIONS

The operations workgroup collaborated with the Health and Safety, and started purchasing the items suggested by the Health and Safety workgroup along with the principals and home office staff. Below is the summary of all purchased items as of 7/28/2020 for all MPS sites:

1. **2019/20 & 2020-21 Funds Used for all these purchases, eligible purchases to be reimbursed via CARES Act (ESSER funds, see 4-b below)**
 - Total dollar amount of the purchased items: **\$279,678.04**
 - MERF Ordered \$187,733.19 of this amount as bulk order to be distributed to schools
2. **List of items/services purchased/contracted:**
 - **PPE:** (Hand Sanitizers, Face Shields- Masks (Disposable, KN95, Cloth Face Covering), Gloves
 - **Facility:** Front Office & maintenance Supplies, disinfecting services, towels, wipes, soaps, sneeze guards/barriers
 - **IT Materials:** Hot spots, from T-Mobile, Chromebooks from HP

- **Medical Supplies:** Thermometers, no touch or infrared
- **Nurse Services:**

This expense is not part of the dollar amount mentioned above in section 1-a. Home Office contracted with a third party vendor for having 1 CNA (Certified Nursing Assistant/Health Care professional) for each site under an RN (Registered Nurse), except MSA-Bell (LAUSD PSC School Nurse).

- The costs of these CNAs and RN is budgeted under each site, not reflected above. The total cost for all sites is expected to be around \$522,500 for a school RN for 40 hours per week for MSA 1 thru 7 and 8 hours per week for each of MSA-SA and MSA-San Diego plus 1 CNA on every campus for 6 hours per day every school day.
- MPS admins decided to continue with the contracted CNAs and RNs although it is Distance Learning now until further notice, because we wanted to make sure we have systems in place before the school starts hybrid or in person.

3. Further plans:

- Leasing storage(s) in case we need to store the extra desks at the school sites due to possible hybrid instructional model. This is postponed until we have clear guidelines from the state to go back to Hybrid or in person instruction on site.
- 2-sided or 3-sided student desk and meeting room separators. These are for possible for the hybrid instructional model.
- Contracting -more- companies for continuous deep cleaning & janitorial services and printing posters re:COVID-19

4. Received/Receivables

- LACOE, SDCOE, and OCDE will send 2 months worth of PPE supplies to LA, SD, and OC MPS schools. We are awaiting confirmation from the SDCOE. OCDE already sent PPEs to MSA SA.
- MPS is expected to receive approximately \$ 1.16 million under the CARES act (ESSER) for all MPS sites. The COVID-19 related expenditures will be reconciled against the funds coming from CARES Act.
- We also are expecting Learning Loss Mitigation Funds for our sites as of September 1st, 2020. Funds to be used for COVID-19 related expenses until December 30, 2020 unless Congress extends the deadline.

NEXT STEPS

Below is the list of all items needed for reopening schools, entered by each school site admins. Items may be purchased in bulk orders or per each site. Some items already purchased as shown above, some will be purchased soon. The word "sample" is used in case the principal of the site requested a sample first before ordering. Others saw the samples at the home office, or at an MPS site or in the email message & placed their orders. "PLANNING" in the chart means schools are still researching that item.

1	PLEXI PROTECTIVE BARRIER-CONSUMABLES	MSA 1	MSA 2	MSA 3	MSA 4	MSA 5	MSA 6	MSA 7	MSA 8	MSA SA	MSA SD	TOTALS
	2 SIDED STUDENT	sample	200	150	Sample	Sample	Sample	275	25	sample	Sample	650
	3 SIDED STUDENT	sample	300	200	Sample	Sample	Sample	55	280	sample	Sample	835

2	BARRIERS-OFFICE & TEACHERS	MSA 1	MSA 2	MSA 3	MSA 4	MSA 5	MSA 6	MSA 7	MSA 8	MSA SA	MSA SD	TOTALS
	PLEXY BARRIER PROTECTION 1 SIDED (LARGE)	2	2	2	2	2	1	1	3	0	1	16
	PLEXY BARRIER PROTECTION 2 SIDED (OFFICE)	3	6	2	1	0	2	0	4	0	5	23
	PLEXY BARRIER PROTECTION 2 SIDED (TEACHERS)	0	22	0	0	15	0	0	0	0	0	37
	DEFLECT-O ACRYLIC	0	0	0	0	0	1	0	0	0	0	1

3	CLOTH MASKS	MSA 1	MSA 2	MSA 3	MSA 4	MSA 5	MSA 6	MSA 7	MSA 8	MSA SA	MSA SD	TOTALS
	STYLE 4 REGULAR	0	0	0	0	0	0	0	0	0	0	0
	STYLE 4 EAR LOOP, ADJUSTABLE	1,000	1,000	1,000	300	650	300	60	1,000	1,000	80	6,390
	STYLE 5 (GOES AROUND THE HEAD)	0	0	0	0	0	0	10	0	0	0	10
	NECK GAITERS ELEM ONLY	0	0	0	0	0	0	600	0	600	0	1,200
												0

4	DISPOSABLE MASKS	MSA 1	MSA 2	MSA 3	MSA 4	MSA 5	MSA 6	MSA 7	MSA 8	MSA SA	MSA SD	TOTALS
		10,000	10,000	10,000	2,500	5,000	2,000	10,000	10,000	10,000	5,000	74,500

5	GOWNS	MSA 1	MSA 2	MSA 3	MSA 4	MSA 5	MSA 6	MSA 7	MSA 8	MSA SA	MSA SD	TOTALS
		10	12	10	10	10	10	10	10	10	10	102

6	GLOVES (1 CASE 1,000 Pairs)	MSA 1	MSA 2	MSA 3	MSA 4	MSA 5	MSA 6	MSA 7	MSA 8	MSA SA	MSA SD	TOTALS
	XL	2	2	2	1	2	1	1	1	2	0	14
	L	4	5	4	2	3	1	3	2	3	3	30
	M	4	5	4	2	3	1	2	3	3	7	34
	S	1	3	4	1	3	1	2	2	5	1	23

7	SIGNS (PLANNING)	MSA 1	MSA 2	MSA 3	MSA 4	MSA 5	MSA 6	MSA 7	MSA 8	MSA SA	MSA SD	TOTALS
												0

8	DISINFECTING SUPPLIES	MSA 1	MSA 2	MSA 3	MSA 4	MSA 5	MSA 6	MSA 7	MSA 8	MSA SA	MSA SD	TOTALS
	Screen Cleaners											0
	disinfectant spray/ fog machine/UV light											0

9	HANDWASHING/SANITIZING STATIONS (PLANNING)	MSA 1	MSA 2	MSA 3	MSA 4	MSA 5	MSA 6	MSA 7	MSA 8	MSA SA	MSA SD	TOTALS
	Handwashing stations	1										0
10	GOGGLES	MSA 1	MSA 2	MSA 3	MSA 4	MSA 5	MSA 6	MSA 7	MSA 8	MSA SA	MSA SD	TOTALS
			5		0	0	0	2	5	2		14
11	FACE SHIELDS	MSA 1	MSA 2	MSA 3	MSA 4	MSA 5	MSA 6	MSA 7	MSA 8	MSA SA	MSA SD	TOTALS
	REUSABLE	6	40	40	0	0	0	0	55	80	40	261
12	NO TOUCH THERMOMETERS	MSA 1	MSA 2	MSA 3	MSA 4	MSA 5	MSA 6	MSA 7	MSA 8	MSA SA	MSA SD	TOTALS
		6	5	5	2	5	2	1	1	0	10	37
13	HAND SANITIZER	MSA 1	MSA 2	MSA 3	MSA 4	MSA 5	MSA 6	MSA 7	MSA 8	MSA SA	MSA SD	TOTALS
		20	20	20	6	16	0	20	20	20	20	162
14	N95 MASKS	MSA 1	MSA 2	MSA 3	MSA 4	MSA 5	MSA 6	MSA 7	MSA 8	MSA SA	MSA SD	TOTALS
		5	5	5	5	5	5	5	5	5	5	50
15	OUTDOOR FURNITURE (PLANNING)	MSA 1	MSA 2	MSA 3	MSA 4	MSA 5	MSA 6	MSA 7	MSA 8	MSA SA	MSA SD	TOTALS
	LUNCH TABLES		0									0
	LUNCH BENCHES		0									0
16	FACILITY	MSA 1	MSA 2	MSA 3	MSA 4	MSA 5	MSA 6	MSA 7	MSA 8	MSA SA	MSA SD	TOTALS
	SHADE STRUCTURE		0									0
	STORAGE SHED	3	1	3								7
17	IT MATERIALS	MSA 1	MSA 2	MSA 3	MSA 4	MSA 5	MSA 6	MSA 7	MSA 8	MSA SA	MSA SD	TOTALS
	CHROMEBOOKS	250	0	200	40	250	120	85	255	0	0	1,200

The Home Office started conducting site visits to further identify needs of the sites in person based on the the new [LACDPH reopening protocols for K-12 schools Health Officer Orders](#). Below is the chart showing the visit dates. As of 7/28 MSA Santa Ana, MSA 1 and MSA 2 first visits completed and next visits will be in a month to complete the COVID-19 readiness checks.

	9-10	10-11	11-12	12-1	1-2	2-3	3-4
7/24/2020	MSA SA	MSA SA	MSA SA				
7/28/2020	MSA 1	MSA 1	MSA 2	MSA 2			
7/29/2020			MSA 8	MSA 8			
7/30/2020	MSA SD	MSA SD	MSA SD				
7/31/2020	MSA 3	MSA 3					
8/4/2020	MSA 7	MSA 7	MSA 5	MSA 5			
8/6/2020	MSA 4	MSA 4	MSA 7	MSA 7			

SOCIAL AND EMOTIONAL SUPPORT

1. LACOE COVID-19 RESOURCES [Parents/Families](#) | [Educators](#) | [Administrators](#)
2. National Center for School Crisis and Bereavement - [COVID-19 Pandemic Resources](#)
3. [National Child Traumatic Stress Network](#)
4. CDC, [Learn to prevent ACEs](#)

CONSIDERATIONS

The collective trauma stakeholders have experienced during these unprecedented times requires a lot of reflection and care. The ability to effectively cooperate as a team is due in great part to the natural ability Magnolia Public Schools (MPS) stakeholders bring in meeting the needs of students and putting the children's care and well being at the forefront of decision making. The transition into the new school year will not be one without its expected and unexpected challenges but it is essential we remember that every person experiences traumatic events differently. Everyone has been impacted by Covid-19 in some way, if not by the virus directly but from the impacted economy, housing and social distancing measures.

As with any tragic or traumatic event it is important to acknowledge each individual's feelings and emotions that present themselves as a part of the psychological reactions during a disaster. There needs to be an understanding that some people will need more time than others to find their own routine in the "new" normal. Our responsibility as educators and leaders is to help students and employees get back to as best a regulated state that brings comfort and provides for the brain what it needs to be at its optimal learning state and while caring for the needs of the whole person. We acknowledge that the optimal care we expect to provide to our students cannot exist in a silo and fundamental collaboration with staff, school partners and the overall community is foundational to our goal. We understand our staff will need support transitioning as well and MPS has incorporated resources and strategies to help. The parents/caregivers who have taken on the biggest transition and workload during the sudden change in learning environment will also need ongoing support as well and through the ongoing work of the social emotional reopening work group we are prepared to fill the need.

The considerations the workgroup are divided into three stakeholder groups while leveraging Connection, Communication and Care for each group:

Staff

- Re-entry plan for onboarding staff following the transition from traditional in-person teaching and learning to virtual instruction
- Accommodations for underlying health conditions
- Understand the needs of our staff specific to schools sites (i.e. child care, housing, etc.)
- [Psychological First Aid \(PFA\)](#) Training for school leaders and staff
- Trauma informed care and resiliency training
- Mental health and wellness resources and activities for staff
- Each staff member should be informed of their role during distance learning and identify appropriate staff who will help students with specific needs outside of the typical roles i.e. Teachers are not counselors but can listen and then connect students to the school counselor or administrators for additional support with needs

Students

- In addition to the considerations for staff with basic needs for re-entry plan
- Keeping in mind the various experiences students have encountered while away from school sites
- Understanding every students circumstances are different and some may not want to share challenges but will demonstrate some behaviors as a form of communication
- Monitor if basic needs are being met and meet them, remember H.A.L.T- Are you Hungry, Angry, Lonely, Tired?
- Teach and model expectations for students related to distance learning, do not assume students will translate traditional classroom expectations in the virtual setting
- Applying PFA as needed with the model Listen, Protect, Connect, Model and Teach
- Consistent check-ins and leveraging points of contact to create stability

Parents/Caregivers

- In addition to the considerations for staff and student basic needs for re-entry
- Keeping lines of communication clear and open with families to minimize confusion or frustration
- Opportunities to leverage connection with consistent check-ins and leveraging points of contact
- Updating organization chart, families should know roles and responsibilities for staff especially in the virtual setting
- Connection to resources specific to meet the needs of parents/caregivers
- Understanding that housing and financial circumstances may have changed for families and providing the housing survey more than once in the school year

RECOMMENDATIONS AND DECISIONS

The recommendations by the workgroup are to continue to work with staff to develop trauma informed care training and prepare our staff with the knowledge and tools to support as smooth a re-entry plan as possible for the overall learning community.

Work with students closely to teach, model and reinforce virtual learning expectations and supportive environments. Check-in with parents/caregivers to understand the needs they may specifically have and how staff can help.

The team vetted many resources in accordance with various county and local district framework models as well as our own existing resources and reference materials. Below are the recommendations that will guide our next steps.

- Survey Stakeholders to understand and measure Mental Health and Wellness Readiness
- Training for Staff, Parents/Caretakers related to Trauma Informed Care (ACEs) and Promoting Resilience,
- Critical frontline staff reading: *The Deepest Well*, Dr. Nadine Burke Harris
- Teaching Lessons/Curriculum for Students: Cultivate an environment of self-regulation and emotional control, Zones of Regulation curriculum
- Create and sustain opportunities promoting a culture of care: Emphasis on Mental Health and Wellness activities (School Calendar)
- List of Supportive resources for Staff, Students, and Parents/Caretakers
- Community partnerships for a sustainable network of care
- School Safety Plan revisions, in addition include Illness and Injury Prevention Plan (IIPP)
- Crisis Management Team focus on Mental Health and Wellness (Additional PFA Training)
- Clear referral process for students experiencing a crisis or in need of mental first aid
- Sustainable mentorship and motivation programs for staff and students year round
- Growth mindset lens supporting all students through equitable and inclusive Positive Behavior
- Interventions Supports (PBIS) and restorative practices

NEXT STEPS

The MPS reopening task force subcommittee workgroup will continue to finalize tasks in preparation for reopening and launching our stakeholders into a successful school year.

The workgroup has prioritized:

1. Completing mental health and well-being readiness survey for all stakeholders, including protocols with an ideal launch window two weeks prior to school orientation dates for every grade level
2. Creating one pagers of support for stakeholders where they can access local resources to help with social emotional support.
3. House the vetted and critical resources for all stakeholders on an online easy to access format such as the [Additional Resources Padlet](#)
4. Create an implementation plan for curriculum focused on self-regulation and emotional control organization wide, *The Zones of Regulation*, Leah M. Kuypers
5. Provide professional development for staff focused on trauma informed care and resilience supported by school psychologists and mental health professional at each school site

RESOURCES

The resources the group is compiling can be referenced in the tasklist for the reopening and ongoing operations of social emotional supports linked above and [here](#).

FAMILY AND COMMUNITY ENGAGEMENT

CONSIDERATIONS

The Family and Community Engagement Subcommittee utilized the Los Angeles County Schools: [Rising to the Challenge of COVID-19 A Planning Framework 2020-21](#) School Year Volume One - May 27, 2020, by the Los Angeles County Office of Education as the bases for the considerations, recommendations, and next steps.

1. This document focused on several aspects of the reopening process: a) Engage All Families in Decision-Making, b) Specific and General supports for families, c) Multi-faceted communications methods through different platforms, d) Multi-dimensional messaging, e) Establish and inform families on protocols and procedures, f) incorporating flexibility, g) budget implications, h) supporting families when children are ill/ at home, i) and creating effective communication systems.
2. While reviewing the Rising to the Challenge to the Covid-19 document, we determined which items were: a) being done already, b) what needs to be done, c) and what is the priority level for each task.
3. The items that were prioritized and needed to be done were examined by the re-opening task force Family and Community Engagement Subcommittee and prioritized.

RECOMMENDATIONS AND DECISIONS

The goal of the Family and Community Engagement Subcommittee was to ensure all students, staff, and community members remain involved and supported by following best practices in the areas of:

- Ensuring effective communication systems
- Engaging stakeholders
- Using community partnerships
- Other key systems and supports

Below are recommendations The Family and Community Engagement Subcommittee considered:

Will we have additional town hall meetings for parents?

Recommendation from Subcommittee:

1. Yes, the Family and Community Engagement committee recommends an additional town hall meeting prior to the start of the 2020-21 academic school year to present the Magnolia Public Schools board approved reopening plan.

Can we enable the "interpretations" feature on Zoom for future family stakeholder meetings (ie. townhalls)?

Recommendation from Subcommittee:

1. Yes. The Family and Community Engagement Committee is working directly with the MPS IT Department to enable this feature for future meetings.
2. It allows for other "interpreters" to translate in live time as the host is presenting.

Will we require ALL parents to respond to reopening surveys?

Recommendation from Subcommittee:

1. There is no requirement, however, we do highly encourage participation since parent input helps to guide decision making.

Who are the designees for Family and Community Engagement at each MSA?

Recommendation from Subcommittee:

1. Lead: Office Manager
2. Co-lead: Parent and Community Engagement Coordinator/Dean of Culture if applicable
3. Alternates: School administrator/s

Third-party visitor policy recommendations

Recommendation from Subcommittee:

1. Create an essential third-party vendors list for approved access. Those without approved access will not be allowed entry.
2. By appointment only and or a pre-approved time slot

Distancing: Non-classroom Spaces

Recommendation from Subcommittee:

1. An MPS wide policy limiting parent access to school grounds including classrooms.
2. An outdoor tent is set up for admin access to parents.
3. An appointment system for all visitors, including parents, no walk-ins.
4. Prohibited items brought in to school during operating hours, including lunch and homework.
5. A policy in regard to donations and wish list items.
 - School to have labeled boxes/tables for all donation items.
6. Postpone shadowing services.
7. Mandatory meetings such as IEP, ELAC, 504, SST, to be held virtually.

Distancing: Arrival and Departure

Recommendation from Subcommittee:

1. Staggered arrival and pick up times (Use MSA-Santa Ana schedule as reference)
2. Drop-off and Pick-up: From car door to classroom door policy.
3. Parents not to exit cars during pick up and drop off. Including siblings
4. No restroom usage during drop-off and pick-up.
5. Designated waiting areas with physical distancing for walk-in parents.

NEXT STEPS

MSA and Home Office ACTION STEPS, along with staffing and financial implications, and timelines have been established by the Family & Community Engagement Subcommittee. The Family and Community Engagement Subcommittee recommends the following next steps for all Magnolia Science Academies.

The Family and Community Engagement Subcommittee has put forward the following areas of consideration to focus on:

Engage families in decision-making

- Stakeholder Surveys - Encourage participation
- School website Updates (COVID-19 Info & Resource Center, News and Announcements, and Alerts)
- Developing incentives to keep the community engaged and to improve participation.

Multi-faceted communication methods through different platforms

- Using virtual platforms as a way of communicating via ParentSquare, having Virtual Coffee with the Principal, Virtual Town Hall, and Virtual Parent Task Force Meetings...etc.

- Using a social media toolkit to reach as many of our stakeholders
- Making sure that our stakeholders are given up-to-date information regarding the re-opening of the schools and any other pertinent information regarding COVID-19.

Multi-dimensional messaging

- Allows for all stakeholders to be informed and engaged.
- Know face with name/title.
- Using all communication tools and follow up if there is anybody left behind during any Virtual meetings (a. Parent square with confirmation b.fliers/emails c.emails and websites [Alerts, News, and announcements])
- Grade Level Meetings
- Using nonverbal message tools in the school environment to instruct/ provide directions to staff, students, and parents with posters, infographics, banners signages for messaging purposes., Computer teachers can create posters regarding Health and Safety. Every grade level can support. Art teachers can create creative & dynamic posters on social-emotional supports.

Establish and inform families on protocols and procedures

- The home office to review MPS policies such as Volunteer and Shadowing policy, and MPS Student/Parent handbook (discipline policies, aligning with SEL, and procedures for being safe)
- Designate a school site member to post website and ParentSquare
- Maintain a welcoming environment for all families.

Incorporate flexibility

- Schools should check compliance plans regarding before/after school child care programs and planning morning drop off and pick up based on the feedback from surveys and town hall meetings.
- Schools should provide their own:
 - Incorporate a flexibility plan with the support/approval of the Home Office.
 - Notify all families immediately of any positive COVID-19 cases with the approval of the Home Office HOST Team.
 - Maintain communication systems to allow staff and families to self-report symptoms and receive prompt notifications of exposures and closures.
 - Each campus should provide its own flexibility plan depending upon their needs and campus availability.
 - HOST Team to support admin at the school site and/ or to support for clear communication with all Stakeholders informing of the situation

Budget Implications

- Check all budget impacts for any additional cost with Home office and Finance team
- Research local grants and donations and forward to the Development & Communications Department

Support families when children are ill/at home

- Schools to support families.
- Developing training for parents to help become more aware of Social Emotional Learning (SEL), mental health, and distance learning (tips and tricks).

Creating Effective Communication Systems

- Share the reopening plan with parents and staff on ParentSquare.
- Share the one-pager with parents regarding highlights from the meetings.

- The Family & Community Engagement Subcommittee will share A GUIDE TO ADDRESS THE CHALLENGES OF COVID-19 infographic to help families as we near the Fall 2020 reopening.
- By using all communication tools to provide updates such as on-site meetings, ParentSquare with confirmation, fliers, emails, website (alerts, news, and announcements), and follow up if there is anybody left behind.
- Create a physical update outdoor bulletin during drop off and pick up.
- Add all COVID-19 as the leading agenda item on all standing meetings such as Coffee with Admin, SSC, ELAC, PTF.
- It is recommended that the aforementioned protocols be added to MPS Monthly checklist for all MSA Principals.

RESOURCES

Los Angeles County:

- [211 LA County](#) - Resources available to all county residents to assist with health and human services. They can provide information and referrals to food distribution sites/programs, housing, health care and more.
- [Child Care Alliance of Los Angeles](#) - Find child care or get additional information by zip code. The resource and referral agencies in the network have free, personalized referrals to licensed child care providers.
- [Communicate with Families During COVID-19](#) - Researchers outline four strategies to help leadership execute basics to quickly and effectively keep school communities well-informed about the COVID-19 outbreak, resulting policies and current guidelines, as well as equip families with the right information at the right time.
- [My Health LA](#) - No-cost health care program for people who live in Los Angeles County. MHLA is free to individuals and families who do not have and cannot get health insurance.

Orange County:

- [Western Youth Services](#) - Advancing awareness, cultivating success, and strengthening communities through integrated mental health services for children, youth, and families.
- [Help Me Grow](#) - Help Me Grow connects children and their families to developmental services to enhance the development, behavior, and learning of children birth through eight years. Affiliated with the University of California, Irvine.
- [Choc Children's](#) - Committed to providing the highest quality medical care to children. Affiliated with the University of California, Irvine.

San Diego County:

- [First 5 San Diego](#) - First 5 San Diego's Healthy Development Services (HDS) provides no-cost developmental checkups for children from birth through 5 years of age and connects children and families to needed services. First 5 San Diego works with some of the best community agencies in San Diego County to ensure parents and other caregivers have the help they need to promote their children's developmental and behavioral health.
- [211 San Diego](#) - What is 211? As a local non-profit operating 24 hours a day, 365 days each year, 211 San Diego is the region's trusted source for access to the community, health, social, and disaster services. By simply dialing 211 the call is free, confidential, and available in more than 200 languages. 211 provides access to 6,000+ services, resources, and programs through our online database.
- [SDCOE Resources for Students & Parent](#)



MPS Hybrid Reopening Plans



March 11, 2021

MPS BOARD
MEETING

Introduction

- In compliance with health and safety orders, community expectations and corresponding law and regulations, **MPS has been preparing to open its campuses for in-person instruction.**
- MPS has **Reopening Task Forces** that has been meeting since May 2020 with a goal of reopening our school campuses for the continuity of high quality of education with the safety and protection of all in mind with the guiding principles of equity and access for all, inclusive process with voices and choices and commitment to MPS values of innovation, connections and excellence.
- The Task force has been working on the **Reopening Plans** based on the frameworks and guidelines from multiple agencies including **CDPH, LACOE, OCDE, SDCOE** and related county health departments, keeping up with research based on best practices, national and international experiences and engaging all stakeholders in the process by collecting the relevant information and data for an informed and sound decision.

Background

On March 5, 2021, Governor Newsom signed **AB 86 providing \$2 billion for safe in-person instruction support** and \$4.6 billion for expanded academic, mental health and social-emotional support. It provides \$2 billion as an incentive for schools that have not already done so to offer in-person instruction beginning April 1, starting with the earliest grades. The legislation also allocates \$4.6 billion for all school districts regardless of whether they meet the timetable in the **“Safe Schools for All”** plan. To get the extra funding, districts and charters are expected to provide **in-person instruction to a range of students with special needs — such as those in special education or others in “prioritized groups,”** such as English learners, homeless students or those in foster care, and even **“disengaged”** students.

Approved by Governor on June 29, 2020, **Senate Bill 98** also regulates **Distance Learning** and requires compliance with daily live instructions and instructional minutes, connectivity and devices, grade level content, academic supports, special Education, ELD instruction/assessment, daily live interaction with certificated employees and peers. **If daily live interaction is not feasible as part of regular instruction, the governing board or body of the local education agency shall develop, with parent and stakeholder input, an alternative plan for frequent live interaction that provides a comparable level of service and school connectedness.**

Based on the guidance and orders, on July 23, 2020, MPS Board approved schools to start **virtually with full Distance Learning models** for MSAs 1-8 on August 18, 2020, for MSA-Santa Ana on August 10, 2020 and for MSA-San Diego on August 31, 2020. The schools have been providing **Distance Learning** per the January 14, 2021 updated **CDPH’s COVID-19 and Reopening In-Person Learning Framework for K-12 Schools in California.**

Steps for reopening in-person



- 1- Schools decide on the instructional model - done
- 2- Notice to county and authorizers for re-opening
- 3- Conduct parent/student town hall meetings - ongoing
- 4- Have parents commit with a model for the remainder of the school year by March 19.
- 5- Determine student counts.
- 6- Determine and address staffing needs.
- 7- Update class rosters and student schedules if needed
- 8- Teacher planning times. Modify live session schedules
- 9- Order instructional materials and supplies. Get lists from staff.
- 10- Dry run/planning on school sites
- 11- Final check of plans and issues

Remaining Items for Safe School Return

- Submit COVID Safety Plans for all schools and LACDPH Reopening Protocol for K-12 schools (Appendix T1).
- Continue to partner with our authorizers, county health departments, and other state agencies to ensure that our staff get vaccinated if they choose to do so.
- Survey our parents to reassess interest for student return to on campus learning (commitment form).
- Based on survey results, collaboratively finalize elementary, middle and high school Hybrid and Distance Learning schedules.
- MSA 1-8 Santa Ana and San Diego Town Hall meetings with families to review Hybrid schedules and safety protocols for each school site, amongst other items.
- Continue to analyze and operationalize all elements of AB 86
- Reopen all of our schools for in-person Hybrid learning on April 12, 2021.

Preferred Hybrid Reopening Model

Live Instruction for Students - (2 days in person, 2 days via Zoom)

Group	Monday & Tuesday	Wednesday	Thursday & Friday
Cohort A	In-Person	Asynch/Independent Learning	Online
Cohort B	Online	Asynch/Independent Learning	In-Person
Distance Learning	Online	Asynch/Independent Learning	Online

- Cohort A coming to school on Monday and Tuesday. **Cohort B joining online through Zoom**
- Cohort B coming to school on Thursday and Friday. **Cohort A joining online through Zoom**

Wednesdays - Asynchronous / Independent Learning for all, except for live SEL/ Advisory/SSR lessons (also may be small group sessions in person)

Full Distance Learning students joining classes online through Zoom

Hybrid (in-person) or Distance Learning ?

- Once a choice is made, it will remain unchanged until the end of this school year. Students and families will not have options to switch from distance learning to in-person or vice versa unless there are extenuating circumstances.
- Students who chose hybrid model, will take all classes in hybrid format.
- Schools will assign an in-person cohort for those who choose the hybrid format.
- Everyone else will continue receiving Full Distance Learning if a choice is not made by March 19, 2020.

Sample Schedule

MSA-2 Distance Learning Schedule for Students

Total Daily Instructional Time = 240 mins	Monday	Tuesday	Wednesday	Thursday	Friday
8:00 am - 9:20 am (80 minutes)	Period 1 Cohort 1 in person Cohort 2 via Zoom Cohort 3 DL via Zoom	Period 4 Cohort 1 in person Cohort 2 via Zoom Cohort 3 DL via Zoom	Sync Homeroom All Cohorts Via Zoom 8:00 am - 10:00 am	Period 1 Cohort 2 in person Cohort 1 via Zoom Cohort 3 DL via Zoom	Period 4 Cohort 2 in person Cohort 1 via Zoom Cohort 3 DL via Zoom
9:20 am- 9:25 am	BREAK			BREAK	
9:25am- 10:45am (80 minutes)	Period 2 Cohort 1 in person Cohort 2 via Zoom Cohort 3 DL via Zoom	Period 5 Cohort 1 in person Cohort 2 via Zoom Cohort 3 DL via Zoom	Asynchronous work time 10:00 am - 10:45 am	Period 2 Cohort 2 in person Cohort 1 via Zoom Cohort 3 DL via Zoom	Period 5 Cohort 2 in person Cohort 1 via Zoom Cohort 3 DL via Zoom
10:45 am - 10:50 am	BREAK				
10:50 am- 12:10 pm (80 minutes)	Period 3 Cohort 1 in person Cohort 2 via Zoom Cohort 3 DL via Zoom	Period 6 Cohort 1 in person Cohort 2 via Zoom Cohort 3 DL via Zoom	Asynchronous work time	Period 3 Cohort 2 in person Cohort 1 via Zoom Cohort 3 DL via Zoom	Period 6 Cohort 2 in person Cohort 1 via Zoom Cohort 3 DL via Zoom
12:10 pm	In person Dismissal			In person Dismissal	
12:10 pm - 1:00 pm	LUNCH				
1:00 pm- 1:30 pm	Asynchronous Homeroom		Asynchronous work time	Asynchronous Homeroom	
1:30pm - 2:30pm	Office Hours / Clubs	Test Prep / Targeted Group Intervention		Test Prep / Targeted Group Intervention	Office Hours / Clubs
2:30pm - 3:30pm	Tutoring	Tutoring		Tutoring	Tutoring

HEALTH AND SAFETY PREPAREDNESS

- [MPS COVID-19 Health & Safety Policy](#)
- [Injury Illness Prevention Plan \(IIPP\)](#)
[COVID-19 Addendum /](#)
[CALOSHA Emergency Standards](#)



Protocols and Procedures: COVID-19 Compliance Team



COVID 19 Compliance Team at the Home Office:

- Keeps up to date with the changes in COVID-19 requirements, trends, and updates.
- Provides weekly trainings and updates to the school sites' COVID-19 Compliance team members.
- Consults with the School site Compliance teams and local health authorities regarding cases on campus.
- Consults with legal and health departments to provide clarity when needed
- Coordinate 3rd party vendors with school site teams.



The COVID-19 Compliance Task Force at each school are responsible for ensuring that the school adheres to COVID-19 requirements.

- The COVID-19 Compliance Task Force for each school are led by the **principal**. The principal are the designated liaison with the local County Department of Public Health when needed. The principal may also designate staff to act as the COVID-19 Compliance Officer, as appropriate.
- The rest of the Compliance team is composed of a diverse group of key staff members. The Task Force receives specialized training to assist in their duties and ongoing support from the Home office Compliance team
- The COVID-19 Compliance Task Force is responsible for engaging with students, parents, faculty, and staff to ensure compliance and answer questions or concerns about health and safety requirements regarding COVID-19. In addition, the team communicates up-to-date policies and procedures to all families.

MPS Health & Safety Policy & IIPP Highlights

Wellness Check



SOCIAL DISTANCING



- Wellness checks and temperature screenings
- Physical distancing in Classrooms and campus
- Ventilation upgrades
- PPE supply and compliance
- Identification of COVID-19 Hazards and COVID-19 inspections
- COVID-19 testing for students and staff
- Vaccines for staff

Student Check-in



Parent/Visitor Check-in



Video demo of screening process:



These procedures will be applicable for parents and students
once school open for students and parents.

Classroom Set-up



Student Barriers

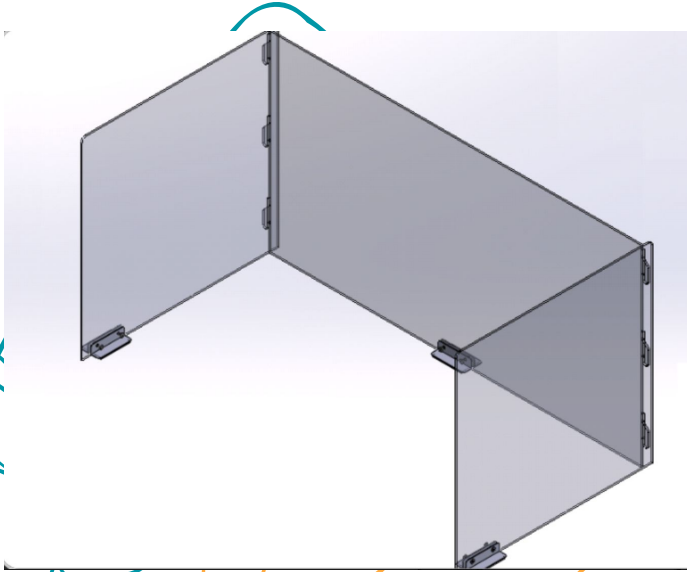

6 ft distancing cones



6 ft distancing markers

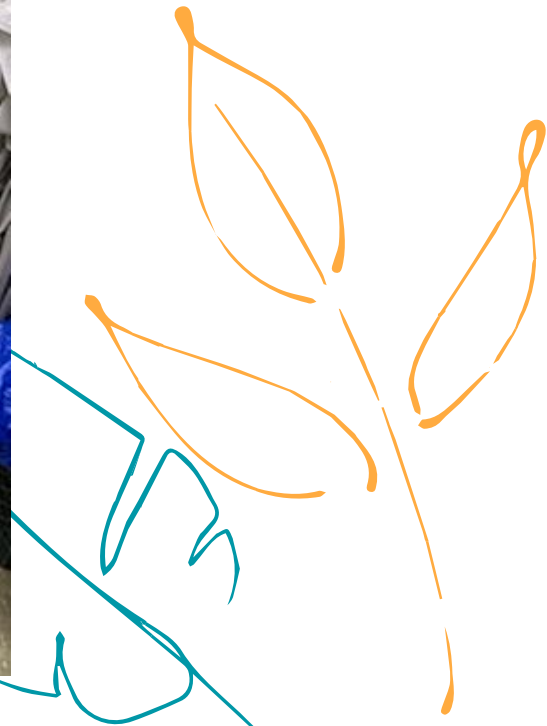

Next Steps



- 1- Schools decide on the instructional model - done
- 2- Notice to county and authorizers for re-opening
- 3- Conduct parent/student town hall meetings - ongoing
- 4- Have parents commit with a model for the remainder of the school year by March 19.
- 5- Determine student counts.
- 6- Determine and address staffing needs.
- 7- Update class rosters and student schedules if needed
- 8- Teacher planning times. Modify live session schedules
- 9- Order instructional materials and supplies. Get lists from staff.
- 10- Dry run/planning on school sites
- 11- Final check of plans and issues



Questions And Comments

