



Board Agenda Item #	II F - Consent Item
Date:	March 21 <sup>st</sup> , 2019
To:	Magnolia Board of Directors
From:	Alfredo Rubalcava, CEO & Superintendent
Staff Lead:	Rasul Monoshev, Director of Technology
RE:	<p>Contract Approval for Staples, Digital Synergy – Viewsonic interactive display for wall mount, on mobile cart options and the labor for installation.</p> <p>Recommendations:</p> <p>One-time fee for Magnolia Science Academy-1(MSA-1) and Magnolia Science Academy-8(MSA-8) for the screen and labor for below options per one unit basis:</p> <ul style="list-style-type: none"> <li>• <b>If 75” IFP7550 and wall mount–Staples, \$2,816.40</b></li> <li>• <b>If 75” IFP7550 on mobile cart– Staples, \$3,047.06</b></li> <li>• <b>If 65” IFP6560 and wall mount– Staples, \$2,710.17</b></li> <li>• <b>If 65” IFP6560 on mobile cart– Staples, \$2,940.83</b></li> <li>• <b>If 65” IFP6550 and wall mount– Digital Synergy, \$1,875.00</b></li> <li>• <b>If 65” IFP6550 on mobile cart– Staples, \$1,984.97</b></li> <li>• <b>Labor for installation for wall or cart options - Digital Synergy, \$165 per screen</b></li> </ul>

Proposed Board Recommendation

I move that the board awards the winning bid for the published RFP and adopt the purchase of MPS Interactive Display for Magnolia Public Schools as set forth above. Should there be a similar need for any other Magnolia Public Schools (MPS), the approved vendor, the need, and the price will be used between the dates March 22<sup>nd</sup>, 2019 – June 30<sup>th</sup>, 2020.

Background

Since the high quality ultra-short throw projectors are almost as expensive as the touchscreen interactive displays, the schools started piloting the ViewSonic devices in 2018. (The actual research we did was back in year 2016 for MSA Santa Ana construction for the Promethean displays, but due to budget constraints later on, we never bought the items for the school even after the board approval – the



approximate cost per device around that time was \$4,500). With touchscreen displays, the teachers can show the videos and lesson contents in high quality. Also, we've seen that in some Magnolia schools, even the whiteboards are not used anymore because the displays answer all the needs for writing on readable surface.

The MPS IT Department originally opened the RFP process for which the due date was February 6th, 2019. But after seeing the discrepancies in received bids and deciding to add the warranty and manufacturer authorization for the reseller, we canceled the original RFP, amended it, and posted as attached. The amended RFP's due date was extended until March 6<sup>th</sup>, 2019. The RFP evaluation committee consisted of MPS IT Director, Mr. Monoshev, MSA-8 IT Manager, Julian Lopez, and MSA-1 IT Manager, Albert Nguyen. The committee evaluated the received bids on March 7<sup>th</sup>, 2019 and met again for confirmation and finalization on March 11<sup>th</sup>, 2019. The team recommends awarding of the bid to Staples and Digital Synergy for the interactive display wall mount, mobile cart options and for the labor for installation.

<b>Factor</b>	<b>Weight</b>
Cost of products and services (required, highest weight)	40%
Functionality/completeness/specifications of proposed solution	30%
Vendor: qualifications, credentials, certifications, experience, references	20%
Contract terms and conditions	10%
<b>Total</b>	<b>100.00%</b>

Budget Implications

The purchase of MPS Interactive displays is budgeted as follows:

- MSA-8 has budgeted \$22,000 for the need for one time cost for FY 2018-19. (We will request for five displays instead of six as originally planned – the school wanted 65” initially, but after seeing such lower prices, now want to buy 75” instead)
- MSA-1 has a budget of \$220,000 for low voltage. And the \$59,628 amount is covered within this Construction budget line item.

Attachments:

- Evaluation matrices
- RFP
- Proposals from vendors

Name of Staff Originator: Rasul Monoshev

<b>MPS Interactive Display Bids Evaluation</b>							
<b>IFP7550 75" Viewsonic Screens and mounts</b>							
	<b>California Western Visuals</b>	<b>ELB</b>	<b>STS Education</b>	<b>Digital Synergy</b>	<b>Troxxel</b>	<b>Alpha Solutions</b>	<b>Staples</b>
Price per unit screen	\$2,740.54	\$4,830.00	\$3,099.00	\$2,800.00	\$2,239.00	\$3,100.00	\$2,655.98
Price per the mount	\$140.00	\$0.00	\$599.00	\$0.00	\$118.00	\$430.00	\$160.42
Warranty for 4th and 5th year (extended)	\$1.00	\$0.00	\$0.00	\$0.00	\$0.00	\$0.00	\$0.00
Total price for the screens mounts, and cables(40%)	<b>\$2,881.54</b>	<b>\$4,830.00</b>	<b>\$3,698.00</b>	<b>\$2,800.00</b>	<b>\$2,357.00</b>	<b>\$3,530.00</b>	<b>\$2,816.40</b>
Functionality/specification of items(30%)	IFP7550	PROWISE	iSeries	IFP7550	ProColo752U	IFP7550	IFP7550
Vendor Qualifications(20%)	Well Qualified	Well Qualified	Well Qualified	Well Qualified	Well Qualified	Well Qualified	Well Qualified
Terms and Conditions(10%)	Good	Good	Good	Good	Good	Good	Good
<b>Evaluation</b>							
Pricing including tax (Max 40 points)	34	20	27	35	40	26	36
Functionality/specification of items (Max 30 points)	30	15	15	30	10	30	31
Vendor Qualifications (Max 20 points)	20	20	20	20	20	20	20
Terms and Conditions (Max 10 points)	10	10	10	10	10	10	10
	<b>94</b>	<b>65</b>	<b>72</b>	<b>95</b>	<b>80</b>	<b>86</b>	<b>97</b>
The Winning bid is Staples							

<b>MPS Interactive Display Bids Evaluation</b>							
<b>IFP7550 75" Viewsonic Screens and mounts</b>							
	<b>California Western Visuals</b>	<b>ELB</b>	<b>STS Education</b>	<b>Digital Synergy</b>	<b>Troxxel</b>	<b>Allpha Solutions</b>	<b>Staples</b>
Price per unit screen	\$2,740.54	\$7,116.00	\$3,099.00	\$3,150.00	\$2,239.00	\$3,150.00	\$2,655.98
Price per the cart	\$382.00	\$0.00	\$429.00	\$0.00	\$258.00	\$0.00	\$391.08
Warranty for 4th and 5th year (extended)	\$1.00	\$0.00	\$0.00	\$0.00	\$0.00	\$0.00	\$0.00
Total price for the screens mounts, and cables(40%)	<b>\$3,123.54</b>	<b>\$7,116.00</b>	<b>\$3,528.00</b>	<b>\$3,150.00</b>	<b>\$2,497.00</b>	<b>\$3,150.00</b>	<b>\$3,047.06</b>
Functionality/specification of items(30%)	IFP7550	PROWISE	iSeries	IFP7550	ProColo752U	IFP7550	IFP7550
Vendor Qualifications(20%)	Well Qualified	Well Qualified	Well Qualified	Well Qualified	Well Qualified	Well Qualified	Well Qualified
Terms and Conditions(10%)	Good	Good	Good	Good	Good	Good	Good
<b>Evaluation</b>							
Pricing including tax (Max 40 points)	35	20	27	25	40	26	36
Functionality/specification of items (Max 30 points)	30	15	15	30	10	30	30
Vendor Qualifications (Max 20 points)	20	20	20	20	20	20	20
Terms and Conditions (Max 10 points)	10	10	10	10	10	10	10
	<b>95</b>	<b>65</b>	<b>72</b>	<b>85</b>	<b>80</b>	<b>86</b>	<b>96</b>
The Winning bid is Staples							

<b>MPS Interactive Display Bids Evaluation</b>			
<b>IFP6560 65" Viewsonic Screens and mounts</b>			
	<b>California Western Visuals</b>	<b>Digital Synergy</b>	<b>Staples</b>
Price per unit screen	\$2,632.22	\$2,720.00	\$2,549.75
Price per the mount	\$410.00	\$400.00	\$160.42
Warranty for 4th and 5th year (extended)	\$1.00	\$0.00	\$0.00
Total price for the screens mounts, and cables(40%)	<b>\$3,043.22</b>	<b>\$3,120.00</b>	<b>\$2,710.17</b>
Functionality/specification of items(30%)	ifp6560 model	ifp6560 model	ifp6560 model
Vendor Qualifications(20%)	Well Qualified	Well Qualified	Well Qualified
Terms and Conditions(10%)	Good	Good	Good
<b>Evaluation</b>			
Pricing including tax (Max 40 points)	35	30	40
Functionality/specification of items (Max 30 points)	30	30	30
Vendor Qualifications (Max 20 points)	20	20	20
Terms and Conditions (Max 10 points)	10	10	10
	<b>95</b>	<b>90</b>	<b>100</b>
The Winning bid is Staples			

<b>MPS Interactive Display Bids Evaluation</b>			
<b>IFP6560 65" Viewsonic Screens and mounts</b>			
	<b>California Western Visuals</b>	<b>Digital Synergy</b>	<b>Staples</b>
Price per unit screen	\$2,632.22	\$2,720.00	\$2,549.75
Price per the cart	\$382.00	\$400.00	\$391.08
Warranty for 4th and 5th year (extended)	\$1.00	\$0.00	\$0.00
Total price for the screens mounts, and cables(40%)	<b>\$3,015.22</b>	<b>\$3,120.00</b>	<b>\$2,940.83</b>
Functionality/specification of items(30%)	IFP6560	IFP6560	IFP6560
Vendor Qualifications(20%)	Well Qualified	Well Qualified	Well Qualified
Terms and Conditions(10%)	Good	Good	Good
<b>Evaluation</b>			
Pricing including tax (Max 40 points)	35	34	40
Functionality/specification of items (Max 30 points)	30	30	30
Vendor Qualifications (Max 20 points)	20	20	20
Terms and Conditions (Max 10 points)	10	10	10
	<b>95</b>	<b>94</b>	<b>100</b>
The Winning bid is Staples			

MPS Interactive Display Bids Evaluation							
<b>IFP6550 65" Viewsonic Screens and mounts</b>							
	<b>California Western Visuals</b>	<b>ELB</b>	<b>STS Education</b>	<b>Digital Synergy</b>	<b>Troxxel</b>	<b>Alpha Solutions</b>	<b>Staples</b>
Price per unit screen	\$1,864.16	\$4,160.00	\$2,099.00	\$1,875.00	\$1,725.00	\$2,028.00	\$1,824.55
Price per the mount	\$410.00	\$0.00	\$429.00	\$0.00	\$105.00	\$430.00	\$160.42
Warranty for 4th and 5th year (extended)	\$1.00	\$0.00	\$0.00	\$0.00	\$0.00	\$0.00	\$0.00
Total price for the screens mounts, and cables(40%)	<b>\$2,275.16</b>	<b>\$4,160.00</b>	<b>\$2,528.00</b>	<b>\$1,875.00</b>	<b>\$1,830.00</b>	<b>\$2,458.00</b>	<b>\$1,984.97</b>
Functionality/specification of items(30%)	IFP6550	PROWISE	iSeries	IFP6550	ProColo652U	IFP6550	IFP6550
Vendor Qualifications(20%)	Well Qualified	Well Qualified	Well Qualified	Well Qualified	Well Qualified	Well Qualified	Well Qualified
Terms and Conditions(10%)	Good	Good	Good	Good	Good	Good	Good
<b>Evaluation</b>							
Pricing including tax (Max 40 points)	37	40	40	39	40	33	38
Functionality/specification of items (Max 30 points)	30	20	12	30	15	30	30
Vendor Qualifications (Max 20 points)	20	20	20	20	20	20	20
Terms and Conditions (Max 10 points)	10	10	10	10	10	10	10
	<b>97</b>	<b>90</b>	<b>82</b>	<b>99</b>	<b>85</b>	<b>93</b>	<b>98</b>
The Winning bid is Digital Synergy							

<b>MPS Interactive Display Bids Evaluation</b>							
<b>IFP6550 65" Viewsonic Screens and mounts</b>							
	<b>California Western Visuals</b>	<b>ELB</b>	<b>STS Education</b>	<b>Digital Synergy</b>	<b>Troxxel</b>	<b>Allpha Solutions</b>	<b>Staples</b>
Price per unit screen	\$1,864.16	\$6,021.00	\$2,099.00	\$2,189.00	\$1,725.00	\$2,028.00	\$1,824.55
Price per the cart	\$382.00	\$0.00	\$429.00	\$0.00	\$384.00	\$388.00	\$160.42
Warranty for 4th and 5th year (extended)	\$1.00	\$0.00	\$0.00	\$0.00	\$0.00	\$0.00	\$0.00
Total price for the screens mounts, and cables(40%)	<b>\$2,247.16</b>	<b>\$6,021.00</b>	<b>\$2,528.00</b>	<b>\$2,189.00</b>	<b>\$2,109.00</b>	<b>\$2,416.00</b>	<b>\$1,984.97</b>
Functionality/specification of items(30%)	IFP6550	PROWISE	iSeries	IFP6550	ProColo652U	IFP6550	IFP6550
Vendor Qualifications(20%)	Well Qualified	Well Qualified	Well Qualified	Well Qualified	Well Qualified	Well Qualified	Well Qualified
Terms and Conditions(10%)	Good	Good	Good	Good	Good	Good	Good
<b>Evaluation</b>							
Pricing including tax (Max 40 points)	36	25	32	30	40	34	38
Functionality/specification of items (Max 30 points)	30	20	20	30	20	30	30
Vendor Qualifications (Max 20 points)	20	20	20	20	20	20	20
Terms and Conditions (Max 10 points)	10	10	10	10	10	10	10
	<b>96</b>	<b>75</b>	<b>82</b>	<b>90</b>	<b>90</b>	<b>94</b>	<b>98</b>
The Winning bid is Staples							







## REQUEST FOR PROPOSALS

### MAGNOLIA SCIENCE ACADEMY-1 and MAGNOLIA SCIENCE ACADEMY-8 INTERACTIVE DISPLAY NEED

(Due Date – **March 6<sup>th</sup>, 2019**)

**with AMENDMENTS on last page and highlighted red in the document**

#### PURPOSE

Magnolia Public Schools (“**MPS**”) is soliciting proposals for interactive displays at its Magnolia Science Academy – 1 (“**MSA-1**”) and Magnolia Science Academy – 8 (“**MSA-8**”) schools. MPS is presently constructing a new classroom building at 18220 Sherman Way for the benefit of MSA-1. The interactive displays will serve as the main audio-visual service in the classroom replacing traditional classroom projectors. The mounting service labor for the system should be also included in the SOW. The submitted bid such include the below options in separate quotes:

Option 1(separate quote): 75” display and wall mount and mounting service labor.

Option 2(separate quote): 75” display and a stand on a wheel.

Option 3(separate quote): 65” display and wall mount and mounting service labor.

Option 2(separate quote): 65” display and a stand on a wheel.

*Should there be a need for any other MPS schools listed below between dates July 1<sup>st</sup>, 2018 – June 30<sup>th</sup>, 2020, the approved vendor, the appliance/service model, and the price will be used for the purchase:*

<b>MPS School</b>	<b>Address</b>
MSA-1	18238 Sherman Way, Reseda, CA 91335
MSA-2	17125 Victory Blvd., Van Nuys, CA 91406
MSA-3	1254 East Helmick Street, Carson, CA 90746



<b>MPS School</b>	<b>Address</b>
MSA-4	11330 West Graham Place, Los Angeles, CA 90064
MSA-5	18230 Kittridge St., Reseda, CA 91335
MSA-6	3754 Dunn Dr., Los Angeles, CA 90034
MSA-7	18355 Roscoe Boulevard, Northridge, CA 91325
MSA-8	6411 Orchard Ave., Bell, CA 90201
MSA-Santa Ana	2840 W. 1st Street, Santa Ana, CA 92703
MSA-San Diego	6525 Estrella Ave., San Diego, CA 92120

## **GENERAL TERMS AND CONDITIONS FOR RFP PROPOSAL GUIDELINES**

1. Each item request and guideline in this RFP must be properly addressed in the proposal.
2. All equipment in the submitted proposal must conform to specifications provided in this RFP.
3. The Vendor must provide terms of warranty on all products.
4. The Vendor shall provide a clear itemized breakdown of equipment and service costs.
5. The Vendor must provide an estimated timeline for product delivery and installation.
6. Proposal must be valid for 60 days.

**All questions regarding this RFP should be addressed in writing to Rasul Monoshev, MPS IT Director, at [rmonoshev@magnoliapublicschools.org](mailto:rmonoshev@magnoliapublicschools.org).**

## **PROPOSAL SUBMISSION**

Proposals are to be submitted for receipt no later than **5:00 PM PST, Wednesday, 03/06/2019** and may be delivered as follows:

**Email to:**



[it@magnoliapublicschools.org](mailto:it@magnoliapublicschools.org), [jblopez@magnoliapublicschools.org](mailto:jblopez@magnoliapublicschools.org),  
[anguyen@magnoliapublicschools.org](mailto:anguyen@magnoliapublicschools.org)

[Subject: MSA-1 & MSA-8 interactive displays 2019]

## **ACCEPTANCE/REJECTION OF PROPOSAL SUBMISSIONS**

MPS reserves the right to accept or reject any and all proposals or any portion of any and all proposals in its discretion. While price is an important consideration, it will not be the sole determining factor in the selection of a Vendor. Payments will not be made nor orders submitted until after the MPS Board of Directors has accepted a proposal and awarded it as the winning proposal submission. A contract will be entered into between MPS and the Vendor after the aforementioned approvals.

## **PAYMENT**

Payment shall be made no later than 60 days after invoice date. The payment will not be issued until after both the Vendor and MPS agree that the project is complete and meets all requirements.

## **RFP Revisions**

MPS reserves the right to modify or issue amendments to this RFP at any time. MPS also reserves the right to cancel or reissue this RFP at any time. Notices will be posted to <http://magnoliapublicschools.org>. It is the sole responsibility of interested vendors to monitor the URL for posting of such information.

## **RFP EVALUATION**

All qualified, responsive proposals will be evaluated using the following factors and weights.



Factor	Weight
Cost of products and services (required, highest weight)	40%
Functionality/completeness/specifications of proposed solution	30%
Vendor qualifications, credentials, certifications, experience, and references	20%
Contract terms and conditions	10%
<b>Total</b>	<b>100.00%</b>

## RFP Evaluation Committee

The RFP Evaluation committee members are as follows:

- Rasul Monoshev, IT Director
- Julian Lopez, MSA-1 IT Manager
- Albert Nguyen, MSA-8 IT Manager

## RFP Evaluation and Award Timeline

03.06.2019: RFP is due at 5pm.

03.07.2019: The RFP Evaluation committee members will meet and evaluate the received bids

03.12.2019: The winning bid recommendation is submitted in documentation

03.21.2019: MPS Board Meeting day – The board might approve/deny/request for more information

## EQUIPMENT & SERVICES SPECIFICATIONS

**Magnolia Science Academy-1 (Please see background section on 1<sup>st</sup> page as we want 4 options on separate quotes for wall mounting option and the stand on the wheels option for mobility - to be able to move the display from one classroom to other)**

**Item 1:**

**Quantity:** 20

**Description: Interactive Display Board:** Viewsonic IFP7550 and IFP6560 or similar options on separate quotes (Description: 20 - 65" on one quote and 20 – 75" quote on separate on a second quote)



**Item 2:**

**Quantity:** 20

**Description:** Diversitrack Hover Mount or similar for Item 1 (NOTE compatible mount is required for 75" display), Interactive Displays and mounting service for those.

**Magnolia Science Academy-8 (Please see background section on 1<sup>st</sup> page as we want 4 options on separate quotes for wall mounting option and the stand on the wheels option for mobility - to be able to move the display from one classroom to other)**

**Item 1:**

**Quantity:** 6

**Description: Interactive Display Board:** Viewsonic IFP7550 and IFP6560 or similar options on separate quotes (Description: 20 - 65" on one quote and 20 – 75" quote on second quote)

**Item 2:**

**Quantity:** 6

**Description:** Diversitrack Hover Mount or similar for Item 1 (NOTE compatible mount is required for 75" display), Interactive Displays and mounting service for those.

**Delivery/Shipping**

**NOTE:** No dock at this location.

**Bill to Address:**

Magnolia Public Schools, Magnolia Public Schools, 250 East First St, STE1500, Los Angeles, CA 90012

**Ship to Address: Magnolia Science Academy-1 and 8 respectively**



## **AMENDMENTS:**

- 1. Please provide with any supporting documentation that the vendor is an authorized dealer for the Viewsonic devices**
- 2. Include the Interactive Display Extended On-Site Repair Warranty for 4th and 5th Year INCLUDED IN BOARD PRICE to your quote**
- 3. The Hoverboard mount in original bid only supports 65' screen, please bid with the recommended/appropriate mount models for the 75" screen**
- 4. Please include CA Tax calculation in your bid**
- 5. Please separate the labor in separate quote (it is to help our schools later on if they already have the devices and would like to only get labor for installation)**



## Limited Warranty

### ViewSonic® Limited Warranty

(Current Production Models. U.S.A. and Canada Only)

#### What the warranty covers:

ViewSonic warrants its products to be free from defects in material and workmanship during the warranty period. If a product proves to be defective in material or workmanship during the warranty period, ViewSonic will, at its sole option, repair or replace the product with a similar product. Replacement Product or parts may include remanufactured or refurbished parts or components. The replacement unit will be covered by the balance of the time remaining on the customer's original limited warranty. ViewSonic provides no warranty for any third-party software whether included with the product or installed by the customer, installation of any unauthorized hardware parts or components (e.g. Projector Lamps). (Please refer to: "[What the warranty does not cover](#)" section)

ViewSonic "A" Stock Product is defined as:

- Brand new, never been used products freshly received from factory in original packaging
- Packaging must be unopened (other than any cursory un-boxing/re-boxing for quality assurance inspection)

#### How long the warranty is effective:

1. ViewSonic Monitor carry a three (3) year limited warranty for parts, labor and LCD backlight from the purchase date. In order to receive warranty service, proof of purchase of the ViewSonic product is required. To obtain warranty service, please contact ViewSonic Customer Support.
2. ViewSonic Monitors are warranted with our LCD Pixel Performance Guarantee. Through this limited warranty, you are guaranteed high-quality screen performance with no more than the following improperly operating pixels, depending on the native panel resolutions.
  1. Panels with resolution smaller than 3840x2160: Three (3) improperly operating pixels with no more than two (2) bright or two (2) dark pixels.
  2. Panels with resolution 3840x2160 or higher: Eight (8) improperly operating pixels with no more than five (5) bright or five (5) dark pixels.



3. ViewSonic Projectors (unless otherwise specified) are warranted for three (3) years from the date of first consumer purchase for parts and labor and one (1) year limited lamp warranty. Lamp warranty is subject to terms and conditions, verification and approval. Applies to manufacturer's installed lamp only. All accessory lamps purchased separately are warranted for 90 days.
4. ViewSonic Desktop Virtualization products (unless otherwise specified) are warranted for three (3) year for parts and labor.
5. ViewSonic Large Format Display (LFD) products are warranted for three (3) years from the date of first consumer purchase for parts and labor.\*
6. ViewSonic ViewBoard Interactive Flat Panel display (IFP) products are warranted for three (3) years from the date of first consumer purchase for parts and labor.\*
7. ViewSonic Digital Kiosks and Billboards (ePoster) Products are warranted for one (1) year from the date of first consumer purchase for parts and labor.\*

\*All 42" and larger ViewSonic Display Products will receive onsite services in the U.S. and Canada with the following exceptions:

- If the service location of the defective unit is over 40 miles outside a major metropolitan area. The customer will be responsible to ship/transport the covered Product to the designated repair center;
  - If a defective unit is determined by the ViewSonic Technical Support staff to be a panel defect, or ViewSonic's Technician is unable to resolve the problem on-site, a replacement unit will be dispatched from ViewSonic's warehouse to customer's ship-to location (front door deliveries only). It is customer's responsibility to pack and ship/transport the covered Product to the designated repair center.
8. ViewSonic Media Player products (unless otherwise specified) are warranted for one (1) year for parts and labor.
  9. ViewSonic Slot-In PC products are warranted for one (1) year for parts and labor.
  10. ViewSonic accessory products carry limited warranties. See the product page for additional detail by model.
  11. All brand new ViewSonic products carry a thirty (30) day "Dead on Arrival" ("DOA") warranty policy for the first consumer purchaser. A new replacement unit will be provided if the Product is found to be non-operational within thirty (30) days of purchase and freight shall be covered both ways by ViewSonic.

### **Who the warranty protects:**

This warranty is valid only for the first consumer purchaser.

### **What the warranty does not cover:**

- Any product on which the serial number has been defaced, modified or removed.
- Damage, deterioration or malfunction resulting from:
  - a) Accident, misuse, neglect, fire, water, lightning, or other acts of nature, unauthorized product modification, or failure to follow instructions supplied with the product.
  - b) Repair or attempted repair by anyone not authorized by ViewSonic.
  - c) Damage to or loss of any programs, data or removable storage media.
  - d) Software or data loss occurring during repair or replacement.
  - e) Any damage of the product due to shipment.
  - f) Removal or installation of the product.

- g) Causes external to the product, such as electric power fluctuations or failure.
  - h) Use of supplies or parts not meeting ViewSonic's specifications.
  - i) Normal wear and tear.
  - j) Failure of owner to perform periodic product maintenance as stated in User Guide, such as cleaning of user-cleanable projector filters.
  - k) Any other cause which does not relate to a product defect.
  - l) Damage caused by static (non-moving) images displayed for lengthy periods of time (also referred to as image burn-in).
  - m) Software - Any third-party software included with the product or installed by the customer.
  - n) Hardware/Accessories/Parts/Components - Installation of any unauthorized hardware, accessories, consumable parts or components (e.g. Projector Lamps).
  - o) Damage to, or abuse of, the coating on the surface of the display through inappropriate cleaning as described in product User Guide.
  - p) The Product sold and labeled as "AS IS\*", "WITH ALL FAULTS" or similar disclaimer, including replacement of missing parts or accessories from those sales, or purchased through an unauthorized online seller.
- Removal, installation, and set-up service charges, including wall-mounting of product.

#### **How to obtain service:**

- **For general service support information, including download drivers, check RMA status, and FAQs, please visit us at <https://www.viewsonic.com/us/customer-service/>**
- **To obtain warranty service please start here: [www.viewsonic.com/csform](http://www.viewsonic.com/csform)**

#### **Limitation of implied warranties:**

TO THE EXTENT ALLOWED BY LOCAL LAW, THIS PRODUCT IS PROVIDED TO YOU "AS IS" WITHOUT WARRANTIES OR CONDITIONS OF ANY KIND, WHETHER ORAL OR WRITTEN, EXPRESS OR IMPLIED. VIEWSONIC SPECIFICALLY DISCLAIMS ANY IMPLIED WARRANTIES OR CONDITIONS OF MERCHANTABILITY, SATISFACTORY QUALITY, NON-INFRINGEMENT AND FITNESS FOR A PARTICULAR PURPOSE.

#### **Exclusion of damages:**

VIEWSONIC'S LIABILITY IS LIMITED TO THE COST OF REPAIR OR REPLACEMENT OF THE PRODUCT.

VIEWSONIC SHALL NOT BE LIABLE FOR:

- 1) DAMAGE TO OTHER PROPERTY CAUSED BY ANY DEFECTS IN THE PRODUCT,
- 2) DAMAGES BASED UPON INCONVENIENCE, LOST PROFIT, LOST DATA OR DOWNTIME COSTS, LOSS OF USE OF THE PRODUCT, LOSS OF TIME, LOSS OF PROFITS, LOSS OF BUSINESS OPPORTUNITY, LOSS OF GOODWILL, INTERFERENCE WITH BUSINESS RELATIONSHIPS, OR OTHER COMMERCIAL LOSS, EVEN IF ADVISED OF THE POSSIBILITY OF SUCH DAMAGES.
- 3) ANY OTHER DAMAGES, WHETHER DIRECT, SPECIAL, INCIDENTAL, CONSEQUENTIAL OR OTHERWISE.

4) ANY CLAIM AGAINST THE CUSTOMER BY ANY OTHER PARTY.

**Effect of local law:**

This warranty gives you specific legal rights, and you may also have other rights which vary from locality to locality. Some localities do not allow limitations on implied warranties and/or do not allow the exclusion of incidental or consequential damages, so the above limitations and exclusions may not apply to you.

**Sales outside the U.S.A. and Canada:**

For ViewSonic products sold outside the U.S. and Canada, contact your ViewSonic dealer or your region for more warranty information and service for your country. Look up [our locations here](#)









Proposal for:	
Company:	Magnolia Science Academy
Contact:	Rasul Monoshev
Phone:	
Email:	rmonoshev@magnoliapublicschools.org
Valid Date:	3/6/2019
Expires:	5/31/2019

Staples	
Date:	3/5/2019
Staples Contact:	Jonathan Knight
Phone:	() -
Email:	0
Notes:	

Qty.	Part No.	Product Description	UOM	Unit Price	Extended Price
20	IFP6560	Viewsonic 65IN VIEWBOARD 4K ULTRA HD IFP WITH INGLASS	EA	\$ 2,549.70	\$ 50,994.00
20	MI-373	Mount-It! Heavy Duty Mantel TV Mount Pull Down Mounting Bracket	EA	\$ 160.42	\$ 3,208.40
1		Wall Mounting Service	EA	\$ 12,444.44	\$ 12,444.44
	IFP-EW-60-02	ViewSonic Extended Warranty Extended service agreement - parts and labor (for display with 60"-69" diagonal size) - 2 years (4th/5th year) - on-site - for P/N: IFP6550-A, IFP6550-E1, IFP6550-E2, IFP6550-E3, IFP6560 **Included in the price of the Display.**			
		Sales Tax for Reseda, CA of 9.5%			\$ 6,331.45
<b>Total*</b>					\$ 74,583.85

\*Tax, eWaste and freight charges are additional where applicable

Notwithstanding anything to the contrary, Seller reserves the right to adjust pricing proportionate with the impact of tariffs, customs or duties imposed on the Products.

**You can lease this with monthly payments of \$ 2,182.32**

Leasing Options: Staples can help you overcome budget constraints, avoid obsolescence, and reduce upfront cost by leasing your IT assets. Please contact your Staples representative to learn more or to receive a customized lease quote for any upcoming purchase.

Pricing is valid for effective dates above and is otherwise subject to change. This proposal is confidential and meant for the client recipient above, any unauthorized review, use, disclosure or distribution is prohibited. Leasing Offer: 36 Mo FMV lease, your actual payment may vary. Lease subject to customer credit approval and lessor terms & conditions. Not all customers may qualify. Other restrictions may apply.



Proposal for:	
Company:	Magnolia Science Academy
Contact:	Rasul Monoshev
Phone:	
Email:	rmonoshev@magnoliapublicschools.org
Valid Date:	3/6/2019
Expires:	5/31/2019

Staples	
Date:	3/5/2019
Staples Contact:	Jonathan Knight
Phone:	() -
Email:	0
Notes:	

Qty.	Part No.	Product Description	UOM	Unit Price	Extended Price
6	IFP6560	Viewsonic 65IN VIEWBOARD 4K ULTRA HD IFP WITH INGLASS	EA	\$ 2,549.70	\$ 15,298.20
6	MI-373	Mount-It! Heavy Duty Mantel TV Mount Pull Down Mounting Bracket	EA	\$ 160.42	\$ 962.52
1		Wall Mounting Service	EA	\$ 4,188.89	\$ 4,188.89
	IFP-EW-60-02	ViewSonic Extended Warranty Extended service agreement - parts and labor (for display with 60"-69" diagonal size) - 2 years (4th/5th year) - on-site - for P/N: IFP6550-A, IFP6550-E1, IFP6550-E2, IFP6550-E3, IFP6560 **Included in the price of the Display.**			
		Sales Tax for Bell, CA of 9.5%			\$ 1,942.71
				<b>Total*</b>	\$ 23,997.88

\*Tax, eWaste and freight charges are additional where applicable

Notwithstanding anything to the contrary, Seller reserves the right to adjust pricing proportionate with the impact of tariffs, customs or duties imposed on the Products.

**You can lease this with monthly payments of \$ 702.18**

Leasing Options: Staples can help you overcome budget constraints, avoid obsolescence, and reduce upfront cost by leasing your IT assets. Please contact your Staples representative to learn more or to receive a customized lease quote for any upcoming purchase.

Pricing is valid for effective dates above and is otherwise subject to change. This proposal is confidential and meant for the client recipient above, any unauthorized review, use, disclosure or distribution is prohibited. Leasing Offer: 36 Mo FMV lease, your actual payment may vary. Lease subject to customer credit approval and lessor terms & conditions. Not all customers may qualify. Other restrictions may apply.





Proposal for:	
Company:	Magnolia Science Academy
Contact:	Rasul Monoshev
Phone:	
Email:	rmonoshev@magnoliapublicschools.org
Valid Date:	3/6/2019
Expires:	5/31/2019

Staples	
Date:	3/5/2019
Staples Contact:	Jonathan Knight
Phone:	() -
Email:	0
Notes:	

Qty.	Part No.	Product Description	UOM	Unit Price	Extended Price
		Per Request- this is the cost of installation separated out by request			
1		Wall Mounting Service- qty 1 unit for IPF7550 and 6560	EA	\$ 738.89	\$ 738.89
1		Cart Mounting Service- qty 1 unit for IPF7550 and 6560	EA	\$ 866.67	\$ 866.67
		Sales Tax for LA County, CA of 9.5%			\$ 152.53
				<b>Total*</b>	\$ 1,758.09

\*Tax, eWaste and freight charges are additional where applicable

Notwithstanding anything to the contrary, Seller reserves the right to adjust pricing proportionate with the impact of tariffs, customs or duties imposed on the Products.

**You can lease this with monthly payments of \$ 55.10**

Leasing Options: Staples can help you overcome budget constraints, avoid obsolescence, and reduce upfront cost by leasing your IT assets. Please contact your Staples representative to learn more or to receive a customized lease quote for any upcoming purchase.

Pricing is valid for effective dates above and is otherwise subject to change. This proposal is confidential and meant for the client recipient above, any unauthorized review, use, disclosure or distribution is prohibited. Leasing Offer: 36 Mo FMV lease, your actual payment may vary. Lease subject to customer credit approval and lessor terms & conditions. Not all customers may qualify. Other restrictions may apply.

Proposal for:	
Company:	Magnolia Science Academy
Contact:	Rasul Monoshev
Phone:	
Email:	rmonoshev@magnoliapublicschools.org
Valid Date:	3/6/2019
Expires:	5/31/2019

Staples	
Date:	3/5/2019
Staples Contact:	Jonathan Knight
Phone:	() -
Email:	0
Notes:	

Qty.	Part No.	Product Description	UOM	Unit Price	Extended Price
		Per Request- this is the cost of installation separated out by request			
1		Wall Mounting Service- qty 1 unit for IPF7550 and 6560	EA	\$ 738.89	\$ 738.89
1		Cart Mounting Service- qty 1 unit for IPF7550 and 6560	EA	\$ 866.67	\$ 866.67
		Sales Tax for San Diego, CA of 7.75%			\$ 124.43
				<b>Total*</b>	\$ 1,729.99

\*Tax, eWaste and freight charges are additional where applicable

Notwithstanding anything to the contrary, Seller reserves the right to adjust pricing proportionate with the impact of tariffs, customs or duties imposed on the Products.

**You can lease this with monthly payments of \$ 54.22**

Leasing Options: Staples can help you overcome budget constraints, avoid obsolescence, and reduce upfront cost by leasing your IT assets. Please contact your Staples representative to learn more or to receive a customized lease quote for any upcoming purchase.

Pricing is valid for effective dates above and is otherwise subject to change. This proposal is confidential and meant for the client recipient above, any unauthorized review, use, disclosure or distribution is prohibited. Leasing Offer: 36 Mo FMV lease, your actual payment may vary. Lease subject to customer credit approval and lessor terms & conditions. Not all customers may qualify. Other restrictions may apply.



## Limited Warranty

### ViewSonic® Limited Warranty

(Current Production Models. U.S.A. and Canada Only)

#### What the warranty covers:

ViewSonic warrants its products to be free from defects in material and workmanship during the warranty period. If a product proves to be defective in material or workmanship during the warranty period, ViewSonic will, at its sole option, repair or replace the product with a similar product. Replacement Product or parts may include remanufactured or refurbished parts or components. The replacement unit will be covered by the balance of the time remaining on the customer's original limited warranty. ViewSonic provides no warranty for any third-party software whether included with the product or installed by the customer, installation of any unauthorized hardware parts or components (e.g. Projector Lamps). (Please refer to: "[What the warranty does not cover](#)" section)

ViewSonic "A" Stock Product is defined as:

- Brand new, never been used products freshly received from factory in original packaging
- Packaging must be unopened (other than any cursory un-boxing/re-boxing for quality assurance inspection)

#### How long the warranty is effective:

1. ViewSonic Monitor carry a three (3) year limited warranty for parts, labor and LCD backlight from the purchase date. In order to receive warranty service, proof of purchase of the ViewSonic product is required. To obtain warranty service, please contact ViewSonic Customer Support.
2. ViewSonic Monitors are warranted with our LCD Pixel Performance Guarantee. Through this limited warranty, you are guaranteed high-quality screen performance with no more than the following improperly operating pixels, depending on the native panel resolutions.
  1. Panels with resolution smaller than 3840x2160: Three (3) improperly operating pixels with no more than two (2) bright or two (2) dark pixels.
  2. Panels with resolution 3840x2160 or higher: Eight (8) improperly operating pixels with no more than five (5) bright or five (5) dark pixels.

3. ViewSonic Projectors (unless otherwise specified) are warranted for three (3) years from the date of first consumer purchase for parts and labor and one (1) year limited lamp warranty. Lamp warranty is subject to terms and conditions, verification and approval. Applies to manufacturer's installed lamp only. All accessory lamps purchased separately are warranted for 90 days.
4. ViewSonic Desktop Virtualization products (unless otherwise specified) are warranted for three (3) year for parts and labor.
5. ViewSonic Large Format Display (LFD) products are warranted for three (3) years from the date of first consumer purchase for parts and labor.\*
6. ViewSonic ViewBoard Interactive Flat Panel display (IFP) products are warranted for three (3) years from the date of first consumer purchase for parts and labor.\*
7. ViewSonic Digital Kiosks and Billboards (ePoster) Products are warranted for one (1) year from the date of first consumer purchase for parts and labor.\*

\*All 42" and larger ViewSonic Display Products will receive onsite services in the U.S. and Canada with the following exceptions:

- If the service location of the defective unit is over 40 miles outside a major metropolitan area. The customer will be responsible to ship/transport the covered Product to the designated repair center;
  - If a defective unit is determined by the ViewSonic Technical Support staff to be a panel defect, or ViewSonic's Technician is unable to resolve the problem on-site, a replacement unit will be dispatched from ViewSonic's warehouse to customer's ship-to location (front door deliveries only). It is customer's responsibility to pack and ship/transport the covered Product to the designated repair center.
8. ViewSonic Media Player products (unless otherwise specified) are warranted for one (1) year for parts and labor.
  9. ViewSonic Slot-In PC products are warranted for one (1) year for parts and labor.
  10. ViewSonic accessory products carry limited warranties. See the product page for additional detail by model.
  11. All brand new ViewSonic products carry a thirty (30) day "Dead on Arrival" ("DOA") warranty policy for the first consumer purchaser. A new replacement unit will be provided if the Product is found to be non-operational within thirty (30) days of purchase and freight shall be covered both ways by ViewSonic.

### **Who the warranty protects:**

This warranty is valid only for the first consumer purchaser.

### **What the warranty does not cover:**

- Any product on which the serial number has been defaced, modified or removed.
- Damage, deterioration or malfunction resulting from:
  - a) Accident, misuse, neglect, fire, water, lightning, or other acts of nature, unauthorized product modification, or failure to follow instructions supplied with the product.
  - b) Repair or attempted repair by anyone not authorized by ViewSonic.
  - c) Damage to or loss of any programs, data or removable storage media.
  - d) Software or data loss occurring during repair or replacement.
  - e) Any damage of the product due to shipment.
  - f) Removal or installation of the product.

- g) Causes external to the product, such as electric power fluctuations or failure.
  - h) Use of supplies or parts not meeting ViewSonic's specifications.
  - i) Normal wear and tear.
  - j) Failure of owner to perform periodic product maintenance as stated in User Guide, such as cleaning of user-cleanable projector filters.
  - k) Any other cause which does not relate to a product defect.
  - l) Damage caused by static (non-moving) images displayed for lengthy periods of time (also referred to as image burn-in).
  - m) Software - Any third-party software included with the product or installed by the customer.
  - n) Hardware/Accessories/Parts/Components - Installation of any unauthorized hardware, accessories, consumable parts or components (e.g. Projector Lamps).
  - o) Damage to, or abuse of, the coating on the surface of the display through inappropriate cleaning as described in product User Guide.
  - p) The Product sold and labeled as "AS IS\*", "WITH ALL FAULTS" or similar disclaimer, including replacement of missing parts or accessories from those sales, or purchased through an unauthorized online seller.
- Removal, installation, and set-up service charges, including wall-mounting of product.

#### **How to obtain service:**

- **For general service support information, including download drivers, check RMA status, and FAQs, please visit us at**  
<https://www.viewsonic.com/us/customer-service/>
- **To obtain warranty service please start here:**  
[www.viewsonic.com/csform](http://www.viewsonic.com/csform)

#### **Limitation of implied warranties:**

TO THE EXTENT ALLOWED BY LOCAL LAW, THIS PRODUCT IS PROVIDED TO YOU "AS IS" WITHOUT WARRANTIES OR CONDITIONS OF ANY KIND, WHETHER ORAL OR WRITTEN, EXPRESS OR IMPLIED. VIEWSONIC SPECIFICALLY DISCLAIMS ANY IMPLIED WARRANTIES OR CONDITIONS OF MERCHANTABILITY, SATISFACTORY QUALITY, NON-INFRINGEMENT AND FITNESS FOR A PARTICULAR PURPOSE.

#### **Exclusion of damages:**

VIEWSONIC'S LIABILITY IS LIMITED TO THE COST OF REPAIR OR REPLACEMENT OF THE PRODUCT.

VIEWSONIC SHALL NOT BE LIABLE FOR:

- 1) DAMAGE TO OTHER PROPERTY CAUSED BY ANY DEFECTS IN THE PRODUCT,
- 2) DAMAGES BASED UPON INCONVENIENCE, LOST PROFIT, LOST DATA OR DOWNTIME COSTS, LOSS OF USE OF THE PRODUCT, LOSS OF TIME, LOSS OF PROFITS, LOSS OF BUSINESS OPPORTUNITY, LOSS OF GOODWILL, INTERFERENCE WITH BUSINESS RELATIONSHIPS, OR OTHER COMMERCIAL LOSS, EVEN IF ADVISED OF THE POSSIBILITY OF SUCH DAMAGES.
- 3) ANY OTHER DAMAGES, WHETHER DIRECT, SPECIAL, INCIDENTAL, CONSEQUENTIAL OR OTHERWISE.



4) ANY CLAIM AGAINST THE CUSTOMER BY ANY OTHER PARTY.

**Effect of local law:**

This warranty gives you specific legal rights, and you may also have other rights which vary from locality to locality. Some localities do not allow limitations on implied warranties and/or do not allow the exclusion of incidental or consequential damages, so the above limitations and exclusions may not apply to you.

**Sales outside the U.S.A. and Canada:**

For ViewSonic products sold outside the U.S. and Canada, contact your ViewSonic dealer or your region for more warranty information and service for your country. Look up [our locations here](#)



September 6, 2018

Staples Contract & Commercial, LLC ("Staples")  
500 Staples Drive  
Framingham, MA 01702  
Attn: Sean Greenberg  
Email: sean.greenberg@staples.com

**RE: Letter of Authorization**

To Whom It May Concern:

ViewSonic Corporation ("ViewSonic") is a worldwide provider of Visual Display Technology™ products under the brand name of ViewSonic®. ViewSonic does not have a reseller authorization program, as its products are generally available through distribution on the open market to all resellers.

This letter is to certify that Staples is authorized to sell ViewSonic products as a registered member of ViewSonic's Finch Club<sup>SM</sup> Reseller Partner Program. In order to become a member of this program, the reseller must submit documentation demonstrating to ViewSonic's satisfaction that they are licensed to conduct business in a particular state or province. The contract between the parties entitles the reseller access to special programs and benefits offered by ViewSonic, including marketing and technical support and warranty.

ViewSonic's Dun and Bradstreet number is 17-770-7973.

ViewSonic's point of contact for qualifying product(s) submitted for this solicitation is:

ViewSonic Corporation  
10 Pointe Drive  
Brea, CA 92821  
(909) 444-8888

By providing this letter, ViewSonic does not intend to be legally bound by the terms and conditions of any Request for Proposal, Request for Quotation, Contract, or any other legally binding document.

Any questions relating to ViewSonic's products should be directed to Jeff Shapiro at 561-756-5018 or [jeff.shapiro@viewsonic.com](mailto:jeff.shapiro@viewsonic.com).

Sincerely,

Sung Yi  
CFO



**MOUNT-IT!**  
Premium AV & Office Products

MI-373

## Fireplace TV Mount

ENHANCE YOUR DISPLAY THE DIGITAL WAY



Mount-It! Fireplace TV Mount is specifically designed to be installed over a fireplace mantel. This TV mount solves the typical problem with fireplace TV installations: when mounted over the fireplace, the TV is too high for comfortable viewing. By utilizing a state of the art height adjustment mechanism, our mantel TV mount lowers your TV for viewing and raises it back up when not in use - letting you enjoy both your fireplace and your TV.

- Constructed from solid steel to safely and sturdily hold 154 lbs.
- Gas spring mechanism assists in lifting and lowering the TV.
- Full motion design - tilt, swivel, rotate
- for ultimate viewing experience.



**A BETTER VIEWING EXPERIENCE.** Tilt, swivel or rotate for comfort.

**EASY INSTALLATION.** All hardware included.

**PREMIUM QUALITY.** Built to last.

MI-373

# Fireplace TV Mount

ENHANCE YOUR DISPLAY THE DIGITAL WAY



## SPECIFICATIONS

### FIREPLACE TV MOUNT

TV size range:	50" – 100"
Rotation:	+/-5°
Tilt:	-3°, +15°
Swivel:	+/-30°
VESA (millimeters):	200x200 – 800x600
Color:	Black
Load Capacity:	154 lbs

- Adjustable tilt and swivel offers maximum viewing flexibility
- Gas spring design for effortless movement
- Easy grip handle makes pull down a snap
- Folding design saves space
- Heavy load capacity
- Heavy-duty steel construction
- All hardware included for easy installation

MOUNT-IT.COM

Tel: 858.413.7670 • Fax: 858.762.3757

Email: [sales@mount-it.com](mailto:sales@mount-it.com)

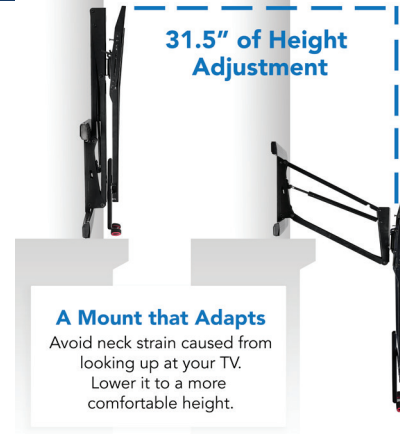

**MOUNT-IT!**  
Premium AV & Office Products



Proposal for:	
Company:	Magnolia Science Academy
Contact:	Rasul Monoshev
Phone:	
Email:	rmonoshev@magnoliapublicschools.org
Valid Date:	3/6/2019
Expires:	5/31/2019

Staples	
Date:	3/5/2019
Staples Contact:	Jonathan Knight
Phone:	() -
Email:	0
Notes:	

Qty.	Part No.	Product Description	UOM	Unit Price	Extended Price
		Per Request- this is the cost of installation separated out by request			
1		Wall Mounting Service- qty 1 unit for IPF7550 and 6560	EA	\$ 738.89	\$ 738.89
1		Cart Mounting Service- qty 1 unit for IPF7550 and 6560	EA	\$ 866.67	\$ 866.67
		Sales Tax for LA County, CA of 9.5%			\$ 152.53
				<b>Total*</b>	\$ 1,758.09

\*Tax, eWaste and freight charges are additional where applicable

Notwithstanding anything to the contrary, Seller reserves the right to adjust pricing proportionate with the impact of tariffs, customs or duties imposed on the Products.

**You can lease this with monthly payments of \$ 55.10**

Leasing Options: Staples can help you overcome budget constraints, avoid obsolescence, and reduce upfront cost by leasing your IT assets. Please contact your Staples representative to learn more or to receive a customized lease quote for any upcoming purchase.

Pricing is valid for effective dates above and is otherwise subject to change. This proposal is confidential and meant for the client recipient above, any unauthorized review, use, disclosure or distribution is prohibited. Leasing Offer: 36 Mo FMV lease, your actual payment may vary. Lease subject to customer credit approval and lessor terms & conditions. Not all customers may qualify. Other restrictions may apply.

Proposal for:	
Company:	Magnolia Science Academy
Contact:	Rasul Monoshev
Phone:	
Email:	rmonoshev@magnoliapublicschools.org
Valid Date:	3/6/2019
Expires:	5/31/2019

Staples	
Date:	3/5/2019
Staples Contact:	Jonathan Knight
Phone:	() -
Email:	0
Notes:	

Qty.	Part No.	Product Description	UOM	Unit Price	Extended Price
		Per Request- this is the cost of installation separated out by request			
1		Wall Mounting Service- qty 1 unit for IPF7550 and 6560	EA	\$ 738.89	\$ 738.89
1		Cart Mounting Service- qty 1 unit for IPF7550 and 6560	EA	\$ 866.67	\$ 866.67
		Sales Tax for San Diego, CA of 7.75%			\$ 124.43
				<b>Total*</b>	\$ 1,729.99

\*Tax, eWaste and freight charges are additional where applicable

Notwithstanding anything to the contrary, Seller reserves the right to adjust pricing proportionate with the impact of tariffs, customs or duties imposed on the Products.

**You can lease this with monthly payments of \$ 54.22**

Leasing Options: Staples can help you overcome budget constraints, avoid obsolescence, and reduce upfront cost by leasing your IT assets. Please contact your Staples representative to learn more or to receive a customized lease quote for any upcoming purchase.

Pricing is valid for effective dates above and is otherwise subject to change. This proposal is confidential and meant for the client recipient above, any unauthorized review, use, disclosure or distribution is prohibited. Leasing Offer: 36 Mo FMV lease, your actual payment may vary. Lease subject to customer credit approval and lessor terms & conditions. Not all customers may qualify. Other restrictions may apply.

## Agilant Solutions, Inc.

3 Seaview Blvd.  
Port Washington, NY 11050

**STAPLES**<sup>®</sup>  
Business Advantage

---

### Magnolia Public Schools

**Date**

March 5, 2019

**Services Performed By:**

Agilant Solutions, Inc.  
("Subcontractor")

---

This Statement of Work No. 201901-398175 (hereinafter the "SOW") is entered into as of March 5, 2019 ("SOW Effective Date") and is attached to, and made a part of, that certain Request for Proposal Response dated as of March 6, 2019 (the "Agreement") by and between Magnolia Public Schools ("Client") and Staples Contract & Commercial LLC ("Staples"). Subcontractor, as a subcontractor to Staples, will perform the services specified in this SOW in accordance with the terms herein. Staples acknowledges that it shall remain liable for the performance of this SOW by Subcontractor.

The terms of the Agreement are incorporated by reference into this SOW. Any capitalized terms not defined in this SOW shall have the meanings ascribed to them in the Agreement. In the event of any conflict or inconsistency between the terms of this SOW and the terms of the Agreement, the terms of this SOW shall govern and prevail. The exhibit(s) to this SOW, if any, shall be deemed to be a part hereof. In the event of any inconsistencies between the terms of the body of this SOW and the terms of the exhibit(s) hereto, the terms of the body of this SOW shall prevail.

## Project Description

Staples was asked to submit a Statement of Work to Client for the installation of interactive displays at two (2) of the Client's locations.

Addresses for the locations are as follows:

- MSA (1) - 18220 Sherman Way, Reseda; CA, 91335
- MSA (8) - 6411 Orchard Avenue; Bell, CA 90201



Staples was also asked to submit a Statement of Work to Client for the installation of interactive displays at ten (10) additional sites, to be utilized if the additional sites require any services up to June 30th, 2020.

Address for the locations are as follows:

- MSA (1) - 18238 Sherman Way, Reseda, CA 91335
- MSA (2) - 17125 Victory Blvd., Van Nuys, CA 91406
- MSA (3) - 1254 East Helmick Street, Carson, CA 90746
- MSA (4) - 11330 West Graham Place, Los Angeles, CA 90064
- MSA (5) - 18230 Kittridge St., Reseda, CA 91335
- MSA (6) - 3754 Dunn Dr., Los Angeles, CA 90034
- MSA (7) - 18355 Roscoe Boulevard, Northridge, CA 91325
- MSA (8) - 6411 Orchard Ave., Bell, CA 90201
- MSA () - Santa Ana 2840 W. 1st Street, Santa Ana, CA 92703
- MSA () - San Diego 6525 Estrella Ave., San Diego, CA 92120

Some or all of the Deliverables under this SOW shall be provided by Subcontractor. Any reference to the Subcontractor in this SOW will be provided on behalf of Staples.

## Scope of Work

---

Client desires the following scopes at MSA (1):

- **Option 1:** Twenty (20) 75" display and wall mount - mounting service labor.
- **Option 2:** Twenty (20) 75" display and a stand on a wheel.
- **Option 3:** Twenty (20) 65" display and wall mount - mounting service labor.
- **Option 4:** Twenty (20) 65" display and a stand on a wheel.

Project is estimated to take up to ten (10) days if technicians are allowed to work full eight (8) hour days during normal business hours.

Client desires the following scopes at MSA (8):

- **Option 1:** Six (6) 75" display and wall mount - mounting service labor.
- **Option 2:** Six (6) 75" display and a stand on a wheel.
- **Option 3:** Six (6) 65" display and wall mount - mounting service labor.
- **Option 4:** Six (6) 65" display and a stand on a wheel.

Project is estimated to take up to three (3) days if technicians are allowed to work full eight (8) hour days during normal business hours.

Client desires the following scopes at the ten (10) additional sites up to June 30<sup>th</sup>, 2020:

- **Option 1:** One (1) 75" display and wall mount - mounting service labor.
- **Option 2:** One (1) 75" display and a stand on a wheel.
- **Option 3:** One (1) 65" display and wall mount - mounting service labor.
- **Option 4:** One (1) 65" display and a stand on a wheel.

Project is estimated to take up to four (4) hours if technicians are allowed to work full eight (8) hour days during normal business hours.

Part No.	Product Description
IFP7550	Viewsonic 75IN VIEWBOARD 4K INTERACTIVE PANEL WITH 20-POINT
IFP6560	Viewsonic 65IN VIEWBOARD 4K ULTRA HD IFP WITH INGLASS
VB-STND-001	ViewSonic VB-STND-001 Cart (mount bracket) for interactive flat panel / LCD display - for ViewSonic CDE5561, CDE6561; ViewBoard IFP5550, IFP6550,
MI-373	Mount-IT TV Tilt Mount

## Subcontractor Responsibilities

---

All tasks listed under Scope of Work are Subcontractor responsibilities

## Client Responsibilities

---

- Provide project specific documentation, guides and configuration information.
- Provide technicians access to all areas required for successful installation/implementation.
  - Delayed access to installation areas may result in additional change ordered cost.
- Provide all hardware/software/materials required to complete the installation:
  - All mounts, screws, bolts and hardware required to fix wall mounts.
  - Low voltage cable, connectors and terminations.
  - Any wall prep needed for heavy screens that requires backing (wood behind mounting wall).
  - Any lift rentals for high ceilings will be Client's responsibility
- Prepare site and onsite contacts for technician arrival and installation accommodations.
- Ensure all hardware is onsite in dedicated install room prior to technician arrival.
- Provide a dedicated site contact for issue resolution and completion sign off.

## Pricing

---

### MSA (1):

Service: OPTION 1 & 3	Cost
Wall-mount twenty (20) 65" or 75" interactive displays to drywall	\$12,444.44
Service: OPTION 2 & 4	Cost
Assemble twenty (20) active stands/mobile carts. Mount twenty (20) 65" or 75" interactive displays onto carts	\$15,000.00

Travel for two (2) technicians limited to ten (10) visits each have been included in pricing. If trips exceed 10 visits, Client will be charged \$50.00 per additional visit, per technician.

### MSA (8):

MSA-8 Service: OPTION 1 & 3	Cost
Wall-mount six (6) 65" or 75" interactive displays to drywall	\$4,188.89
MSA-8 Service: OPTION 2 & 4	Cost
Assemble six (6) active stands/mobile carts. Mount six (6) 65" or 75" interactive displays onto carts	\$4,750.00

Travel for two (2) technicians limited to three (3) visits each have been included in pricing. If trips exceed 3 visits, Client will be charged \$50.00 per additional visit, per technician.

### Additional Locations:

MSA-8 Service: OPTION 1 & 3	Cost
Wall-mount one (1) 65" or 75" interactive displays to drywall	\$738.89
MSA-8 Service: OPTION 2 & 4	Cost
Assemble one (1) active stands/mobile carts. Mount one (1) 65" or 75" interactive displays onto carts	\$866.67

**Travel for two (2) technicians limited to one (1) visit each have been included in pricing. If trips exceed 1 visit, Client will be charged \$50.00 per additional visit, per technician.**

Our pricing includes all: limited travel, scheduling, administrative, project management and logistics costs. It is based on the information you provided and is contingent upon following this scope. Any deviation from the equipment list and understood scope of work to complete this scope will result in additional costs.

\*Out of scope hourly rates (starting at \$84.00 per hour per technician) are applied to activity outside the agreed upon SOW and out of the control of the technician and/or service provider. Examples include, but are not limited to, site access delay, equipment not onsite, network connectivity issues or configurations not applied by the installation technician.

Limitation of Liability: In no event shall the liability of Staples arising in connection with or under this SOW (whether under the theories of breach of contract, tort liability, misrepresentation, fraud, warranty, negligence, strict liability or any other theory of law) exceed the purchase price of the services and the SOW.

Limitation of Damages: Client shall in no event be entitled to, and Staples shall not be liable for indirect, special, incidental or consequential damages of any of any nature, including, but not limited to, loss of profit, promotional and/or manufacturing expenses, overhead, injury to reputation and/or loss of customers.

## Assumptions/Exclusions

---

- This scope & pricing assumes non-union labor.
- Business hours: Monday through Friday 9:00am to 5:00pm local time.
- After hours rates begin at 5:00pm and end at 8:00am local time.
- Weekends and holidays will increase business hour prices.
- This quote is for labor only and includes no materials outside of industry standard consumables.
- This SOW and quote assumes Client walls are drywall with metal or wood studs. Any structural issues will result in scope and quote change.
- SOW was prepared without surveying the site. No information regarding the school structure (pictures, ceiling heights, wall types) were provided. SOW assumes school is of standard structure.
- Modifications or changes to the equipment list or statement of work may result in additional costs or a change of project price.
- Cancellation of services by the Client within 24 hours of the scheduled service are subject to fee of up to 50% percent of the total project cost.
- Quote is valid for 30 days from the quote date.
- Pricing for the ten (10) additional locations is valid through June 30<sup>th</sup>, 2020

## Project Change Control Procedure

---

The following process will be followed if a change to this SOW is required:

- A Project Change Request Email (PCR) will be the vehicle for communicating change. The PCR must describe the change, the rationale for the change, and the effect the change will have on the project.
- The designated Project Manager of the requesting party (Staples or Client) will review the proposed change and determine whether to submit the request to the other party.
- Both Project Managers will review the proposed change and approve it or reject it. Subcontractor and Client will mutually agree upon any charges for such proposed change, if any. If the change is authorized, the Client Project Manager will confirm via email, which will constitute approval for the project change charges. Staples will invoice Client for any such charges.

## Acceptance

---

Each Deliverable or the completion of each described service covered by this SOW shall be subject to the following Acceptance Procedure:

- This SOW (with any Change Order) shall be the exclusive source of the criteria for whether any Deliverable or Service has been completed.
- Upon presentation of each Deliverable or completion of the Services or a defined phase thereof, Staples shall notify Client in writing. Presentation of a Deliverable constitutes notice of completion of that Deliverable and any Services performed in its creation. Any invoice concerning all or the final installment of any fees for Services in this SOW shall constitute notice of completion of the Services itemized on such invoice.
- Except when a longer review and acceptance period is provided in the Timeline in this SOW, Client shall have five (5) business days to review the completed Deliverable or to evaluate the completed Service. At the end of such period, Client shall either accept or reject the Service or Deliverable. Client shall not unreasonably reject or fail to accept a Deliverable or Service.
- If Client rejects a Deliverable or Service, Client shall provide a written notice specifically detailing each deficiency in the Deliverable or Service to enable correction by Subcontractor. Subcontractor shall have five (5) days to correct and re-deliver any rejected Deliverable or Service. If correction will reasonably require longer than 5 days, Subcontractor, upon notice, shall be entitled to extend this period as may be reasonably necessary so long as corrective work has commenced within the 5-day period. When the Deliverable or Service is re-submitted, this procedure will again apply thereto.
- If Client fails to respond within the permitted time, the Deliverable or Service shall be deemed Accepted.

- Rejection of any Deliverable shall not entitle Client to refund or return of any Fees paid in relation to any previously Accepted Service or Deliverable.
- It is expressly understood by Subcontractor that Client shall not be required to compensate Subcontractor for costs incurred by Subcontractor in correcting deficiencies attributable to Subcontractor's failure to perform the work in accordance with this SOW (with any Change Order).
- Terms and Conditions - [https://www.staples.com/sbd/content/help-center/policies-and-legal.html#10008\\_10](https://www.staples.com/sbd/content/help-center/policies-and-legal.html#10008_10)

**IN WITNESS WHEREOF**, the parties hereto have caused this SOW to be effective as of the day, month and year first written above.

MAGNOLIA PUBLIC SCHOOLS

STAPLES CONTRACT & COMMERCIAL LLC

By:

By:

Name:

Name:

Title:

Title:



VIA EMAIL

March 4, 2019

Digital Synergy Consulting, Inc.  
15021 Ventura Blvd #501  
Sherman Oaks, CA 91403  
Attn: Ken Hagopian  
Email: ken@dsc.la

Subject: Letter of Authorization

ViewSonic Corporation ("ViewSonic") is a worldwide provider of Visual Display Technology™ products under the brand name of ViewSonic®. ViewSonic does not have a reseller authorization program, as its products are generally available through distribution on the open market to all resellers.

This letter is to confirm that Digital Synergy Consulting, Inc. ("Reseller") is an authorized ViewSonic reseller under ViewSonic's Finch Club<sup>SM</sup> Reseller Partner Program. In order to become a member of this program, the reseller must submit documentation demonstrating to ViewSonic's satisfaction that they are licensed to conduct business in a particular state or province and maintain good financial and partnership standings. The contract between the parties entitles Reseller access to special programs, pricing and benefits, including marketing, technical and warranty support offered by ViewSonic.

By providing this letter, ViewSonic does not intend to be legally bound by the terms and conditions of any Request for Proposal, Request for Quotation, Contract, or any other legally binding document.

Any questions relating to ViewSonic's products should be directed to your ViewSonic Sales Representative.

Sincerely,

Sung Yi  
CFO

# MAGNOLIA PUBLIC SCHOOLS

---

*ATTN:* Rasul Monoshev

MSA 1\_8 Projector Bid

We appreciate the opportunity to bid on your project.

SPIN # 143036385 – Digital Synergy Consulting, Inc.  
FRN # 0024370165  
DIR # 1000012855  
CSLB C10 License # 1011924  
CA Business License Entity #: C2824489  
CA Small Business Certification ID: 1757859  
LA County Small Business Certification #: 1757859  
City of Los Angeles Small Business Certification # SLB – 3155

*Bidding Company:*

Digital Synergy Consulting, Inc.  
15021 Ventura Blvd #501  
Sherman Oaks, CA 91403

*Contact:*

Ken Hagopian  
818.647.9900 x210  
[ken@dsc.la](mailto:ken@dsc.la)





*Capabilities Statement:*

Digital Synergy is an IT consulting company located in Los Angeles, CA. We have implemented a number of high-density multi-building and multi-floor networks for both educational institutions and other enterprises. We have the experience to put in networks that work, and the tools to validate the design. We are HP, Brocade, Cisco, Meraki, Aruba and Ruckus partners.

We have spearheaded 1 to 1 initiatives for schools, and assist them in the design of their networks, wireless infrastructure, servers, and google apps.

We have been providing network services since 2006

*Project Scope and assumptions:*

We have also included some alternative options for the ViewSonic Interactive flat panel displays.

Interactive Displays:

- We have quoted both ViewSonic models as requested by the school
- We have quoted the mounts requested by the school
- We have quoted the ViewSonic trolley cart as well.

\*\* The school has requested part number IFP6560 which is not typical used in EDU. We have quoted it as requested but also quoted the IFP6550 which is generally used in EDU. We can have a call with the ViewSonic engineer for clarification on the differences.

Warranty for 4th and 5th Year INCLUDED.

\*\* We can lease all this equipment as well so payments can be spread out over multiple years.



# Digital Synergy Consulting Inc. Quote



From: Ken Hagopian  
 Digital Synergy Consulting Inc.  
 15021 Ventura Blvd. #501  
 Sherman Oaks, CA 91403

(818) 647-9900  
 Ken@DigitalSynergyIT.com

Prepared for: Rasul Monoshev  
 Magnolia Public Schools  
 18238 Sherman Way  
 Reseda, CA 91335  
 United States  
  
 rmonoshev@magnoliapublicschools.org

Quantity Description		Unit Price	Ext. Price
1.00	Note: MSA 1 Viewsonic IFP6550	\$0.00	\$0.00
20.00	VIEWSONIC : ViewBoard IFP6550-E1 bundle includes the following items: - ViewBoard IFP6550 4K Interactive display - LB-WIFI-001 Wireless AC adapter - WMK-047-2 wall mount IFP6550-E1 VIEWSONIC : 60 -69inch Interactive Display Extended On-Site Repair Warranty for 4th and 5th Year	\$1,875.00	\$37,500.00
		<b>Subtotal:</b>	<b>\$37,500.00</b>
		<b>Sales Tax:</b>	<b>\$2,906.25</b>
		<b>Total:</b>	<b>\$40,406.25</b>

Thank you, We appreciate the opportunity to quote your business.  
<http://www.dsc.la>

Signature: \_\_\_\_\_

Date: \_\_\_\_\_

# Digital Synergy Consulting Inc. Quote



From: Ken Hagopian  
 Digital Synergy Consulting Inc.  
 15021 Ventura Blvd. #501  
 Sherman Oaks, CA 91403

(818) 647-9900  
 Ken@DigitalSynergyIT.com

Prepared for: Rasul Monoshev  
 Magnolia Public Schools  
 18238 Sherman Way  
 Reseda, CA 91335  
 United States  
  
 rmonoshev@magnoliapublicschools.org

Quantity Description		Unit Price	Ext. Price
1.00	Note: MSA 1 Viewsonic IFP6550 WITH Cart Bundle	\$0.00	\$0.00
20.00	VIEWSONIC : ViewBoard IFP6550-E2 bundle includes the following items: - ViewBoard IFP6550 4K Interactive display - LB-WIFI-001 Wireless AC adapter - VB- STND-001 Mobile trolley cart IFP6550-E2 VIEWSONIC : 60 -69inch Interactive Display Extended On-Site Repair Warranty for 4th and 5th Year	\$2,189.00	\$43,780.00
		<b>Subtotal:</b>	<b>\$43,780.00</b>
		<b>Sales Tax:</b>	<b>\$3,392.95</b>
		<b>Total:</b>	<b>\$47,172.95</b>

Thank you, We appreciate the opportunity to quote your business.  
<http://www.dsc.la>

Signature: \_\_\_\_\_

Date: \_\_\_\_\_

# Digital Synergy Consulting Inc. Quote



From: Ken Hagopian  
 Digital Synergy Consulting Inc.  
 15021 Ventura Blvd. #501  
 Sherman Oaks, CA 91403

(818) 647-9900  
 Ken@DigitalSynergyIT.com

Prepared for: Rasul Monoshev  
 Magnolia Public Schools  
 18238 Sherman Way  
 Reseda, CA 91335  
 United States

rmonoshev@magnoliapublicschools.org

Quantity Description		Unit Price	Ext. Price
1.00	Note: MSA 1 Viewsonic IFP6560 *** This unit NOT typically used in EDU ***	\$0.00	\$0.00
20.00	VIEWSONIC : 65inch ViewBoard 4K Interactive Flat Panel with InGlass Technology IFP6560. Pricing expires on 6/1/19 *** This unit NOT typically used in EDU *** VIEWSONIC : 60 -69inch Interactive Display Extended On-Site Repair Warranty for 4th and 5th Year	\$2,720.00	\$54,400.00
		<b>Subtotal:</b>	<b>\$54,400.00</b>
		<b>Sales Tax:</b>	<b>\$4,216.00</b>
		<b>Total:</b>	<b>\$58,616.00</b>

Thank you, We appreciate the opportunity to quote your business.  
<http://www.dsc.la>

Signature: \_\_\_\_\_

Date: \_\_\_\_\_

# Digital Synergy Consulting Inc. Quote



From: Ken Hagopian  
 Digital Synergy Consulting Inc.  
 15021 Ventura Blvd. #501  
 Sherman Oaks, CA 91403

(818) 647-9900  
 Ken@DigitalSynergyIT.com

Prepared for: Rasul Monoshev  
 Magnolia Public Schools  
 18238 Sherman Way  
 Reseda, CA 91335  
 United States  
  
 rmonoshev@magnoliapublicschools.org

Quantity Description		Unit Price	Ext. Price
1.00	Note: MSA 1 Viewsonic IFP6560 *** This unit NOT typically used in EDU *** With Cart	\$0.00	\$0.00
20.00	VIEWSONIC : 65inch ViewBoard 4K Interactive Flat Panel with InGlass Technology IFP6560. Pricing expires on 6/1/19 *** This unit NOT typically used in EDU *** VIEWSONIC : 60 -69inch Interactive Display Extended On-Site Repair Warranty for 4th and 5th Year	\$2,720.00	\$54,400.00
20.00	VIEWSONIC : Featuring a convenient storage tray and an included mounting bracket, the VB-STND-001 is a mobile trolley cart ideal for ViewSonic commercial displays, and ViewBoard interactive flat panel displays. VB-STND-001	\$400.00	\$8,000.00
		<b>Subtotal:</b>	<b>\$62,400.00</b>
		<b>Sales Tax:</b>	<b>\$4,836.00</b>
		<b>Total:</b>	<b>\$67,236.00</b>

Thank you, We appreciate the opportunity to quote your business.  
<http://www.dsc.la>

Signature: \_\_\_\_\_

Date: \_\_\_\_\_

# Digital Synergy Consulting Inc. Quote



From: Ken Hagopian  
 Digital Synergy Consulting Inc.  
 15021 Ventura Blvd. #501  
 Sherman Oaks, CA 91403

(818) 647-9900  
 Ken@DigitalSynergyIT.com

Prepared for: Rasul Monoshev  
 Magnolia Public Schools  
 18238 Sherman Way  
 Reseda, CA 91335  
 United States  
  
 rmonoshev@magnoliapublicschools.org

Quantity Description		Unit Price	Ext. Price
1.00	Note: MSA 1 Viewsonic IFP7550	\$0.00	\$0.00
20.00	VIEWSONIC : ViewBoard IFP7550-E1 bundle includes the following items: - ViewBoard IFP7550 4K Interactive display - LB-WIFI-001 Wireless AC adapter - WMK-047-2 wall mount IFP7550-E1 VIEWSONIC : 70- 79inch Interactive Display Extended On-Site Repair Warranty for 4th and 5th Year	\$2,800.00	\$56,000.00
		<b>Subtotal:</b>	<b>\$56,000.00</b>
		<b>Sales Tax:</b>	<b>\$4,340.00</b>
		<b>Total:</b>	<b>\$60,340.00</b>

Thank you, We appreciate the opportunity to quote your business.  
<http://www.dsc.la>

Signature: \_\_\_\_\_

Date: \_\_\_\_\_

# Digital Synergy Consulting Inc. Quote



From: Ken Hagopian  
 Digital Synergy Consulting Inc.  
 15021 Ventura Blvd. #501  
 Sherman Oaks, CA 91403

(818) 647-9900  
 Ken@DigitalSynergyIT.com

Prepared for: Rasul Monoshev  
 Magnolia Public Schools  
 18238 Sherman Way  
 Reseda, CA 91335  
 United States  
  
 rmonoshev@magnoliapublicschools.org

Quantity Description		Unit Price	Ext. Price
1.00	Note: MSA 1 Viewsonic IFP7550 Cart Bundle	\$0.00	\$0.00
20.00	VIEWSONIC : ViewBoard IFP7550-E2 bundle includes the following items: - ViewBoard IFP7550 4K Interactive display - LB-WIFI-001 Wireless AC adapter - VB- STND-001 Mobile trolley cart IFP7550-E2 VIEWSONIC : 70- 79inch Interactive Display Extended On-Site Repair Warranty for 4th and 5th Year	\$3,150.00	\$63,000.00
		<b>Subtotal:</b>	<b>\$63,000.00</b>
		<b>Sales Tax:</b>	<b>\$4,882.50</b>
		<b>Total:</b>	<b>\$67,882.50</b>

Thank you, We appreciate the opportunity to quote your business.  
<http://www.dsc.la>

Signature: \_\_\_\_\_

Date: \_\_\_\_\_

**Digital Synergy Consulting Inc.  
Quote**



From: Ken Hagopian  
Digital Synergy Consulting Inc.  
15021 Ventura Blvd. #501  
Sherman Oaks, CA 91403

(818) 647-9900  
Ken@DigitalSynergyIT.com

Prepared for: Rasul Monoshev  
Magnolia Public Schools  
18238 Sherman Way  
Reseda, CA 91335  
United States

rmonoshev@magnoliapublicschools.org

Quantity Description		Unit Price	Ext. Price
1.00	Note: MSA 1 Hovertrack	\$0.00	\$0.00
20.00	Track Technology Systems Hovermount Flat Panel Mount, height adjustable up to 125 lbs.	\$400.00	\$8,000.00
1.00	Shipping LTL	\$750.00	\$750.00
		<b>Subtotal:</b>	<b>\$8,750.00</b>
		<b>Sales Tax:</b>	<b>\$620.00</b>
		<b>Total:</b>	<b>\$9,370.00</b>

Thank you, We appreciate the opportunity to quote your business.  
<http://www.dsc.la>

Signature: \_\_\_\_\_

Date: \_\_\_\_\_



Digital Synergy Consulting Inc.  
Quote



From: Ken Hagopian  
Digital Synergy Consulting Inc.  
15021 Ventura Blvd. #501  
Sherman Oaks, CA 91403

(818) 647-9900  
Ken@DigitalSynergyIT.com

Prepared for: Rasul Monoshev  
Magnolia Public Schools  
18238 Sherman Way  
Reseda, CA 91335  
United States

rmonoshev@magnoliapublicschools.org

Quantity Description		Unit Price	Ext. Price
1.00	Note: MSA 1 Installation	\$0.00	\$0.00
20.00	Mounting of equipment	\$165.00	\$3,300.00
		<b>Subtotal:</b>	<b>\$3,300.00</b>
		<b>Sales Tax:</b>	<b>\$0.00</b>
		<b>Total:</b>	<b>\$3,300.00</b>

Thank you, We appreciate the opportunity to quote your business.  
<http://www.dsc.la>

Signature: \_\_\_\_\_

Date: \_\_\_\_\_

# Digital Synergy Consulting Inc. Quote



From: Ken Hagopian  
 Digital Synergy Consulting Inc.  
 15021 Ventura Blvd. #501  
 Sherman Oaks, CA 91403

(818) 647-9900  
 Ken@DigitalSynergyIT.com

Prepared for: Rasul Monoshev  
 Magnolia Public Schools  
 18238 Sherman Way  
 Reseda, CA 91335  
 United States  
  
 rmonoshev@magnoliapublicschools.org

Quantity Description		Unit Price	Ext. Price
1.00	Note: MSA 8 Viewsonic IFP6550	\$0.00	\$0.00
6.00	VIEWSONIC : ViewBoard IFP6550-E1 bundle includes the following items: - ViewBoard IFP6550 4K Interactive display - LB-WIFI-001 Wireless AC adapter - WMK-047-2 wall mount IFP6550-E1 VIEWSONIC : 60 -69inch Interactive Display Extended On-Site Repair Warranty for 4th and 5th Year	\$1,875.00	\$11,250.00
		<b>Subtotal:</b>	<b>\$11,250.00</b>
		<b>Sales Tax:</b>	<b>\$871.88</b>
		<b>Total:</b>	<b>\$12,121.88</b>

Thank you, We appreciate the opportunity to quote your business.  
<http://www.dsc.la>

Signature: \_\_\_\_\_

Date: \_\_\_\_\_

# Digital Synergy Consulting Inc. Quote



From: Ken Hagopian  
 Digital Synergy Consulting Inc.  
 15021 Ventura Blvd. #501  
 Sherman Oaks, CA 91403

(818) 647-9900  
 Ken@DigitalSynergyIT.com

Prepared for: Rasul Monoshev  
 Magnolia Public Schools  
 18238 Sherman Way  
 Reseda, CA 91335  
 United States  
  
 rmonoshev@magnoliapublicschools.org

Quantity Description		Unit Price	Ext. Price
1.00	Note: MSA 8 Viewsonic IFP6550 WITH Cart Bundle	\$0.00	\$0.00
6.00	VIEWSONIC : ViewBoard IFP6550-E2 bundle includes the following items: - ViewBoard IFP6550 4K Interactive display - LB-WIFI-001 Wireless AC adapter - VB- STND-001 Mobile trolley cart IFP6550-E2 VIEWSONIC : 60 -69inch Interactive Display Extended On-Site Repair Warranty for 4th and 5th Year	\$2,189.00	\$13,134.00
		<b>Subtotal:</b>	<b>\$13,134.00</b>
		<b>Sales Tax:</b>	<b>\$1,017.89</b>
		<b>Total:</b>	<b>\$14,151.89</b>

Thank you, We appreciate the opportunity to quote your business.  
<http://www.dsc.la>

Signature: \_\_\_\_\_

Date: \_\_\_\_\_

# Digital Synergy Consulting Inc. Quote



From: Ken Hagopian  
 Digital Synergy Consulting Inc.  
 15021 Ventura Blvd. #501  
 Sherman Oaks, CA 91403

(818) 647-9900  
 Ken@DigitalSynergyIT.com

Prepared for: Rasul Monoshev  
 Magnolia Public Schools  
 18238 Sherman Way  
 Reseda, CA 91335  
 United States

rmonoshev@magnoliapublicschools.org

Quantity	Description	Unit Price	Ext. Price
1.00	Note: MSA 8 Viewsonic IFP6560 *** This unit NOT typically used in EDU ***	\$0.00	\$0.00
6.00	VIEWSONIC : 65inch ViewBoard 4K Interactive Flat Panel with InGlass Technology IFP6560. Pricing expires on 6/1/19 *** This unit NOT typically used in EDU *** VIEWSONIC : 60 -69inch Interactive Display Extended On-Site Repair Warranty for 4th and 5th Year	\$2,720.00	\$16,320.00
		<b>Subtotal:</b>	<b>\$16,320.00</b>
		<b>Sales Tax:</b>	<b>\$1,264.80</b>
		<b>Total:</b>	<b>\$17,584.80</b>

Thank you, We appreciate the opportunity to quote your business.  
<http://www.dsc.la>

Signature: \_\_\_\_\_

Date: \_\_\_\_\_

# Digital Synergy Consulting Inc. Quote



From: Ken Hagopian  
 Digital Synergy Consulting Inc.  
 15021 Ventura Blvd. #501  
 Sherman Oaks, CA 91403

(818) 647-9900  
 Ken@DigitalSynergyIT.com

Prepared for: Rasul Monoshev  
 Magnolia Public Schools  
 18238 Sherman Way  
 Reseda, CA 91335  
 United States

rmonoshev@magnoliapublicschools.org

Quantity Description		Unit Price	Ext. Price
1.00	Note: MSA 8 Viewsonic IFP6560 *** This unit NOT typically used in EDU *** With Cart	\$0.00	\$0.00
6.00	VIEWSONIC : 65inch ViewBoard 4K Interactive Flat Panel with InGlass Technology IFP6560. Pricing expires on 6/1/19 *** This unit NOT typically used in EDU *** VIEWSONIC : 60 -69inch Interactive Display Extended On-Site Repair Warranty for 4th and 5th Year	\$2,720.00	\$16,320.00
6.00	VIEWSONIC : Featuring a convenient storage tray and an included mounting bracket, the VB-STND-001 is a mobile trolley cart ideal for ViewSonic commercial displays, and ViewBoard interactive flat panel displays. VB-STND-001	\$400.00	\$2,400.00
		<b>Subtotal:</b>	<b>\$18,720.00</b>
		<b>Sales Tax:</b>	<b>\$1,450.80</b>
		<b>Total:</b>	<b>\$20,170.80</b>

Thank you, We appreciate the opportunity to quote your business.  
<http://www.dsc.la>

Signature: \_\_\_\_\_

Date: \_\_\_\_\_

Digital Synergy Consulting Inc.  
Quote



From: Ken Hagopian  
Digital Synergy Consulting Inc.  
15021 Ventura Blvd. #501  
Sherman Oaks, CA 91403

(818) 647-9900  
Ken@DigitalSynergyIT.com

Prepared for: Rasul Monoshev  
Magnolia Public Schools  
18238 Sherman Way  
Reseda, CA 91335  
United States

rmonoshev@magnoliapublicschools.org

Quantity Description		Unit Price	Ext. Price
1.00	Note: MSA 8 Viewsonic IFP7550	\$0.00	\$0.00
6.00	VIEWSONIC : ViewBoard IFP7550-E1 bundle includes the following items: - ViewBoard IFP7550 4K Interactive display - LB-WIFI-001 Wireless AC adapter - WMK-047-2 wall mount IFP7550-E1 VIEWSONIC : 70- 79inch Interactive Display Extended On-Site Repair Warranty for 4th and 5th Year	\$2,800.00	\$16,800.00
		<b>Subtotal:</b>	<b>\$16,800.00</b>
		<b>Sales Tax:</b>	<b>\$1,302.00</b>
		<b>Total:</b>	<b>\$18,102.00</b>

Thank you, We appreciate the opportunity to quote your business.  
<http://www.dsc.la>

Signature: \_\_\_\_\_

Date: \_\_\_\_\_

**Digital Synergy Consulting Inc.  
Quote**



From: Ken Hagopian  
Digital Synergy Consulting Inc.  
15021 Ventura Blvd. #501  
Sherman Oaks, CA 91403

(818) 647-9900  
Ken@DigitalSynergyIT.com

Prepared for: Rasul Monoshev  
Magnolia Public Schools  
18238 Sherman Way  
Reseda, CA 91335  
United States  
  
rmonoshev@magnoliapublicschools.org

Quantity Description		Unit Price	Ext. Price
1.00	Note: MSA 8 Viewsonic IFP7550 Cart Bundle	\$0.00	\$0.00
6.00	VIEWSONIC : ViewBoard IFP7550-E2 bundle includes the following items: - ViewBoard IFP7550 4K Interactive display - LB-WIFI-001 Wireless AC adapter - VB- STND-001 Mobile trolley cart IFP7550-E2 VIEWSONIC : 70- 79inch Interactive Display Extended On-Site Repair Warranty for 4th and 5th Year	\$3,150.00	\$18,900.00
		<b>Subtotal:</b>	<b>\$18,900.00</b>
		<b>Sales Tax:</b>	<b>\$1,464.75</b>
		<b>Total:</b>	<b>\$20,364.75</b>

Thank you, We appreciate the opportunity to quote your business.  
<http://www.dsc.la>

Signature: \_\_\_\_\_

Date: \_\_\_\_\_

**Digital Synergy Consulting Inc.  
Quote**



From: Ken Hagopian  
Digital Synergy Consulting Inc.  
15021 Ventura Blvd. #501  
Sherman Oaks, CA 91403

(818) 647-9900  
Ken@DigitalSynergyIT.com

Prepared for: Rasul Monoshev  
Magnolia Public Schools  
18238 Sherman Way  
Reseda, CA 91335  
United States

rmonoshev@magnoliapublicschools.org

Quantity Description		Unit Price	Ext. Price
1.00	Note: MSA 8 Hovertrack	\$0.00	\$0.00
6.00	Track Technology Systems Hovermount Flat Panel Mount, height adjustable up to 125 lbs.	\$400.00	\$2,400.00
1.00	Shipping LTL	\$750.00	\$750.00
		<b>Subtotal:</b>	<b>\$3,150.00</b>
		<b>Sales Tax:</b>	<b>\$186.00</b>
		<b>Total:</b>	<b>\$3,336.00</b>

Thank you, We appreciate the opportunity to quote your business.  
<http://www.dsc.la>

Signature: \_\_\_\_\_

Date: \_\_\_\_\_



Digital Synergy Consulting Inc.  
Quote



From: Ken Hagopian  
Digital Synergy Consulting Inc.  
15021 Ventura Blvd. #501  
Sherman Oaks, CA 91403

(818) 647-9900  
Ken@DigitalSynergyIT.com

Prepared for: Rasul Monoshev  
Magnolia Public Schools  
18238 Sherman Way  
Reseda, CA 91335  
United States

rmonoshev@magnoliapublicschools.org

Quantity Description		Unit Price	Ext. Price
1.00	Note: MSA 8 Installation	\$0.00	\$0.00
6.00	Mounting of equipment	\$165.00	\$990.00
		<b>Subtotal:</b>	<b>\$990.00</b>
		<b>Sales Tax:</b>	<b>\$0.00</b>
		<b>Total:</b>	<b>\$990.00</b>

Thank you, We appreciate the opportunity to quote your business.  
<http://www.dsc.la>

Signature: \_\_\_\_\_

Date: \_\_\_\_\_

### *Similar Project Experience & References:*

1. **La Canada Unified School District** – Wireless network upgrade. Replaced existing and added new access points. Certified existing cabling, installed new cabling. Indoor and outdoor access points. Also performed a heatmap to validate wireless network. District wide project
  - a. Jamie Lee Lewsadder - Director of IT
  - b. (818) 486-8963 - [JLewsadder@lcsud.net](mailto:JLewsadder@lcsud.net)
2. **Campbell Union School District** – Network upgrade - District wide Cat 6 cabling 12 School sites.
  - a. Trevor Walker
  - b. (408) 364-4200 x7161 - [TWalker@campbellusd.org](mailto:TWalker@campbellusd.org)
3. **City of Inglewood** – City Libraries & Park Wi-Fi: Cabling and certification in all city libraries, installation of Ruckus Access points, HP Switches and SonicWALL firewall devices. Heatmaps, and testing of the entire environment. Park wireless installation.
  - a. Chris Eckhard
  - b. (310) 412-5534 - [cleckhard@cityofinglewood.org](mailto:cleckhard@cityofinglewood.org)
4. **Oak Park Unified School District** – District wide replacement of access points with Ruckus equipment. Assistance in configuration. Project duration Compressed time table 2 weeks.
  - a. Enoch Kwok - Director of Technology
  - b. (818) 735-3201 - [ekwok@opusd.org](mailto:ekwok@opusd.org)
5. **Magnolia Science Academy Public Schools** – New school construction. IDF. MDF, cabling, fiber cabling, installed access points, projectors, security cameras, PA system.
  - a. Rasul Monoshev IT Director
  - b. (714) 892-5066 x102 - [rmonoshev@magnoliapublicschools.org](mailto:rmonoshev@magnoliapublicschools.org)
6. **Sherman Indian High School – Bureau of Indian Education** – Campus wide cabling throughout 10 buildings. Network certification, Design and installation of wireless access points throughout the campus, including wireless support for outdoor gather areas. Installation and configuration of HP switches. Wireless heatmap and validation. Project compressed time frame 2 weeks.
  - a. Terry Longenecker IT Coordinator or Lorna Hoffs
  - b. (951) 276-6325 - [Terry.Longenecker@BIE.EDU](mailto:Terry.Longenecker@BIE.EDU) or [Lorna.Hoffs@bie.edu](mailto:Lorna.Hoffs@bie.edu)
7. **Multicultural Learning Center**: Multiple Projects over multiple years – cabling site wide, replacing aging equipment with new HP switches, Ruckus wireless controller, and Ruckus access points. Create VLANs, reconfigure network, implement high density campus wide wireless network, test, validate, and train. New building construction.
  - a. Saira Salazar-Martinez
  - b. (818) 716-5783 ext. 222 - [saira@mlccharter.org](mailto:saira@mlccharter.org)
8. **The Archer School for Girls**: Multiple projects over multiple years – cabling school wide, replace aging Switches with new switches, wireless controller, and Access points. Create VLANs as required, implement high density campus wide wireless network, test, validate, train. Multiple Project starting from 2009
  - a. John Chen - Director of Information Technology
  - b. (310) 873-7068 - [johnchen@archer.org](mailto:johnchen@archer.org)
9. **MEND (Meet each need with Dignity)**: Multiple projects over many years since 2008. Cabling site wide, replace network switches in multiple locations, implement new firewalls in multiple locations, virtualization of servers, implemented new phone system.
  - a. Scott Mikels - Chief Financial Officer
  - b. (818) 686-7353 - [scott@mendpoverty.org](mailto:scott@mendpoverty.org)



Digital Synergy will implement a robust, easy to and secure network system.

We look forward to providing your organization excellent service to aid in the stability and growth of your school.

We appreciate the opportunity to bid on your project.

---

Ken Hagopian  
CEO  
Digital Synergy Consulting, Inc.





CAL WEST VISUALS, INC.

# Quote 481

Joe Sweigart

PO Box 53571

Irvine, CA, 92619

513.404.9354

[Joseph@calwestvisual.com](mailto:Joseph@calwestvisual.com)

EFFECTIVE FROM: March 6, 2019

May 5, 2019

**Customer** Rasul Monoshev

[rMonoshev@magnoliapublicschools.org](mailto:rMonoshev@magnoliapublicschools.org)

CA Small Business Cert# 21611

Magnolia Science Academy

250 E 1st St, Suite 1500

Los Angeles, CA, 90012

213-362-9588

SALESPERSON	JOB	SHIPPING METHOD	SHIPPING TERMS	DELIVERY DATE	DUE DATE
Joe Sweigart	Magnolia Viewsonic	Ground	Ground with liftgate	As scheduled	As scheduled

QTY	ITEM #	DESCRIPTION	UNIT PRICE	LINE TOTAL
6.00	ifp6550	65" Viewsonic Viewboard	1,864.16	\$ 11,184.96
6.00	Hovermount	Hovermount Flat Panel Mount	410.00	\$ 2,460.00
6.00	Install	Install wall mount and mount display	300.00	\$ 1,800.00
6.00	IFP-EW-60-02	Viewsonic 4/5 year extended warranty	1.00	\$ 6.00
1.00	PD	1 hour of PD completed by a former teacher	-	\$ -
			Tax 9.5%	1,296.27
			Shipping	200.00
				16,947.23



CAL WEST VISUALS, INC.

# Quote 482

Joe Sweigart

PO Box 53571

Irvine, CA, 92619

513.404.9354

[Joseph@calwestvisual.com](mailto:Joseph@calwestvisual.com)

EFFECTIVE FROM: March 6, 2019

May 5, 2019

**Customer** Rasul Monoshev

[rMonoshev@magnoliapublicschools.org](mailto:rMonoshev@magnoliapublicschools.org)

CA Small Business Cert# 21611

Magnolia Science Academy

250 E 1st St, Suite 1500

Los Angeles, CA, 90012

213-362-9588

SALESPERSON	JOB	SHIPPING METHOD	SHIPPING TERMS	DELIVERY DATE	DUE DATE
Joe Sweigart	Magnolia Viewsonic	Ground	Ground with liftgate	As scheduled	As scheduled

QTY	ITEM #	DESCRIPTION	UNIT PRICE	LINE TOTAL
20.00	ifp6550	65" Viewsonic Viewboard	1,864.16	\$ 37,283.20
20.00	Hovermount	Hovermount Flat Panel Mount	410.00	\$ 8,200.00
20.00	Install	Install wall mount and mount display	300.00	\$ 6,000.00
20.00	IFP-EW-60-02	Viewsonic 4/5 year extended warranty	1.00	\$ 20.00
1.00	PD	1 hour of PD completed by a former teacher	-	\$ -
			Tax 9.5%	4,320.90
			Shipping	550.00
				56,374.10



CAL WEST VISUALS, INC.

# Quote 483

Joe Sweigart

PO Box 53571

Irvine, CA, 92619

513.404.9354

[Joseph@calwestvisual.com](mailto:Joseph@calwestvisual.com)

EFFECTIVE FROM: March 6, 2019

May 5, 2019

**Customer** Rasul Monoshev

[rMonoshev@magnoliapublicschools.org](mailto:rMonoshev@magnoliapublicschools.org)

CA Small Business Cert# 21611

Magnolia Science Academy

250 E 1st St, Suite 1500

Los Angeles, CA, 90012

213-362-9588

SALESPERSON	JOB	SHIPPING METHOD	SHIPPING TERMS	DELIVERY DATE	DUE DATE
Joe Sweigart	Magnolia Viewsonic	Ground	Ground with liftgate	As scheduled	As scheduled

QTY	ITEM #	DESCRIPTION	UNIT PRICE	LINE TOTAL
20.00	ifp6550	65" Viewsonic Viewboard	1,864.16	\$ 37,283.20
20.00	VB-STND-001	Viewsonic Rolling Trolley Cart	382.00	\$ 7,640.00
20.00	Install	Build rolling cart and install display	250.00	\$ 5,000.00
20.00	IFP-EW-60-02	Viewsonic 4/5 year extended warranty	1.00	\$ 20.00
1.00	PD	1 hour of PD completed by a former teacher	-	\$ -
			Tax 9.5%	4,267.70
			Shipping	-
				54,210.90



CAL WEST VISUALS, INC.

# Quote 484

Joe Sweigart

PO Box 53571

Irvine, CA, 92619

513.404.9354

[Joseph@calwestvisual.com](mailto:Joseph@calwestvisual.com)

EFFECTIVE FROM: March 6, 2019

May 5, 2019

**Customer** Rasul Monoshev

[rMonoshev@magnoliapublicschools.org](mailto:rMonoshev@magnoliapublicschools.org)

CA Small Business Cert# 21611

Magnolia Science Academy

250 E 1st St, Suite 1500

Los Angeles, CA, 90012

213-362-9588

SALESPERSON	JOB	SHIPPING METHOD	SHIPPING TERMS	DELIVERY DATE	DUE DATE
Joe Sweigart	Magnolia Viewsonic	Ground	Ground with liftgate	As scheduled	As scheduled

QTY	ITEM #	DESCRIPTION	UNIT PRICE	LINE TOTAL
6.00	ifp6550	65" Viewsonic Viewboard	1,864.16	\$ 11,184.96
6.00	VB-STND-001	Viewsonic Rolling Trolley Cart	382.00	\$ 2,292.00
6.00	Install	Build rolling cart and install display	250.00	\$ 1,500.00
6.00	IFP-EW-60-02	Viewsonic 4/5 year extended warranty	1.00	\$ 6.00
1.00	PD	1 hour of PD completed by a former teacher	-	\$ -
			Tax 9.5%	1,280.31
			Shipping	-
				16,263.27



CAL WEST VISUALS, INC.

# Quote 485

Joe Sweigart

PO Box 53571

Irvine, CA, 92619

513.404.9354

[Joseph@calwestvisual.com](mailto:Joseph@calwestvisual.com)

EFFECTIVE FROM: March 6, 2019

May 5, 2019

**Customer** Rasul Monoshev

[rMonoshev@magnoliapublicschools.org](mailto:rMonoshev@magnoliapublicschools.org)

CA Small Business Cert# 21611

Magnolia Science Academy

250 E 1st St, Suite 1500

Los Angeles, CA, 90012

213-362-9588

SALESPERSON	JOB	SHIPPING METHOD	SHIPPING TERMS	DELIVERY DATE	DUE DATE
Joe Sweigart	Magnolia Viewsonic	Ground	Ground with liftgate	As scheduled	As scheduled

QTY	ITEM #	DESCRIPTION	UNIT PRICE	LINE TOTAL
20.00	ifp7550	75" Viewsonic Viewboard	2,740.54	\$ 54,810.80
20.00	VB-STND-001	Viewsonic Rolling Trolley Cart	382.00	\$ 7,640.00
20.00	Install	Build rolling cart and install display	250.00	\$ 5,000.00
20.00	IFP-EW-70-02	Viewsonic 4/5 year extended warranty	1.00	\$ 20.00
1.00	PD	1 hour of PD completed by a former teacher	-	\$ -
			Tax 9.5%	5,932.83
			Shipping	-
				73,403.63





CAL WEST VISUALS, INC.

# Quote 486

Joe Sweigart

PO Box 53571

Irvine, CA, 92619

513.404.9354

[Joseph@calwestvisual.com](mailto:Joseph@calwestvisual.com)

EFFECTIVE FROM: March 6, 2019

May 5, 2019

**Customer** Rasul Monoshev

[rMonoshev@magnoliapublicschools.org](mailto:rMonoshev@magnoliapublicschools.org)

CA Small Business Cert# 21611

Magnolia Science Academy

250 E 1st St, Suite 1500

Los Angeles, CA, 90012

213-362-9588

SALESPERSON	JOB	SHIPPING METHOD	SHIPPING TERMS	DELIVERY DATE	DUE DATE
Joe Sweigart	Magnolia Viewsonic	Ground	Ground with liftgate	As scheduled	As scheduled

QTY	ITEM #	DESCRIPTION	UNIT PRICE	LINE TOTAL
6.00	ifp7550	75" Viewsonic Viewboard	2,740.54	\$ 16,443.24
6.00	VB-STND-001	Viewsonic Rolling Trolley Cart	382.00	\$ 2,292.00
6.00	Install	Build rolling cart and install display	250.00	\$ 1,500.00
6.00	IFP-EW-70-02	Viewsonic 4/5 year extended warranty	1.00	\$ 6.00
1.00	PD	1 hour of PD completed by a former teacher	-	\$ -
			Tax 9.5%	1,779.85
			Shipping	-
				22,021.09



CAL WEST VISUALS, INC.

# Quote 487

Joe Sweigart

PO Box 53571

Irvine, CA, 92619

513.404.9354

[Joseph@calwestvisual.com](mailto:Joseph@calwestvisual.com)

EFFECTIVE FROM: March 6, 2019

May 5, 2019

**Customer** Rasul Monoshev

[rMonoshev@magnoliapublicschools.org](mailto:rMonoshev@magnoliapublicschools.org)

CA Small Business Cert# 21611

Magnolia Science Academy

250 E 1st St, Suite 1500

Los Angeles, CA, 90012

213-362-9588

SALESPERSON	JOB	SHIPPING METHOD	SHIPPING TERMS	DELIVERY DATE	DUE DATE
Joe Sweigart	Magnolia Viewsonic	Ground	Ground with liftgate	As scheduled	As scheduled

QTY	ITEM #	DESCRIPTION	UNIT PRICE	LINE TOTAL
6.00	ifp7550	75" Viewsonic Viewboard	2,740.54	\$ 16,443.24
6.00	DWM60100XX	Tripp Lite Display Wall Mount Swivel/Tilt	140.00	\$ 840.00
6.00	Install	Install wall mount and mount display	300.00	\$ 1,800.00
6.00	IFP-EW-70-02	Viewsonic 4/5 year extended warranty	1.00	\$ 6.00
1.00	PD	1 hour of PD completed by a former teacher	-	\$ -
			Tax 9.5%	1,641.91
			Shipping	-
				20,731.15



CAL WEST VISUALS, INC.

# Quote 488

Joe Sweigart

PO Box 53571

Irvine, CA, 92619

513.404.9354

[Joseph@calwestvisual.com](mailto:Joseph@calwestvisual.com)

EFFECTIVE FROM: March 6, 2019

May 5, 2019

**Customer** Rasul Monoshev

[rMonoshev@magnoliapublicschools.org](mailto:rMonoshev@magnoliapublicschools.org)

CA Small Business Cert# 21611

Magnolia Science Academy

250 E 1st St, Suite 1500

Los Angeles, CA, 90012

213-362-9588

SALESPERSON	JOB	SHIPPING METHOD	SHIPPING TERMS	DELIVERY DATE	DUE DATE
Joe Sweigart	Magnolia Viewsonic	Ground	Ground with liftgate	As scheduled	As scheduled

QTY	ITEM #	DESCRIPTION	UNIT PRICE	LINE TOTAL
20.00	ifp7550	75" Viewsonic Viewboard	2,740.54	\$ 54,810.80
20.00	DWM60100XX	Tripp Lite Display Wall Mount Swivel/Tilt	140.00	\$ 2,800.00
20.00	Install	Install wall mount and mount display	300.00	\$ 6,000.00
20.00	IFP-EW-70-02	Viewsonic 4/5 year extended warranty	1.00	\$ 20.00
1.00	PD	1 hour of PD completed by a former teacher	-	\$ -
			Tax 9.5%	5,473.03
			Shipping	-
				69,103.83



CAL WEST VISUALS, INC.

# Quote 542

Joe Sweigart

PO Box 53571

Irvine, CA, 92619

513.404.9354

[Joseph@calwestvisual.com](mailto:Joseph@calwestvisual.com)

EFFECTIVE FROM: March 6, 2019

May 5, 2019

**Customer** Rasul Monoshev

[rMonoshev@magnoliapublicschools.org](mailto:rMonoshev@magnoliapublicschools.org)

CA Small Business Cert# 21611

Magnolia Science Academy

250 E 1st St, Suite 1500

Los Angeles, CA, 90012

213-362-9588

SALESPERSON	JOB	SHIPPING METHOD	SHIPPING TERMS	DELIVERY DATE	DUE DATE
Joe Sweigart	Magnolia Labor	Ground	Ground with liftgate	As scheduled	As scheduled

QTY	ITEM #	DESCRIPTION	UNIT PRICE	LINE TOTAL
1.00	Install	Install wall mount and mount display	300.00	\$ 300.00
1.00	Install	Build rolling cart and install display	250.00	\$ 250.00
		*Pricing for MSA Interactive RFP		
			Tax 9.5%	
			Shipping	-
				550.00



CAL WEST VISUALS, INC.

# Quote 545

Joe Sweigart

PO Box 53571

Irvine, CA, 92619

513.404.9354

[Joseph@calwestvisual.com](mailto:Joseph@calwestvisual.com)

EFFECTIVE FROM: March 6, 2019

May 5, 2019

**Customer** Rasul Monoshev

[rMonoshev@magnoliapublicschools.org](mailto:rMonoshev@magnoliapublicschools.org)

CA Small Business Cert# 21611

Magnolia Science Academy

250 E 1st St, Suite 1500

Los Angeles, CA, 90012

213-362-9588

SALESPERSON	JOB	SHIPPING METHOD	SHIPPING TERMS	DELIVERY DATE	DUE DATE
Joe Sweigart	Magnolia Viewsonic	Ground	Ground with liftgate	As scheduled	As scheduled

QTY	ITEM #	DESCRIPTION	UNIT PRICE	LINE TOTAL
6.00	ifp6560	65" Viewsonic Viewboard inGlass	2,632.22	\$ 15,793.32
6.00	VB-STND-001	Viewsonic Rolling Trolley Cart	382.00	\$ 2,292.00
6.00	Install	Build rolling cart and install display	250.00	\$ 1,500.00
6.00	IFP-EW-60-02	Viewsonic 4/5 year extended warranty	1.00	\$ 6.00
1.00	PD	1 hour of PD completed by a former teacher	-	\$ -
			Tax 9.5%	1,718.11
			Shipping	-
				21,309.43



CAL WEST VISUALS, INC.

# Quote 546

Joe Sweigart

PO Box 53571

Irvine, CA, 92619

513.404.9354

[Joseph@calwestvisual.com](mailto:Joseph@calwestvisual.com)

EFFECTIVE FROM: March 6, 2019

May 5, 2019

**Customer** Rasul Monoshev

[rMonoshev@magnoliapublicschools.org](mailto:rMonoshev@magnoliapublicschools.org)

CA Small Business Cert# 21611

Magnolia Science Academy

250 E 1st St, Suite 1500

Los Angeles, CA, 90012

213-362-9588

SALESPERSON	JOB	SHIPPING METHOD	SHIPPING TERMS	DELIVERY DATE	DUE DATE
Joe Sweigart	Magnolia Viewsonic	Ground	Ground with liftgate	As scheduled	As scheduled

QTY	ITEM #	DESCRIPTION	UNIT PRICE	LINE TOTAL
20.00	ifp6560	65" Viewsonic Viewboard inGlass	2,632.22	\$ 52,644.40
20.00	VB-STND-001	Viewsonic Rolling Trolley Cart	382.00	\$ 7,640.00
20.00	Install	Build rolling cart and install display	250.00	\$ 5,000.00
20.00	IFP-EW-60-02	Viewsonic 4/5 year extended warranty	1.00	\$ 20.00
1.00	PD	1 hour of PD completed by a former teacher	-	\$ -
			Tax 9.5%	5,727.02
			Shipping	-
				71,031.42



CAL WEST VISUALS, INC.

# Quote 547

Joe Sweigart

PO Box 53571

Irvine, CA, 92619

513.404.9354

[Joseph@calwestvisual.com](mailto:Joseph@calwestvisual.com)

EFFECTIVE FROM: March 6, 2019

May 5, 2019

**Customer** Rasul Monoshev

[rMonoshev@magnoliapublicschools.org](mailto:rMonoshev@magnoliapublicschools.org)

CA Small Business Cert# 21611

Magnolia Science Academy

250 E 1st St, Suite 1500

Los Angeles, CA, 90012

213-362-9588

SALESPERSON	JOB	SHIPPING METHOD	SHIPPING TERMS	DELIVERY DATE	DUE DATE
Joe Sweigart	Magnolia Viewsonic	Ground	Ground with liftgate	As scheduled	As scheduled

QTY	ITEM #	DESCRIPTION	UNIT PRICE	LINE TOTAL
20.00	ifp6560	65" Viewsonic Viewboard inGlass	2,632.22	\$ 52,644.40
20.00	Hovermount	Hovermount Flat Panel Mount	410.00	\$ 8,200.00
20.00	Install	Install wall mount and mount display	300.00	\$ 6,000.00
20.00	IFP-EW-60-02	Viewsonic 4/5 year extended warranty	1.00	\$ 20.00
1.00	PD	1 hour of PD completed by a former teacher	-	\$ -
			Tax 9.5%	5,780.22
			Shipping	550.00
				73,194.62



CAL WEST VISUALS, INC.

# Quote 548

Joe Sweigart

PO Box 53571

Irvine, CA, 92619

513.404.9354

[Joseph@calwestvisual.com](mailto:Joseph@calwestvisual.com)

EFFECTIVE FROM: March 6, 2019

May 5, 2019

**Customer** Rasul Monoshev

[rMonoshev@magnoliapublicschools.org](mailto:rMonoshev@magnoliapublicschools.org)

CA Small Business Cert# 21611

Magnolia Science Academy

250 E 1st St, Suite 1500

Los Angeles, CA, 90012

213-362-9588

SALESPERSON	JOB	SHIPPING METHOD	SHIPPING TERMS	DELIVERY DATE	DUE DATE
Joe Sweigart	Magnolia Viewsonic	Ground	Ground with liftgate	As scheduled	As scheduled

QTY	ITEM #	DESCRIPTION	UNIT PRICE	LINE TOTAL
6.00	ifp6560	65" Viewsonic Viewboard inGlass	2,632.22	\$ 15,793.32
6.00	Hovermount	Hovermount Flat Panel Mount	410.00	\$ 2,460.00
6.00	Install	Install wall mount and mount display	300.00	\$ 1,800.00
6.00	IFP-EW-60-02	Viewsonic 4/5 year extended warranty	1.00	\$ 6.00
1.00	PD	1 hour of PD completed by a former teacher	-	\$ -
			Tax 9.5%	1,734.07
			Shipping	200.00
				21,993.39





VIA EMAIL

March 4, 2019

Cal West Visuals, Inc.  
23 Agave  
Lake Forest, CA 92630  
Attn: Joseph Sweigart  
Email: joseph@calwestvisual.com

Subject: Letter of Authorization

ViewSonic Corporation ("ViewSonic") is a worldwide provider of Visual Display Technology™ products under the brand name of ViewSonic®. ViewSonic does not have a reseller authorization program, as its products are generally available through distribution on the open market to all resellers.

This letter is to confirm that Cal West Visuals, Inc. ("Reseller") is an authorized ViewSonic reseller under ViewSonic's Finch Club<sup>SM</sup> Reseller Partner Program. In order to become a member of this program, the reseller must submit documentation demonstrating to ViewSonic's satisfaction that they are licensed to conduct business in a particular state or province and maintain good financial and partnership standings. The contract between the parties entitles Reseller access to special programs, pricing and benefits, including marketing, technical and warranty support offered by ViewSonic.

By providing this letter, ViewSonic does not intend to be legally bound by the terms and conditions of any Request for Proposal, Request for Quotation, Contract, or any other legally binding document.

Any questions relating to ViewSonic's products should be directed to your ViewSonic Sales Representative.

Sincerely,

Sung Yi  
CFO



February 25, 2019

Alpha Solutions  
14320 Ventura Blvd., Suite 507  
Sherman Oaks, CA 91423  
Attn: Loren Greenshields  
Email: Loren@alphaav.com

Subject: Letter of Authorization

ViewSonic Corporation ("ViewSonic") is a worldwide provider of Visual Display Technology™ products under the brand name of ViewSonic®. ViewSonic does not have a reseller authorization program, as its products are generally available through distribution on the open market to all resellers.

This letter is to confirm that Alpha Solutions ("Reseller") is an authorized ViewSonic reseller under ViewSonic's Finch Club<sup>SM</sup> Reseller Partner Program. In order to become a member of this program, the reseller must submit documentation demonstrating to ViewSonic's satisfaction that they are licensed to conduct business in a particular state or province and maintain good financial and partnership standings. The contract between the parties entitles Reseller access to special programs, pricing and benefits, including marketing, technical and warranty support offered by ViewSonic.

By providing this letter, ViewSonic does not intend to be legally bound by the terms and conditions of any Request for Proposal, Request for Quotation, Contract, or any other legally binding document.

Any questions relating to ViewSonic's products should be directed to Lacey Patnella at Lacey.Patnella@viewsonic.com.

Sincerely,

Sung Yi  
CFO



Alpha Solutions, Inc.  
 Tel: 949-415-2000  
 info@alphaav.com  
 http://www.alphaav.com

Magnolia Public Schools  
 250 E. 1st Street  
 Los Angeles CA 90012

## Quotation # SO833

### 75" and 65" Viewsonic cart Install only

Quotation Date:  
 03/06/2019 23:20:16

Salesperson:  
 Loren Greenshields

Expiration Date:  
 04/05/2019

DESCRIPTION	QUANTITY	UNIT PRICE	TAXES	AMOUNT
*Install - Assemble and test Mobile trolley cart. Attach 65" or 75" ViewSonic to mount and adjust. Test and calibrate. (Two techs required due to size and weight) Alpha Solutions is C7 licensed and only uses our in house certified installers. COI by request.	1.000	200.00		\$ 200.00
<b>Subtotal</b>				\$ 200.00
<b>Total</b>				\$ 200.00



Alpha Solutions, Inc.  
Tel: 949-415-2000  
info@alphaav.com  
http://www.alphaav.com

The above prices, specifications, and conditions are satisfactory and are hereby accepted. Alpha is authorized to do the work as specified. The signature on this contract is evidence of acceptance of all terms and conditions within.

Signature: \_\_\_\_\_ Date: \_\_\_\_\_

**To Order:**

For existing customers, please submit a copy of the approved quotation along with a PO and/or deposit/payment (check or credit card authorization), in accordance with your pre-set credit terms, to SALES@alphaav.com . For new customers, please contact your Sales Representative to discuss payment options, or to setup credit terms.

**Return Policy:**

Product must be returned within 30 days of invoice date and be in new factory fresh condition along with original packaging. Restocking fees and freight charges will apply. These prices may not include applicable taxes, insurance, shipping, delivery, setup fees, or any cables or cabling services or material unless specifically listed above.

**Additional Terms and Conditions:**

By accepting this quote, you agree to the Terms and Conditions below. Past due invoices are subject to a 1.5% monthly interest charge.

**TERMS AND CONDITIONS FOR SALE OF GOODS:**

1. Quote. These terms and conditions are deemed incorporated into the attached quote for goods and/or services ("Quote"). This Quote will remain open for thirty (30) days. Upon buyer's acceptance of the Quote, whether verbally or in writing, buyer will become bound to the Quote and the terms and conditions set forth herein. In the event that buyer submits a purchase order with additional terms and conditions, then buyer's additional terms and conditions shall not become part of the agreement between the parties unless Alpha Solutions Inc. ("Seller") acknowledges receipt of such in writing and the parties each sign an amendment to this agreement.
2. Goods. Seller agrees to sell and buyer agrees to buy the goods described in the Quote or which comply with buyer's written specifications ("Goods").
3. Payment. Buyer will promptly pay all sums upon tender of delivery, but in no event later than thirty (30) days after the invoice date. All late payments shall incur a service charge in the amount of one and a half percent (1.5%) per month and a late fee equivalent to one and a half percent (1.5%) of the total amount invoiced. Any deviation from quoted specifications requested by buyer will require management approval which will be provided in writing upon approval.
4. Shipping. Goods are sold F.O.B. destination, title and risk remain with Seller until goods are delivered to the location specified in the contract.
5. Taxes. Prices are subject to all federal, state and local excise, sales, use and similar taxes, if any.
6. Delivery. The delivery of Goods will be made, in single or multiple lots, as specified herein and will be made on or before the date specified herein, or within a reasonable time thereafter. The delivery schedule hereof shall be considered extended by a period of time equal to the time lost because of any delay, which is due to causes beyond Seller's reasonable control. All installments will be separately invoiced and paid as billed without regard to future deliveries. Failure to pay for any installment when due shall excuse Seller from making further deliveries. Delay in delivery of any installment shall not relieve buyer of its obligation to accept remaining installments. All claims for delay shall be deemed waived, unless presented to Seller in writing within ten (10) days after delivery of each shipment. The Goods shall be delivered to the place identified in the Quote.



Alpha Solutions, Inc.  
Tel: 949-415-2000  
info@alphaav.com  
<http://www.alphaav.com>

7. Shipment Under Reservation. Seller will maintain title and the right of possession in the Goods sold until payment thereof is made by buyer.
8. Packaging. Seller/Manufacturer will determine the type of container and arrange for suitable packaging for domestic transport and delivery of the Goods, and charges related thereto are included in the price for the Goods set forth herein and will be paid by Seller.
9. Warranty. Standard manufacturer warranties apply on all applicable products. For a period of ninety (90) days after delivery, the services will be free from defects in material and workmanship under normal use as intended. Seller's sole liability under the foregoing warranty, at Seller's sole election, is limited to replacement of Goods, repair of defects, or refund of the purchase price. Service and maintenance agreements can be included as an additional contract to any quote, but must be done in writing.
10. DISCLAIMER AND LIMITATION OF LIABILITY. EXCEPT AS SET FORTH ABOVE, SELLER MAKES NO WARRANTIES OF ANY KIND EITHER EXPRESS OR IMPLIED REGARDING THE GOODS. SELLER EXPRESSLY DISCLAIMS ANY IMPLIED WARRANTIES OF MERCHANTABILITY OR FITNESS FOR ANY PARTICULAR PURPOSE. IN RECOGNITION OF THE RELATIVE RISKS AND BENEFITS OF THIS AGREEMENT TO THE PARTIES, BUYER AGREES TO LIMIT SELLER'S TOTAL LIABILITY TO BUYER AND ANY OTHER THIRD PARTY FROM AND AGAINST ANY AND ALL CLAIMS, LOSSES, DAMAGES, LIABILITIES, COSTS, EXPENSES, JUDGMENTS, OR OBLIGATIONS WHATSOEVER, INCLUDING, BUT NOT LIMITED TO, REASONABLE ATTORNEYS' AND EXPERTS' FEES AND COSTS, FROM ANY CAUSE OR CAUSES, SUCH THAT SELLER'S TOTAL LIABILITY TO THOSE NAMED ABOVE SHALL NOT EXCEED THE TOTAL COMPENSATION PAID TO SELLER UNDER THIS AGREEMENT. THIS LIMITATION OF LIABILITY INCLUDES, BUT IS NOT LIMITED TO, ALLEGATIONS OR PROOF OF NEGLIGENCE, INDEMNITY, BREACH OF CONTRACT, STRICT LIABILITY, OR WARRANTY OR ANY OTHER CONTRACT OR TORT CLAIM PLEAD. SELLER SHALL NOT BE LIABLE, AND BUYER HEREBY WAIVES ANY AND ALL CLAIMS, FOR CONSEQUENTIAL DAMAGES, INCIDENTAL DAMAGES, ECONOMIC LOSS DAMAGES, and PUNITIVE DAMAGES (INCLUDING, WITHOUT LIMITATION, LOST PROFITS, DOWNTIME, LOST SAVINGS, COST OF PROCESSING, INJURY TO GOODWILL, REPRODUCTION COSTS, ETC) RELATING IN ANYWAY TO THIS AGREEMENT.
12. Risk of Loss. The risk of loss of the Goods shall pass to buyer as soon as the Goods are tendered to buyer. In the event the Goods are destroyed or damaged, in whole or in part, prior to the time the risk of loss passes to buyer, this agreement shall be voided and buyer excused from all obligations hereunder. If the loss is partial, buyer shall have the right to accept that portion of the Goods which conform to the agreement.
13. Rejected Goods. In the event buyer rejects any shipment of the Goods, and elects to accept only a part thereof, it is agreed that the portion of Goods rejected shall be returned to Seller within thirty (30) days of the invoice date and shall be at the expense and risk of buyer. Seller shall have the right in its discretion either to replace the rejected Goods or to refund the purchase price applicable thereto. All returns shall be subject to a re-stocking fee of twenty five percent (25%) of the purchased price of the products being returned and freight charges will apply.
14. Termination. Seller may, in its sole discretion, terminate this agreement and/or refuse to make any further deliveries, if buyer (i) fails to comply with any of these terms and conditions, (ii) becomes insolvent, (iii) violates any law, regulation or ordinance which may govern the sale, handling or disposition of any of the Custom Goods, (iv) makes any assignment for the benefit of creditors, or (v) is adjudged bankrupt.
15. Buyer's Remedies. In the event of a breach of this agreement by Seller, buyer's right to damages shall be limited to the difference between the contract and the market price of the Goods, and buyer shall not have the right to "cover" and fix damages by contracting for substitute Goods.
16. Assignment. Neither party may assign this agreement without the prior written consent of the other party.



Alpha Solutions, Inc.  
Tel: 949-415-2000  
info@alphaav.com  
<http://www.alphaav.com>

17. Force Majeure. Seller shall not be responsible for delays in delivery or any failure to deliver due to causes beyond Seller's reasonable control including, but not limited to, acts of God, war, mobilization, civil commissions, riots, embargoes, domestic or foreign governmental regulations or orders, fires, floods, strikes, lockouts and other labor difficulties, or shortages of or inability to obtain shipping space or transportation.

18. Choice of Law; Venue. This agreement and all of the rights and obligations of the parties hereto, are governed by the laws of the State of California. The parties agree that any and all lawsuits shall be filed in the County of Los Angeles. All disputes shall be submitted to non binding mediation prior to the filing of any lawsuit.

19. Authority. Buyer represents and warrants that (i) it has the full right, power, and authority to enter into this agreement and perform all of the obligations herein, and (ii) the person signing on behalf of buyer has the complete power and authority to bind the buyer to this agreement.

20. Entire Agreement. Once accepted, these terms and conditions, along with the Quote, constitute the entire agreement between buyer and Seller with respect to the Goods and may not be modified except by a writing signed by both parties.



Alpha Solutions, Inc.  
Tel: 949-415-2000  
info@alphaav.com  
http://www.alphaav.com

Magnolia Public Schools  
250 E. 1st Street  
Los Angeles CA 90012

## Quotation # SO832 75" and 65" Viewsonic Install only

Quotation Date:  
03/06/2019 23:01:01

Salesperson:  
Loren Greenshields

Expiration Date:  
04/05/2019

DESCRIPTION	QUANTITY	UNIT PRICE	TAXES	AMOUNT
*Install - Install WMK-047-2 on flat drywall, must have two(2) wood/metal studs available at 16" on center. Attach 75" or 65" ViewSonic to mount and adjust. Test and calibrate. (Two techs required due to size and weight) Alpha Solutions is C7 licensed and only uses our in house certified installers. COI by request.	1.000	225.00		\$ 225.00
<b>Subtotal</b>				\$ 225.00
<b>Total</b>				\$ 225.00



Alpha Solutions, Inc.  
Tel: 949-415-2000  
info@alphaav.com  
http://www.alphaav.com

The above prices, specifications, and conditions are satisfactory and are hereby accepted. Alpha is authorized to do the work as specified. The signature on this contract is evidence of acceptance of all terms and conditions within.

Signature: \_\_\_\_\_ Date: \_\_\_\_\_

**To Order:**

For existing customers, please submit a copy of the approved quotation along with a PO and/or deposit/payment (check or credit card authorization), in accordance with your pre-set credit terms, to SALES@alphaav.com . For new customers, please contact your Sales Representative to discuss payment options, or to setup credit terms.

**Return Policy:**

Product must be returned within 30 days of invoice date and be in new factory fresh condition along with original packaging. Restocking fees and freight charges will apply. These prices may not include applicable taxes, insurance, shipping, delivery, setup fees, or any cables or cabling services or material unless specifically listed above.

**Additional Terms and Conditions:**

By accepting this quote, you agree to the Terms and Conditions below. Past due invoices are subject to a 1.5% monthly interest charge.

**TERMS AND CONDITIONS FOR SALE OF GOODS:**

1. Quote. These terms and conditions are deemed incorporated into the attached quote for goods and/or services ("Quote"). This Quote will remain open for thirty (30) days. Upon buyer's acceptance of the Quote, whether verbally or in writing, buyer will become bound to the Quote and the terms and conditions set forth herein. In the event that buyer submits a purchase order with additional terms and conditions, then buyer's additional terms and conditions shall not become part of the agreement between the parties unless Alpha Solutions Inc. ("Seller") acknowledges receipt of such in writing and the parties each sign an amendment to this agreement.
2. Goods. Seller agrees to sell and buyer agrees to buy the goods described in the Quote or which comply with buyer's written specifications ("Goods").
3. Payment. Buyer will promptly pay all sums upon tender of delivery, but in no event later than thirty (30) days after the invoice date. All late payments shall incur a service charge in the amount of one and a half percent (1.5%) per month and a late fee equivalent to one and a half percent (1.5%) of the total amount invoiced. Any deviation from quoted specifications requested by buyer will require management approval which will be provided in writing upon approval.
4. Shipping. Goods are sold F.O.B. destination, title and risk remain with Seller until goods are delivered to the location specified in the contract.
5. Taxes. Prices are subject to all federal, state and local excise, sales, use and similar taxes, if any.
6. Delivery. The delivery of Goods will be made, in single or multiple lots, as specified herein and will be made on or before the date specified herein, or within a reasonable time thereafter. The delivery schedule hereof shall be considered extended by a period of time equal to the time lost because of any delay, which is due to causes beyond Seller's reasonable control. All installments will be separately invoiced and paid as billed without regard to future deliveries. Failure to pay for any installment when due shall excuse Seller from making further deliveries. Delay in delivery of any installment shall not relieve buyer of its obligation to accept remaining installments. All claims for delay shall be deemed waived, unless presented to Seller in writing within ten (10) days after delivery of each shipment. The Goods shall be delivered to the place identified in the Quote.





7. Shipment Under Reservation. Seller will maintain title and the right of possession in the Goods sold until payment thereof is made by buyer.
8. Packaging. Seller/Manufacturer will determine the type of container and arrange for suitable packaging for domestic transport and delivery of the Goods, and charges related thereto are included in the price for the Goods set forth herein and will be paid by Seller.
9. Warranty. Standard manufacturer warranties apply on all applicable products. For a period of ninety (90) days after delivery, the services will be free from defects in material and workmanship under normal use as intended. Seller's sole liability under the foregoing warranty, at Seller's sole election, is limited to replacement of Goods, repair of defects, or refund of the purchase price. Service and maintenance agreements can be included as an additional contract to any quote, but must be done in writing.
10. DISCLAIMER AND LIMITATION OF LIABILITY. EXCEPT AS SET FORTH ABOVE, SELLER MAKES NO WARRANTIES OF ANY KIND EITHER EXPRESS OR IMPLIED REGARDING THE GOODS. SELLER EXPRESSLY DISCLAIMS ANY IMPLIED WARRANTIES OF MERCHANTABILITY OR FITNESS FOR ANY PARTICULAR PURPOSE. IN RECOGNITION OF THE RELATIVE RISKS AND BENEFITS OF THIS AGREEMENT TO THE PARTIES, BUYER AGREES TO LIMIT SELLER'S TOTAL LIABILITY TO BUYER AND ANY OTHER THIRD PARTY FROM AND AGAINST ANY AND ALL CLAIMS, LOSSES, DAMAGES, LIABILITIES, COSTS, EXPENSES, JUDGMENTS, OR OBLIGATIONS WHATSOEVER, INCLUDING, BUT NOT LIMITED TO, REASONABLE ATTORNEYS' AND EXPERTS' FEES AND COSTS, FROM ANY CAUSE OR CAUSES, SUCH THAT SELLER'S TOTAL LIABILITY TO THOSE NAMED ABOVE SHALL NOT EXCEED THE TOTAL COMPENSATION PAID TO SELLER UNDER THIS AGREEMENT. THIS LIMITATION OF LIABILITY INCLUDES, BUT IS NOT LIMITED TO, ALLEGATIONS OR PROOF OF NEGLIGENCE, INDEMNITY, BREACH OF CONTRACT, STRICT LIABILITY, OR WARRANTY OR ANY OTHER CONTRACT OR TORT CLAIM PLEAD. SELLER SHALL NOT BE LIABLE, AND BUYER HEREBY WAIVES ANY AND ALL CLAIMS, FOR CONSEQUENTIAL DAMAGES, INCIDENTAL DAMAGES, ECONOMIC LOSS DAMAGES, and PUNITIVE DAMAGES (INCLUDING, WITHOUT LIMITATION, LOST PROFITS, DOWNTIME, LOST SAVINGS, COST OF PROCESSING, INJURY TO GOODWILL, REPRODUCTION COSTS, ETC) RELATING IN ANYWAY TO THIS AGREEMENT.
12. Risk of Loss. The risk of loss of the Goods shall pass to buyer as soon as the Goods are tendered to buyer. In the event the Goods are destroyed or damaged, in whole or in part, prior to the time the risk of loss passes to buyer, this agreement shall be voided and buyer excused from all obligations hereunder. If the loss is partial, buyer shall have the right to accept that portion of the Goods which conform to the agreement.
13. Rejected Goods. In the event buyer rejects any shipment of the Goods, and elects to accept only a part thereof, it is agreed that the portion of Goods rejected shall be returned to Seller within thirty (30) days of the invoice date and shall be at the expense and risk of buyer. Seller shall have the right in its discretion either to replace the rejected Goods or to refund the purchase price applicable thereto. All returns shall be subject to a re-stocking fee of twenty five percent (25%) of the purchased price of the products being returned and freight charges will apply.
14. Termination. Seller may, in its sole discretion, terminate this agreement and/or refuse to make any further deliveries, if buyer (i) fails to comply with any of these terms and conditions, (ii) becomes insolvent, (iii) violates any law, regulation or ordinance which may govern the sale, handling or disposition of any of the Custom Goods, (iv) makes any assignment for the benefit of creditors, or (v) is adjudged bankrupt.
15. Buyer's Remedies. In the event of a breach of this agreement by Seller, buyer's right to damages shall be limited to the difference between the contract and the market price of the Goods, and buyer shall not have the right to "cover" and fix damages by contracting for substitute Goods.
16. Assignment. Neither party may assign this agreement without the prior written consent of the other party.



Alpha Solutions, Inc.  
Tel: 949-415-2000  
info@alphaav.com  
<http://www.alphaav.com>

17. Force Majeure. Seller shall not be responsible for delays in delivery or any failure to deliver due to causes beyond Seller's reasonable control including, but not limited to, acts of God, war, mobilization, civil commissions, riots, embargoes, domestic or foreign governmental regulations or orders, fires, floods, strikes, lockouts and other labor difficulties, or shortages of or inability to obtain shipping space or transportation.

18. Choice of Law; Venue. This agreement and all of the rights and obligations of the parties hereto, are governed by the laws of the State of California. The parties agree that any and all lawsuits shall be filed in the County of Los Angeles. All disputes shall be submitted to non binding mediation prior to the filing of any lawsuit.

19. Authority. Buyer represents and warrants that (i) it has the full right, power, and authority to enter into this agreement and perform all of the obligations herein, and (ii) the person signing on behalf of buyer has the complete power and authority to bind the buyer to this agreement.

20. Entire Agreement. Once accepted, these terms and conditions, along with the Quote, constitute the entire agreement between buyer and Seller with respect to the Goods and may not be modified except by a writing signed by both parties.



Alpha Solutions, Inc.  
 Tel: 949-415-2000  
 info@alphaav.com  
 http://www.alphaav.com

Magnolia Public Schools  
 250 E. 1st Street  
 Los Angeles CA 90012

# Quotation # SO758

## MSA1 65" Viewsonic with Hovermount

Quotation Date: 02/06/2019 01:57:50      Salesperson: Loren Greenshields      Expiration Date: 03/08/2019

DESCRIPTION	QUANTITY	UNIT PRICE	TAXES	AMOUNT
[IFP6550] ViewSonic 65" ViewBoard Viewsonic 65" Viewboard	20.000	2,028.00	Sales Tax	\$ 40,560.00
[IFP-EW-65-02] IFP-EW-65-02 VIEWSONIC : 65- 75 inch Interactive Display Extended On-Site Repair Warranty for 4th and 5th Year INCLUDED IN BOARD PRICE	20.000	0.00	Sales Tax	\$ 0.00
[Hovermount] Hovermount Flat Panel Mount, height adjustable up to 125lbs	20.000	430.00		\$ 8,600.00
[LB-WIFI-001] LB-WIFI-001 Wifi card INCLUDED IN BOARD PRICE	20.000	0.00	Sales Tax	\$ 0.00
ViewSonic training - 1 hour INCLUDED	1.000	0.00	Sales Tax	\$ 0.00
Shipping - Free shipping for ViewSonic	1.000	0.00	Sales Tax	\$ 0.00

<b>Subtotal</b>	\$ 49,160.00
<b>Taxes</b>	\$ 3,853.20
<b>Total</b>	\$ 53,013.20



Alpha Solutions, Inc.  
Tel: 949-415-2000  
info@alphaav.com  
<http://www.alphaav.com>



Alpha Solutions, Inc.  
Tel: 949-415-2000  
info@alphaav.com  
http://www.alphaav.com

The above prices, specifications, and conditions are satisfactory and are hereby accepted. Alpha is authorized to do the work as specified. The signature on this contract is evidence of acceptance of all terms and conditions within.

Signature: \_\_\_\_\_ Date: \_\_\_\_\_

**To Order:**

For existing customers, please submit a copy of the approved quotation along with a PO and/or deposit/payment (check or credit card authorization), in accordance with your pre-set credit terms, to SALES@alphaav.com . For new customers, please contact your Sales Representative to discuss payment options, or to setup credit terms.

**Return Policy:**

Product must be returned within 30 days of invoice date and be in new factory fresh condition along with original packaging. Restocking fees and freight charges will apply. These prices may not include applicable taxes, insurance, shipping, delivery, setup fees, or any cables or cabling services or material unless specifically listed above.

**Additional Terms and Conditions:**

By accepting this quote, you agree to the Terms and Conditions below. Past due invoices are subject to a 1.5% monthly interest charge.

**TERMS AND CONDITIONS FOR SALE OF GOODS:**

1. **Quote.** These terms and conditions are deemed incorporated into the attached quote for goods and/or services ("Quote"). This Quote will remain open for thirty (30) days. Upon buyer's acceptance of the Quote, whether verbally or in writing, buyer will become bound to the Quote and the terms and conditions set forth herein. In the event that buyer submits a purchase order with additional terms and conditions, then buyer's additional terms and conditions shall not become part of the agreement between the parties unless Alpha Solutions Inc. ("Seller") acknowledges receipt of such in writing and the parties each sign an amendment to this agreement.
2. **Goods.** Seller agrees to sell and buyer agrees to buy the goods described in the Quote or which comply with buyer's written specifications ("Goods").
3. **Payment.** Buyer will promptly pay all sums upon tender of delivery, but in no event later than thirty (30) days after the invoice date. All late payments shall incur a service charge in the amount of one and a half percent (1.5%) per month and a late fee equivalent to one and a half percent (1.5%) of the total amount invoiced. Any deviation from quoted specifications requested by buyer will require management approval which will be provided in writing upon approval.
4. **Shipping.** Goods are sold F.O.B. destination, title and risk remain with Seller until goods are delivered to the location specified in the contract.
5. **Taxes.** Prices are subject to all federal, state and local excise, sales, use and similar taxes, if any.
6. **Delivery.** The delivery of Goods will be made, in single or multiple lots, as specified herein and will be made on or before the date specified herein, or within a reasonable time thereafter. The delivery schedule hereof shall be considered extended by a period of time equal to the time lost because of any delay, which is due to causes beyond Seller's reasonable control. All installments will be separately invoiced and paid as billed without regard to future deliveries. Failure to pay for any installment when due shall excuse Seller from making further deliveries. Delay in delivery of any installment shall not relieve buyer of its obligation to accept remaining installments. All claims for delay shall be deemed waived, unless presented to Seller in writing within ten (10) days after delivery of each shipment. The Goods shall be delivered to the place identified in the Quote.



Alpha Solutions, Inc.  
Tel: 949-415-2000  
info@alphaav.com  
<http://www.alphaav.com>

7. Shipment Under Reservation. Seller will maintain title and the right of possession in the Goods sold until payment thereof is made by buyer.

8. Packaging. Seller/Manufacturer will determine the type of container and arrange for suitable packaging for domestic transport and delivery of the Goods, and charges related thereto are included in the price for the Goods set forth herein and will be paid by Seller.

9. Warranty. Standard manufacturer warranties apply on all applicable products. For a period of ninety (90) days after delivery, the services will be free from defects in material and workmanship under normal use as intended. Seller's sole liability under the foregoing warranty, at Seller's sole election, is limited to replacement of Goods, repair of defects, or refund of the purchase price. Service and maintenance agreements can be included as an additional contract to any quote, but must be done in writing.

10. DISCLAIMER AND LIMITATION OF LIABILITY. EXCEPT AS SET FORTH ABOVE, SELLER MAKES NO WARRANTIES OF ANY KIND EITHER EXPRESS OR IMPLIED REGARDING THE GOODS. SELLER EXPRESSLY DISCLAIMS ANY IMPLIED WARRANTIES OF MERCHANTABILITY OR FITNESS FOR ANY PARTICULAR PURPOSE. IN RECOGNITION OF THE RELATIVE RISKS AND BENEFITS OF THIS AGREEMENT TO THE PARTIES, BUYER AGREES TO LIMIT SELLER'S TOTAL LIABILITY TO BUYER AND ANY OTHER THIRD PARTY FROM AND AGAINST ANY AND ALL CLAIMS, LOSSES, DAMAGES, LIABILITIES, COSTS, EXPENSES, JUDGMENTS, OR OBLIGATIONS WHATSOEVER, INCLUDING, BUT NOT LIMITED TO, REASONABLE ATTORNEYS' AND EXPERTS' FEES AND COSTS, FROM ANY CAUSE OR CAUSES, SUCH THAT SELLER'S TOTAL LIABILITY TO THOSE NAMED ABOVE SHALL NOT EXCEED THE TOTAL COMPENSATION PAID TO SELLER UNDER THIS AGREEMENT. THIS LIMITATION OF LIABILITY INCLUDES, BUT IS NOT LIMITED TO, ALLEGATIONS OR PROOF OF NEGLIGENCE, INDEMNITY, BREACH OF CONTRACT, STRICT LIABILITY, OR WARRANTY OR ANY OTHER CONTRACT OR TORT CLAIM PLEAD. SELLER SHALL NOT BE LIABLE, AND BUYER HEREBY WAIVES ANY AND ALL CLAIMS, FOR CONSEQUENTIAL DAMAGES, INCIDENTAL DAMAGES, ECONOMIC LOSS DAMAGES, and PUNITIVE DAMAGES (INCLUDING, WITHOUT LIMITATION, LOST PROFITS, DOWNTIME, LOST SAVINGS, COST OF PROCESSING, INJURY TO GOODWILL, REPRODUCTION COSTS, ETC) RELATING IN ANYWAY TO THIS AGREEMENT.

12. Risk of Loss. The risk of loss of the Goods shall pass to buyer as soon as the Goods are tendered to buyer. In the event the Goods are destroyed or damaged, in whole or in part, prior to the time the risk of loss passes to buyer, this agreement shall be voided and buyer excused from all obligations hereunder. If the loss is partial, buyer shall have the right to accept that portion of the Goods which conform to the agreement.

13. Rejected Goods. In the event buyer rejects any shipment of the Goods, and elects to accept only a part thereof, it is agreed that the portion of Goods rejected shall be returned to Seller within thirty (30) days of the invoice date and shall be at the expense and risk of buyer. Seller shall have the right in its discretion either to replace the rejected Goods or to refund the purchase price applicable thereto. All returns shall be subject to a re-stocking fee of twenty five percent (25%) of the purchased price of the products being returned and freight charges will apply.

14. Termination. Seller may, in its sole discretion, terminate this agreement and/or refuse to make any further deliveries, if buyer (i) fails to comply with any of these terms and conditions, (ii) becomes insolvent, (iii) violates any law, regulation or ordinance which may govern the sale, handling or disposition of any of the Custom Goods, (iv) makes any assignment for the benefit of creditors, or (v) is adjudged bankrupt.

15. Buyer's Remedies. In the event of a breach of this agreement by Seller, buyer's right to damages shall be limited to the difference between the contract and the market price of the Goods, and buyer shall not have the right to "cover" and fix damages by contracting for substitute Goods.

16. Assignment. Neither party may assign this agreement without the prior written consent of the other party.



Alpha Solutions, Inc.  
Tel: 949-415-2000  
info@alphaav.com  
<http://www.alphaav.com>

17. Force Majeure. Seller shall not be responsible for delays in delivery or any failure to deliver due to causes beyond Seller's reasonable control including, but not limited to, acts of God, war, mobilization, civil commissions, riots, embargoes, domestic or foreign governmental regulations or orders, fires, floods, strikes, lockouts and other labor difficulties, or shortages of or inability to obtain shipping space or transportation.

18. Choice of Law; Venue. This agreement and all of the rights and obligations of the parties hereto, are governed by the laws of the State of California. The parties agree that any and all lawsuits shall be filed in the County of Los Angeles. All disputes shall be submitted to non binding mediation prior to the filing of any lawsuit.

19. Authority. Buyer represents and warrants that (i) it has the full right, power, and authority to enter into this agreement and perform all of the obligations herein, and (ii) the person signing on behalf of buyer has the complete power and authority to bind the buyer to this agreement.

20. Entire Agreement. Once accepted, these terms and conditions, along with the Quote, constitute the entire agreement between buyer and Seller with respect to the Goods and may not be modified except by a writing signed by both parties.



Alpha Solutions, Inc.  
 Tel: 949-415-2000  
 info@alphaav.com  
 http://www.alphaav.com

Magnolia Public Schools  
 250 E. 1st Street  
 Los Angeles CA 90012

# Quotation # SO760

## MAS1 65" Viewsonic with rolling cart

Quotation Date:  
02/06/2019 02:03:38

Salesperson:  
Loren Greenshields

Expiration Date:  
03/08/2019

DESCRIPTION	QUANTITY	UNIT PRICE	TAXES	AMOUNT
[IFP6550] ViewSonic 65" ViewBoard Viewsonic 65" Viewboard	20.000	2,028.00	Sales Tax	\$ 40,560.00
[IFP-EW-65-02] IFP-EW-65-02 VIEWSONIC : 65- 70inch Interactive Display Extended On-Site Repair Warranty for 4th and 5th Year INCLUDED IN BOARD PRICE	20.000	0.00	Sales Tax	\$ 0.00
[LB-WIFI-001] LB-WIFI-001 Wifi card INCLUDED IN BOARD PRICE	20.000	0.00	Sales Tax	\$ 0.00
[VB-STND-001 ] VB-STND-001 Mobile Trolley Cart, ADA compliant for ViewBoard interactive flat panel displays.	20.000	388.00	Sales Tax	\$ 7,760.00
MAGNOLIA PUBLIC SCHOOLS ONLY				
ViewSonic training - 1 hour INCLUDED	1.000	0.00	Sales Tax	\$ 0.00
Shipping - Free shipping for all ViewSonic products	1.000	0.00	Sales Tax	\$ 0.00
<b>Subtotal</b>				\$ 48,320.00
Taxes on \$ 48,320.00				\$ 4,590.40





Alpha Solutions, Inc.  
Tel: 949-415-2000  
info@alphaav.com  
<http://www.alphaav.com>

---

Total \$ 52,910.40

---



Alpha Solutions, Inc.  
Tel: 949-415-2000  
info@alphaav.com  
http://www.alphaav.com

The above prices, specifications, and conditions are satisfactory and are hereby accepted. Alpha is authorized to do the work as specified. The signature on this contract is evidence of acceptance of all terms and conditions within.

Signature: \_\_\_\_\_ Date: \_\_\_\_\_

**To Order:**

For existing customers, please submit a copy of the approved quotation along with a PO and/or deposit/payment (check or credit card authorization), in accordance with your pre-set credit terms, to SALES@alphaav.com . For new customers, please contact your Sales Representative to discuss payment options, or to setup credit terms.

**Return Policy:**

Product must be returned within 30 days of invoice date and be in new factory fresh condition along with original packaging. Restocking fees and freight charges will apply. These prices may not include applicable taxes, insurance, shipping, delivery, setup fees, or any cables or cabling services or material unless specifically listed above.

**Additional Terms and Conditions:**

By accepting this quote, you agree to the Terms and Conditions below. Past due invoices are subject to a 1.5% monthly interest charge.

**TERMS AND CONDITIONS FOR SALE OF GOODS:**

1. **Quote.** These terms and conditions are deemed incorporated into the attached quote for goods and/or services ("Quote"). This Quote will remain open for thirty (30) days. Upon buyer's acceptance of the Quote, whether verbally or in writing, buyer will become bound to the Quote and the terms and conditions set forth herein. In the event that buyer submits a purchase order with additional terms and conditions, then buyer's additional terms and conditions shall not become part of the agreement between the parties unless Alpha Solutions Inc. ("Seller") acknowledges receipt of such in writing and the parties each sign an amendment to this agreement.
2. **Goods.** Seller agrees to sell and buyer agrees to buy the goods described in the Quote or which comply with buyer's written specifications ("Goods").
3. **Payment.** Buyer will promptly pay all sums upon tender of delivery, but in no event later than thirty (30) days after the invoice date. All late payments shall incur a service charge in the amount of one and a half percent (1.5%) per month and a late fee equivalent to one and a half percent (1.5%) of the total amount invoiced. Any deviation from quoted specifications requested by buyer will require management approval which will be provided in writing upon approval.
4. **Shipping.** Goods are sold F.O.B. destination, title and risk remain with Seller until goods are delivered to the location specified in the contract.
5. **Taxes.** Prices are subject to all federal, state and local excise, sales, use and similar taxes, if any.
6. **Delivery.** The delivery of Goods will be made, in single or multiple lots, as specified herein and will be made on or before the date specified herein, or within a reasonable time thereafter. The delivery schedule hereof shall be considered extended by a period of time equal to the time lost because of any delay, which is due to causes beyond Seller's reasonable control. All installments will be separately invoiced and paid as billed without regard to future deliveries. Failure to pay for any installment when due shall excuse Seller from making further deliveries. Delay in delivery of any installment shall not relieve buyer of its obligation to accept remaining installments. All claims for delay shall be deemed waived, unless presented to Seller in writing within ten (10) days after delivery of each shipment. The Goods shall be delivered to the place identified in the Quote.



Alpha Solutions, Inc.  
Tel: 949-415-2000  
info@alphaav.com  
<http://www.alphaav.com>

7. Shipment Under Reservation. Seller will maintain title and the right of possession in the Goods sold until payment thereof is made by buyer.

8. Packaging. Seller/Manufacturer will determine the type of container and arrange for suitable packaging for domestic transport and delivery of the Goods, and charges related thereto are included in the price for the Goods set forth herein and will be paid by Seller.

9. Warranty. Standard manufacturer warranties apply on all applicable products. For a period of ninety (90) days after delivery, the services will be free from defects in material and workmanship under normal use as intended. Seller's sole liability under the foregoing warranty, at Seller's sole election, is limited to replacement of Goods, repair of defects, or refund of the purchase price. Service and maintenance agreements can be included as an additional contract to any quote, but must be done in writing.

10. DISCLAIMER AND LIMITATION OF LIABILITY. EXCEPT AS SET FORTH ABOVE, SELLER MAKES NO WARRANTIES OF ANY KIND EITHER EXPRESS OR IMPLIED REGARDING THE GOODS. SELLER EXPRESSLY DISCLAIMS ANY IMPLIED WARRANTIES OF MERCHANTABILITY OR FITNESS FOR ANY PARTICULAR PURPOSE. IN RECOGNITION OF THE RELATIVE RISKS AND BENEFITS OF THIS AGREEMENT TO THE PARTIES, BUYER AGREES TO LIMIT SELLER'S TOTAL LIABILITY TO BUYER AND ANY OTHER THIRD PARTY FROM AND AGAINST ANY AND ALL CLAIMS, LOSSES, DAMAGES, LIABILITIES, COSTS, EXPENSES, JUDGMENTS, OR OBLIGATIONS WHATSOEVER, INCLUDING, BUT NOT LIMITED TO, REASONABLE ATTORNEYS' AND EXPERTS' FEES AND COSTS, FROM ANY CAUSE OR CAUSES, SUCH THAT SELLER'S TOTAL LIABILITY TO THOSE NAMED ABOVE SHALL NOT EXCEED THE TOTAL COMPENSATION PAID TO SELLER UNDER THIS AGREEMENT. THIS LIMITATION OF LIABILITY INCLUDES, BUT IS NOT LIMITED TO, ALLEGATIONS OR PROOF OF NEGLIGENCE, INDEMNITY, BREACH OF CONTRACT, STRICT LIABILITY, OR WARRANTY OR ANY OTHER CONTRACT OR TORT CLAIM PLEAD. SELLER SHALL NOT BE LIABLE, AND BUYER HEREBY WAIVES ANY AND ALL CLAIMS, FOR CONSEQUENTIAL DAMAGES, INCIDENTAL DAMAGES, ECONOMIC LOSS DAMAGES, and PUNITIVE DAMAGES (INCLUDING, WITHOUT LIMITATION, LOST PROFITS, DOWNTIME, LOST SAVINGS, COST OF PROCESSING, INJURY TO GOODWILL, REPRODUCTION COSTS, ETC) RELATING IN ANYWAY TO THIS AGREEMENT.

12. Risk of Loss. The risk of loss of the Goods shall pass to buyer as soon as the Goods are tendered to buyer. In the event the Goods are destroyed or damaged, in whole or in part, prior to the time the risk of loss passes to buyer, this agreement shall be voided and buyer excused from all obligations hereunder. If the loss is partial, buyer shall have the right to accept that portion of the Goods which conform to the agreement.

13. Rejected Goods. In the event buyer rejects any shipment of the Goods, and elects to accept only a part thereof, it is agreed that the portion of Goods rejected shall be returned to Seller within thirty (30) days of the invoice date and shall be at the expense and risk of buyer. Seller shall have the right in its discretion either to replace the rejected Goods or to refund the purchase price applicable thereto. All returns shall be subject to a re-stocking fee of twenty five percent (25%) of the purchased price of the products being returned and freight charges will apply.

14. Termination. Seller may, in its sole discretion, terminate this agreement and/or refuse to make any further deliveries, if buyer (i) fails to comply with any of these terms and conditions, (ii) becomes insolvent, (iii) violates any law, regulation or ordinance which may govern the sale, handling or disposition of any of the Custom Goods, (iv) makes any assignment for the benefit of creditors, or (v) is adjudged bankrupt.

15. Buyer's Remedies. In the event of a breach of this agreement by Seller, buyer's right to damages shall be limited to the difference between the contract and the market price of the Goods, and buyer shall not have the right to "cover" and fix damages by contracting for substitute Goods.

16. Assignment. Neither party may assign this agreement without the prior written consent of the other party.



Alpha Solutions, Inc.  
Tel: 949-415-2000  
info@alphaav.com  
<http://www.alphaav.com>

17. Force Majeure. Seller shall not be responsible for delays in delivery or any failure to deliver due to causes beyond Seller's reasonable control including, but not limited to, acts of God, war, mobilization, civil commissions, riots, embargoes, domestic or foreign governmental regulations or orders, fires, floods, strikes, lockouts and other labor difficulties, or shortages of or inability to obtain shipping space or transportation.

18. Choice of Law; Venue. This agreement and all of the rights and obligations of the parties hereto, are governed by the laws of the State of California. The parties agree that any and all lawsuits shall be filed in the County of Los Angeles. All disputes shall be submitted to non binding mediation prior to the filing of any lawsuit.

19. Authority. Buyer represents and warrants that (i) it has the full right, power, and authority to enter into this agreement and perform all of the obligations herein, and (ii) the person signing on behalf of buyer has the complete power and authority to bind the buyer to this agreement.

20. Entire Agreement. Once accepted, these terms and conditions, along with the Quote, constitute the entire agreement between buyer and Seller with respect to the Goods and may not be modified except by a writing signed by both parties.



Alpha Solutions, Inc.  
 Tel: 949-415-2000  
 info@alphaav.com  
 http://www.alphaav.com

Magnolia Public Schools  
 250 E. 1st Street  
 Los Angeles CA 90012

# Quotation # SO755

## MSA 1 75" Viewsonic with Hovermount

Quotation Date: 02/06/2019 00:37:38      Salesperson: Loren Greenshields      Expiration Date: 03/08/2019

DESCRIPTION	QUANTITY	UNIT PRICE	TAXES	AMOUNT
[IFP7550] ViewSonic 75" ViewBoard VIEWBOARD 75IN TCH LED LCD DISP 4K HDMI	20.000	3,100.00		\$ 62,000.00
[IFP-EW-70-02] IFP-EW-70-02 VIEWSONIC : 70- 79inch Interactive Display Extended On-Site Repair Warranty for 4th and 5th Year INCLUDED IN BOARD PRICE	20.000	0.00		\$ 0.00
[LB-WIFI-001] LB-WIFI-001 Wifi card INCLUDED IN BOARD PRICE	20.000	0.00		\$ 0.00
[Hovermount] Hovermount Flat Panel Mount, height adjustable up to 125lbs	20.000	430.00		\$ 8,600.00
NOTE: ViewSonic 75" is 128.97lbs - Manufacturer states this is within acceptable range up to +10lbs				
*Install - Install Hovermount on flat drywall, must have two(2) wood/metal studs available at 16" on center. Attach 75" ViewSonic to mount and adjust. Test and calibrate. (Two techs required due to size and weight) Alpha Solutions is C7 licensed and only uses our in house certified installers. COI by request.	20.000	225.00		\$ 4,500.00
ViewSonic training - 1 hour INCLUDED	1.000	0.00		\$ 0.00
Shipping - Free shipping for ViewSonic - Mount only shipping	1.000	550.00		\$ 550.00



Alpha Solutions, Inc.  
Tel: 949-415-2000  
info@alphaav.com  
<http://www.alphaav.com>

Subtotal \$ 75,650.00

---

Total \$ 75,650.00

---



Alpha Solutions, Inc.  
Tel: 949-415-2000  
info@alphaav.com  
http://www.alphaav.com

The above prices, specifications, and conditions are satisfactory and are hereby accepted. Alpha is authorized to do the work as specified. The signature on this contract is evidence of acceptance of all terms and conditions within.

Signature: \_\_\_\_\_ Date: \_\_\_\_\_

**To Order:**

For existing customers, please submit a copy of the approved quotation along with a PO and/or deposit/payment (check or credit card authorization), in accordance with your pre-set credit terms, to SALES@alphaav.com . For new customers, please contact your Sales Representative to discuss payment options, or to setup credit terms.

**Return Policy:**

Product must be returned within 30 days of invoice date and be in new factory fresh condition along with original packaging. Restocking fees and freight charges will apply. These prices may not include applicable taxes, insurance, shipping, delivery, setup fees, or any cables or cabling services or material unless specifically listed above.

**Additional Terms and Conditions:**

By accepting this quote, you agree to the Terms and Conditions below. Past due invoices are subject to a 1.5% monthly interest charge.

**TERMS AND CONDITIONS FOR SALE OF GOODS:**

1. Quote. These terms and conditions are deemed incorporated into the attached quote for goods and/or services ("Quote"). This Quote will remain open for thirty (30) days. Upon buyer's acceptance of the Quote, whether verbally or in writing, buyer will become bound to the Quote and the terms and conditions set forth herein. In the event that buyer submits a purchase order with additional terms and conditions, then buyer's additional terms and conditions shall not become part of the agreement between the parties unless Alpha Solutions Inc. ("Seller") acknowledges receipt of such in writing and the parties each sign an amendment to this agreement.
2. Goods. Seller agrees to sell and buyer agrees to buy the goods described in the Quote or which comply with buyer's written specifications ("Goods").
3. Payment. Buyer will promptly pay all sums upon tender of delivery, but in no event later than thirty (30) days after the invoice date. All late payments shall incur a service charge in the amount of one and a half percent (1.5%) per month and a late fee equivalent to one and a half percent (1.5%) of the total amount invoiced. Any deviation from quoted specifications requested by buyer will require management approval which will be provided in writing upon approval.
4. Shipping. Goods are sold F.O.B. destination, title and risk remain with Seller until goods are delivered to the location specified in the contract.
5. Taxes. Prices are subject to all federal, state and local excise, sales, use and similar taxes, if any.
6. Delivery. The delivery of Goods will be made, in single or multiple lots, as specified herein and will be made on or before the date specified herein, or within a reasonable time thereafter. The delivery schedule hereof shall be considered extended by a period of time equal to the time lost because of any delay, which is due to causes beyond Seller's reasonable control. All installments will be separately invoiced and paid as billed without regard to future deliveries. Failure to pay for any installment when due shall excuse Seller from making further deliveries. Delay in delivery of any installment shall not relieve buyer of its obligation to accept remaining installments. All claims for delay shall be deemed waived, unless presented to Seller in writing within ten (10) days after delivery of each shipment. The Goods shall be delivered to the place identified in the Quote.



Alpha Solutions, Inc.  
Tel: 949-415-2000  
info@alphaav.com  
<http://www.alphaav.com>

7. Shipment Under Reservation. Seller will maintain title and the right of possession in the Goods sold until payment thereof is made by buyer.

8. Packaging. Seller/Manufacturer will determine the type of container and arrange for suitable packaging for domestic transport and delivery of the Goods, and charges related thereto are included in the price for the Goods set forth herein and will be paid by Seller.

9. Warranty. Standard manufacturer warranties apply on all applicable products. For a period of ninety (90) days after delivery, the services will be free from defects in material and workmanship under normal use as intended. Seller's sole liability under the foregoing warranty, at Seller's sole election, is limited to replacement of Goods, repair of defects, or refund of the purchase price. Service and maintenance agreements can be included as an additional contract to any quote, but must be done in writing.

10. DISCLAIMER AND LIMITATION OF LIABILITY. EXCEPT AS SET FORTH ABOVE, SELLER MAKES NO WARRANTIES OF ANY KIND EITHER EXPRESS OR IMPLIED REGARDING THE GOODS. SELLER EXPRESSLY DISCLAIMS ANY IMPLIED WARRANTIES OF MERCHANTABILITY OR FITNESS FOR ANY PARTICULAR PURPOSE. IN RECOGNITION OF THE RELATIVE RISKS AND BENEFITS OF THIS AGREEMENT TO THE PARTIES, BUYER AGREES TO LIMIT SELLER'S TOTAL LIABILITY TO BUYER AND ANY OTHER THIRD PARTY FROM AND AGAINST ANY AND ALL CLAIMS, LOSSES, DAMAGES, LIABILITIES, COSTS, EXPENSES, JUDGMENTS, OR OBLIGATIONS WHATSOEVER, INCLUDING, BUT NOT LIMITED TO, REASONABLE ATTORNEYS' AND EXPERTS' FEES AND COSTS, FROM ANY CAUSE OR CAUSES, SUCH THAT SELLER'S TOTAL LIABILITY TO THOSE NAMED ABOVE SHALL NOT EXCEED THE TOTAL COMPENSATION PAID TO SELLER UNDER THIS AGREEMENT. THIS LIMITATION OF LIABILITY INCLUDES, BUT IS NOT LIMITED TO, ALLEGATIONS OR PROOF OF NEGLIGENCE, INDEMNITY, BREACH OF CONTRACT, STRICT LIABILITY, OR WARRANTY OR ANY OTHER CONTRACT OR TORT CLAIM PLEAD. SELLER SHALL NOT BE LIABLE, AND BUYER HEREBY WAIVES ANY AND ALL CLAIMS, FOR CONSEQUENTIAL DAMAGES, INCIDENTAL DAMAGES, ECONOMIC LOSS DAMAGES, and PUNITIVE DAMAGES (INCLUDING, WITHOUT LIMITATION, LOST PROFITS, DOWNTIME, LOST SAVINGS, COST OF PROCESSING, INJURY TO GOODWILL, REPRODUCTION COSTS, ETC) RELATING IN ANYWAY TO THIS AGREEMENT.

12. Risk of Loss. The risk of loss of the Goods shall pass to buyer as soon as the Goods are tendered to buyer. In the event the Goods are destroyed or damaged, in whole or in part, prior to the time the risk of loss passes to buyer, this agreement shall be voided and buyer excused from all obligations hereunder. If the loss is partial, buyer shall have the right to accept that portion of the Goods which conform to the agreement.

13. Rejected Goods. In the event buyer rejects any shipment of the Goods, and elects to accept only a part thereof, it is agreed that the portion of Goods rejected shall be returned to Seller within thirty (30) days of the invoice date and shall be at the expense and risk of buyer. Seller shall have the right in its discretion either to replace the rejected Goods or to refund the purchase price applicable thereto. All returns shall be subject to a re-stocking fee of twenty five percent (25%) of the purchased price of the products being returned and freight charges will apply.

14. Termination. Seller may, in its sole discretion, terminate this agreement and/or refuse to make any further deliveries, if buyer (i) fails to comply with any of these terms and conditions, (ii) becomes insolvent, (iii) violates any law, regulation or ordinance which may govern the sale, handling or disposition of any of the Custom Goods, (iv) makes any assignment for the benefit of creditors, or (v) is adjudged bankrupt.

15. Buyer's Remedies. In the event of a breach of this agreement by Seller, buyer's right to damages shall be limited to the difference between the contract and the market price of the Goods, and buyer shall not have the right to "cover" and fix damages by contracting for substitute Goods.

16. Assignment. Neither party may assign this agreement without the prior written consent of the other party.





Alpha Solutions, Inc.  
Tel: 949-415-2000  
info@alphaav.com  
<http://www.alphaav.com>

17. Force Majeure. Seller shall not be responsible for delays in delivery or any failure to deliver due to causes beyond Seller's reasonable control including, but not limited to, acts of God, war, mobilization, civil commissions, riots, embargoes, domestic or foreign governmental regulations or orders, fires, floods, strikes, lockouts and other labor difficulties, or shortages of or inability to obtain shipping space or transportation.

18. Choice of Law; Venue. This agreement and all of the rights and obligations of the parties hereto, are governed by the laws of the State of California. The parties agree that any and all lawsuits shall be filed in the County of Los Angeles. All disputes shall be submitted to non binding mediation prior to the filing of any lawsuit.

19. Authority. Buyer represents and warrants that (i) it has the full right, power, and authority to enter into this agreement and perform all of the obligations herein, and (ii) the person signing on behalf of buyer has the complete power and authority to bind the buyer to this agreement.

20. Entire Agreement. Once accepted, these terms and conditions, along with the Quote, constitute the entire agreement between buyer and Seller with respect to the Goods and may not be modified except by a writing signed by both parties.



Alpha Solutions, Inc.  
 Tel: 949-415-2000  
 info@alphaav.com  
 http://www.alphaav.com

Magnolia Public Schools  
 250 E. 1st Street  
 Los Angeles CA 90012

# Quotation # SO757

## MSA1 75" Viewsonic with rolling cart

Quotation Date:  
02/06/2019 01:42:47

Salesperson:  
Loren Greenshields

Expiration Date:  
03/08/2019

DESCRIPTION	QUANTITY	UNIT PRICE	TAXES	AMOUNT
[IFP7550] ViewSonic 75" ViewBoard VIEWBOARD 75IN TCH LED LCD DISP 4K HDMI	20.000	3,100.00	Sales Tax	\$ 62,000.00
[IFP-EW-70-02] IFP-EW-70-02 VIEWSONIC : 70- 79inch Interactive Display Extended On-Site Repair Warranty for 4th and 5th Year INCLUDED IN BOARD PRICE	20.000	0.00	Sales Tax	\$ 0.00
[LB-WIFI-001] LB-WIFI-001 Wifi card INCLUDED IN BOARD PRICE	20.000	0.00	Sales Tax	\$ 0.00
[VB-STND-001 ] VB-STND-001 Mobile Trolley Cart, ADA compliant for ViewBoard interactive flat panel displays.	20.000	388.00	Sales Tax	\$ 7,760.00
MAGNOLIA PUBLIC SCHOOLS ONLY				
ViewSonic training - 1 hour INCLUDED	1.000	0.00	Sales Tax	\$ 0.00
Shipping - Free shipping for all ViewSonic products	1.000	0.00	Sales Tax	\$ 0.00
<b>Subtotal</b>				\$ 69,760.00
Taxes on \$ 69,760.00				\$ 6,627.20



Alpha Solutions, Inc.  
Tel: 949-415-2000  
info@alphaav.com  
<http://www.alphaav.com>

---

Total \$ 76,387.20

---



Alpha Solutions, Inc.  
Tel: 949-415-2000  
info@alphaav.com  
http://www.alphaav.com

The above prices, specifications, and conditions are satisfactory and are hereby accepted. Alpha is authorized to do the work as specified. The signature on this contract is evidence of acceptance of all terms and conditions within.

Signature: \_\_\_\_\_ Date: \_\_\_\_\_

**To Order:**

For existing customers, please submit a copy of the approved quotation along with a PO and/or deposit/payment (check or credit card authorization), in accordance with your pre-set credit terms, to SALES@alphaav.com . For new customers, please contact your Sales Representative to discuss payment options, or to setup credit terms.

**Return Policy:**

Product must be returned within 30 days of invoice date and be in new factory fresh condition along with original packaging. Restocking fees and freight charges will apply. These prices may not include applicable taxes, insurance, shipping, delivery, setup fees, or any cables or cabling services or material unless specifically listed above.

**Additional Terms and Conditions:**

By accepting this quote, you agree to the Terms and Conditions below. Past due invoices are subject to a 1.5% monthly interest charge.

**TERMS AND CONDITIONS FOR SALE OF GOODS:**

1. Quote. These terms and conditions are deemed incorporated into the attached quote for goods and/or services ("Quote"). This Quote will remain open for thirty (30) days. Upon buyer's acceptance of the Quote, whether verbally or in writing, buyer will become bound to the Quote and the terms and conditions set forth herein. In the event that buyer submits a purchase order with additional terms and conditions, then buyer's additional terms and conditions shall not become part of the agreement between the parties unless Alpha Solutions Inc. ("Seller") acknowledges receipt of such in writing and the parties each sign an amendment to this agreement.
2. Goods. Seller agrees to sell and buyer agrees to buy the goods described in the Quote or which comply with buyer's written specifications ("Goods").
3. Payment. Buyer will promptly pay all sums upon tender of delivery, but in no event later than thirty (30) days after the invoice date. All late payments shall incur a service charge in the amount of one and a half percent (1.5%) per month and a late fee equivalent to one and a half percent (1.5%) of the total amount invoiced. Any deviation from quoted specifications requested by buyer will require management approval which will be provided in writing upon approval.
4. Shipping. Goods are sold F.O.B. destination, title and risk remain with Seller until goods are delivered to the location specified in the contract.
5. Taxes. Prices are subject to all federal, state and local excise, sales, use and similar taxes, if any.
6. Delivery. The delivery of Goods will be made, in single or multiple lots, as specified herein and will be made on or before the date specified herein, or within a reasonable time thereafter. The delivery schedule hereof shall be considered extended by a period of time equal to the time lost because of any delay, which is due to causes beyond Seller's reasonable control. All installments will be separately invoiced and paid as billed without regard to future deliveries. Failure to pay for any installment when due shall excuse Seller from making further deliveries. Delay in delivery of any installment shall not relieve buyer of its obligation to accept remaining installments. All claims for delay shall be deemed waived, unless presented to Seller in writing within ten (10) days after delivery of each shipment. The Goods shall be delivered to the place identified in the Quote.



Alpha Solutions, Inc.  
Tel: 949-415-2000  
info@alphaav.com  
<http://www.alphaav.com>

7. Shipment Under Reservation. Seller will maintain title and the right of possession in the Goods sold until payment thereof is made by buyer.

8. Packaging. Seller/Manufacturer will determine the type of container and arrange for suitable packaging for domestic transport and delivery of the Goods, and charges related thereto are included in the price for the Goods set forth herein and will be paid by Seller.

9. Warranty. Standard manufacturer warranties apply on all applicable products. For a period of ninety (90) days after delivery, the services will be free from defects in material and workmanship under normal use as intended. Seller's sole liability under the foregoing warranty, at Seller's sole election, is limited to replacement of Goods, repair of defects, or refund of the purchase price. Service and maintenance agreements can be included as an additional contract to any quote, but must be done in writing.

10. DISCLAIMER AND LIMITATION OF LIABILITY. EXCEPT AS SET FORTH ABOVE, SELLER MAKES NO WARRANTIES OF ANY KIND EITHER EXPRESS OR IMPLIED REGARDING THE GOODS. SELLER EXPRESSLY DISCLAIMS ANY IMPLIED WARRANTIES OF MERCHANTABILITY OR FITNESS FOR ANY PARTICULAR PURPOSE. IN RECOGNITION OF THE RELATIVE RISKS AND BENEFITS OF THIS AGREEMENT TO THE PARTIES, BUYER AGREES TO LIMIT SELLER'S TOTAL LIABILITY TO BUYER AND ANY OTHER THIRD PARTY FROM AND AGAINST ANY AND ALL CLAIMS, LOSSES, DAMAGES, LIABILITIES, COSTS, EXPENSES, JUDGMENTS, OR OBLIGATIONS WHATSOEVER, INCLUDING, BUT NOT LIMITED TO, REASONABLE ATTORNEYS' AND EXPERTS' FEES AND COSTS, FROM ANY CAUSE OR CAUSES, SUCH THAT SELLER'S TOTAL LIABILITY TO THOSE NAMED ABOVE SHALL NOT EXCEED THE TOTAL COMPENSATION PAID TO SELLER UNDER THIS AGREEMENT. THIS LIMITATION OF LIABILITY INCLUDES, BUT IS NOT LIMITED TO, ALLEGATIONS OR PROOF OF NEGLIGENCE, INDEMNITY, BREACH OF CONTRACT, STRICT LIABILITY, OR WARRANTY OR ANY OTHER CONTRACT OR TORT CLAIM PLEAD. SELLER SHALL NOT BE LIABLE, AND BUYER HEREBY WAIVES ANY AND ALL CLAIMS, FOR CONSEQUENTIAL DAMAGES, INCIDENTAL DAMAGES, ECONOMIC LOSS DAMAGES, and PUNITIVE DAMAGES (INCLUDING, WITHOUT LIMITATION, LOST PROFITS, DOWNTIME, LOST SAVINGS, COST OF PROCESSING, INJURY TO GOODWILL, REPRODUCTION COSTS, ETC) RELATING IN ANYWAY TO THIS AGREEMENT.

12. Risk of Loss. The risk of loss of the Goods shall pass to buyer as soon as the Goods are tendered to buyer. In the event the Goods are destroyed or damaged, in whole or in part, prior to the time the risk of loss passes to buyer, this agreement shall be voided and buyer excused from all obligations hereunder. If the loss is partial, buyer shall have the right to accept that portion of the Goods which conform to the agreement.

13. Rejected Goods. In the event buyer rejects any shipment of the Goods, and elects to accept only a part thereof, it is agreed that the portion of Goods rejected shall be returned to Seller within thirty (30) days of the invoice date and shall be at the expense and risk of buyer. Seller shall have the right in its discretion either to replace the rejected Goods or to refund the purchase price applicable thereto. All returns shall be subject to a re-stocking fee of twenty five percent (25%) of the purchased price of the products being returned and freight charges will apply.

14. Termination. Seller may, in its sole discretion, terminate this agreement and/or refuse to make any further deliveries, if buyer (i) fails to comply with any of these terms and conditions, (ii) becomes insolvent, (iii) violates any law, regulation or ordinance which may govern the sale, handling or disposition of any of the Custom Goods, (iv) makes any assignment for the benefit of creditors, or (v) is adjudged bankrupt.

15. Buyer's Remedies. In the event of a breach of this agreement by Seller, buyer's right to damages shall be limited to the difference between the contract and the market price of the Goods, and buyer shall not have the right to "cover" and fix damages by contracting for substitute Goods.

16. Assignment. Neither party may assign this agreement without the prior written consent of the other party.



Alpha Solutions, Inc.  
Tel: 949-415-2000  
info@alphaav.com  
<http://www.alphaav.com>

17. Force Majeure. Seller shall not be responsible for delays in delivery or any failure to deliver due to causes beyond Seller's reasonable control including, but not limited to, acts of God, war, mobilization, civil commissions, riots, embargoes, domestic or foreign governmental regulations or orders, fires, floods, strikes, lockouts and other labor difficulties, or shortages of or inability to obtain shipping space or transportation.

18. Choice of Law; Venue. This agreement and all of the rights and obligations of the parties hereto, are governed by the laws of the State of California. The parties agree that any and all lawsuits shall be filed in the County of Los Angeles. All disputes shall be submitted to non binding mediation prior to the filing of any lawsuit.

19. Authority. Buyer represents and warrants that (i) it has the full right, power, and authority to enter into this agreement and perform all of the obligations herein, and (ii) the person signing on behalf of buyer has the complete power and authority to bind the buyer to this agreement.

20. Entire Agreement. Once accepted, these terms and conditions, along with the Quote, constitute the entire agreement between buyer and Seller with respect to the Goods and may not be modified except by a writing signed by both parties.



Alpha Solutions, Inc.  
 Tel: 949-415-2000  
 info@alphaav.com  
 http://www.alphaav.com

Magnolia Public Schools  
 250 E. 1st Street  
 Los Angeles CA 90012

# Quotation # SO766

## MSA8 65" Viewsonic with Hovermount

Quotation Date:  
02/06/2019 19:55:46

Salesperson:  
Loren Greenshields

Expiration Date:  
03/08/2019

DESCRIPTION	QUANTITY	UNIT PRICE	TAXES	AMOUNT
[IFP6550] ViewSonic 65" ViewBoard Viewsonic 65" Viewboard	6.000	2,028.00	Sales Tax	\$ 12,168.00
[IFP-EW-65-02] IFP-EW-65-02 VIEWSONIC : 65- 75 inch Interactive Display Extended On-Site Repair Warranty for 4th and 5th Year INCLUDED IN BOARD PRICE	6.000	0.00	Sales Tax	\$ 0.00
[LB-WIFI-001] LB-WIFI-001 Wifi card INCLUDED IN BOARD PRICE	6.000	0.00	Sales Tax	\$ 0.00
[Hovermount] Hovermount Flat Panel Mount, height adjustable up to 125lbs	6.000	430.00	Sales Tax	\$ 2,580.00
NOTE: ViewSonic 75" is 128.97lbs - Manufacturer states this is within acceptable range up to +10lbs				
ViewSonic training - 1 hour INCLUDED	1.000	0.00	Sales Tax	\$ 0.00
Shipping - Free shipping for ViewSonic - Mount only shipping	1.000	178.00	Sales Tax	\$ 178.00
<b>Subtotal</b>				<b>\$ 14,926.00</b>
Taxes on \$ 14,926.00				\$ 1,401.06



Alpha Solutions, Inc.  
Tel: 949-415-2000  
info@alphaav.com  
<http://www.alphaav.com>

---

Total \$ 16,327.06

---





Alpha Solutions, Inc.  
Tel: 949-415-2000  
info@alphaav.com  
http://www.alphaav.com

The above prices, specifications, and conditions are satisfactory and are hereby accepted. Alpha is authorized to do the work as specified. The signature on this contract is evidence of acceptance of all terms and conditions within.

Signature: \_\_\_\_\_ Date: \_\_\_\_\_

**To Order:**

For existing customers, please submit a copy of the approved quotation along with a PO and/or deposit/payment (check or credit card authorization), in accordance with your pre-set credit terms, to SALES@alphaav.com . For new customers, please contact your Sales Representative to discuss payment options, or to setup credit terms.

**Return Policy:**

Product must be returned within 30 days of invoice date and be in new factory fresh condition along with original packaging. Restocking fees and freight charges will apply. These prices may not include applicable taxes, insurance, shipping, delivery, setup fees, or any cables or cabling services or material unless specifically listed above.

**Additional Terms and Conditions:**

By accepting this quote, you agree to the Terms and Conditions below. Past due invoices are subject to a 1.5% monthly interest charge.

**TERMS AND CONDITIONS FOR SALE OF GOODS:**

1. Quote. These terms and conditions are deemed incorporated into the attached quote for goods and/or services ("Quote"). This Quote will remain open for thirty (30) days. Upon buyer's acceptance of the Quote, whether verbally or in writing, buyer will become bound to the Quote and the terms and conditions set forth herein. In the event that buyer submits a purchase order with additional terms and conditions, then buyer's additional terms and conditions shall not become part of the agreement between the parties unless Alpha Solutions Inc. ("Seller") acknowledges receipt of such in writing and the parties each sign an amendment to this agreement.
2. Goods. Seller agrees to sell and buyer agrees to buy the goods described in the Quote or which comply with buyer's written specifications ("Goods").
3. Payment. Buyer will promptly pay all sums upon tender of delivery, but in no event later than thirty (30) days after the invoice date. All late payments shall incur a service charge in the amount of one and a half percent (1.5%) per month and a late fee equivalent to one and a half percent (1.5%) of the total amount invoiced. Any deviation from quoted specifications requested by buyer will require management approval which will be provided in writing upon approval.
4. Shipping. Goods are sold F.O.B. destination, title and risk remain with Seller until goods are delivered to the location specified in the contract.
5. Taxes. Prices are subject to all federal, state and local excise, sales, use and similar taxes, if any.
6. Delivery. The delivery of Goods will be made, in single or multiple lots, as specified herein and will be made on or before the date specified herein, or within a reasonable time thereafter. The delivery schedule hereof shall be considered extended by a period of time equal to the time lost because of any delay, which is due to causes beyond Seller's reasonable control. All installments will be separately invoiced and paid as billed without regard to future deliveries. Failure to pay for any installment when due shall excuse Seller from making further deliveries. Delay in delivery of any installment shall not relieve buyer of its obligation to accept remaining installments. All claims for delay shall be deemed waived, unless presented to Seller in writing within ten (10) days after delivery of each shipment. The Goods shall be delivered to the place identified in the Quote.



Alpha Solutions, Inc.  
Tel: 949-415-2000  
info@alphaav.com  
<http://www.alphaav.com>

7. Shipment Under Reservation. Seller will maintain title and the right of possession in the Goods sold until payment thereof is made by buyer.

8. Packaging. Seller/Manufacturer will determine the type of container and arrange for suitable packaging for domestic transport and delivery of the Goods, and charges related thereto are included in the price for the Goods set forth herein and will be paid by Seller.

9. Warranty. Standard manufacturer warranties apply on all applicable products. For a period of ninety (90) days after delivery, the services will be free from defects in material and workmanship under normal use as intended. Seller's sole liability under the foregoing warranty, at Seller's sole election, is limited to replacement of Goods, repair of defects, or refund of the purchase price. Service and maintenance agreements can be included as an additional contract to any quote, but must be done in writing.

10. DISCLAIMER AND LIMITATION OF LIABILITY. EXCEPT AS SET FORTH ABOVE, SELLER MAKES NO WARRANTIES OF ANY KIND EITHER EXPRESS OR IMPLIED REGARDING THE GOODS. SELLER EXPRESSLY DISCLAIMS ANY IMPLIED WARRANTIES OF MERCHANTABILITY OR FITNESS FOR ANY PARTICULAR PURPOSE. IN RECOGNITION OF THE RELATIVE RISKS AND BENEFITS OF THIS AGREEMENT TO THE PARTIES, BUYER AGREES TO LIMIT SELLER'S TOTAL LIABILITY TO BUYER AND ANY OTHER THIRD PARTY FROM AND AGAINST ANY AND ALL CLAIMS, LOSSES, DAMAGES, LIABILITIES, COSTS, EXPENSES, JUDGMENTS, OR OBLIGATIONS WHATSOEVER, INCLUDING, BUT NOT LIMITED TO, REASONABLE ATTORNEYS' AND EXPERTS' FEES AND COSTS, FROM ANY CAUSE OR CAUSES, SUCH THAT SELLER'S TOTAL LIABILITY TO THOSE NAMED ABOVE SHALL NOT EXCEED THE TOTAL COMPENSATION PAID TO SELLER UNDER THIS AGREEMENT. THIS LIMITATION OF LIABILITY INCLUDES, BUT IS NOT LIMITED TO, ALLEGATIONS OR PROOF OF NEGLIGENCE, INDEMNITY, BREACH OF CONTRACT, STRICT LIABILITY, OR WARRANTY OR ANY OTHER CONTRACT OR TORT CLAIM PLEAD. SELLER SHALL NOT BE LIABLE, AND BUYER HEREBY WAIVES ANY AND ALL CLAIMS, FOR CONSEQUENTIAL DAMAGES, INCIDENTAL DAMAGES, ECONOMIC LOSS DAMAGES, and PUNITIVE DAMAGES (INCLUDING, WITHOUT LIMITATION, LOST PROFITS, DOWNTIME, LOST SAVINGS, COST OF PROCESSING, INJURY TO GOODWILL, REPRODUCTION COSTS, ETC) RELATING IN ANYWAY TO THIS AGREEMENT.

12. Risk of Loss. The risk of loss of the Goods shall pass to buyer as soon as the Goods are tendered to buyer. In the event the Goods are destroyed or damaged, in whole or in part, prior to the time the risk of loss passes to buyer, this agreement shall be voided and buyer excused from all obligations hereunder. If the loss is partial, buyer shall have the right to accept that portion of the Goods which conform to the agreement.

13. Rejected Goods. In the event buyer rejects any shipment of the Goods, and elects to accept only a part thereof, it is agreed that the portion of Goods rejected shall be returned to Seller within thirty (30) days of the invoice date and shall be at the expense and risk of buyer. Seller shall have the right in its discretion either to replace the rejected Goods or to refund the purchase price applicable thereto. All returns shall be subject to a re-stocking fee of twenty five percent (25%) of the purchased price of the products being returned and freight charges will apply.

14. Termination. Seller may, in its sole discretion, terminate this agreement and/or refuse to make any further deliveries, if buyer (i) fails to comply with any of these terms and conditions, (ii) becomes insolvent, (iii) violates any law, regulation or ordinance which may govern the sale, handling or disposition of any of the Custom Goods, (iv) makes any assignment for the benefit of creditors, or (v) is adjudged bankrupt.

15. Buyer's Remedies. In the event of a breach of this agreement by Seller, buyer's right to damages shall be limited to the difference between the contract and the market price of the Goods, and buyer shall not have the right to "cover" and fix damages by contracting for substitute Goods.

16. Assignment. Neither party may assign this agreement without the prior written consent of the other party.



Alpha Solutions, Inc.  
Tel: 949-415-2000  
info@alphaav.com  
<http://www.alphaav.com>

17. Force Majeure. Seller shall not be responsible for delays in delivery or any failure to deliver due to causes beyond Seller's reasonable control including, but not limited to, acts of God, war, mobilization, civil commissions, riots, embargoes, domestic or foreign governmental regulations or orders, fires, floods, strikes, lockouts and other labor difficulties, or shortages of or inability to obtain shipping space or transportation.

18. Choice of Law; Venue. This agreement and all of the rights and obligations of the parties hereto, are governed by the laws of the State of California. The parties agree that any and all lawsuits shall be filed in the County of Los Angeles. All disputes shall be submitted to non binding mediation prior to the filing of any lawsuit.

19. Authority. Buyer represents and warrants that (i) it has the full right, power, and authority to enter into this agreement and perform all of the obligations herein, and (ii) the person signing on behalf of buyer has the complete power and authority to bind the buyer to this agreement.

20. Entire Agreement. Once accepted, these terms and conditions, along with the Quote, constitute the entire agreement between buyer and Seller with respect to the Goods and may not be modified except by a writing signed by both parties.



Alpha Solutions, Inc.  
 Tel: 949-415-2000  
 info@alphaav.com  
 http://www.alphaav.com

Magnolia Public Schools  
 250 E. 1st Street  
 Los Angeles CA 90012

# Quotation # SO767

## MSA8 65" Viewsonic with rolling cart

Quotation Date:  
02/06/2019 19:59:38

Salesperson:  
Loren Greenshields

Expiration Date:  
03/08/2019

DESCRIPTION	QUANTITY	UNIT PRICE	TAXES	AMOUNT
[IFP6550] ViewSonic 65" ViewBoard Viewsonic 65" Viewboard	6.000	2,028.00	Sales Tax	\$ 12,168.00
[IFP-EW-65-02] IFP-EW-65-02 VIEWSONIC : 65- 70inch Interactive Display Extended On-Site Repair Warranty for 4th and 5th Year INCLUDED IN BOARD PRICE	6.000	0.00	Sales Tax	\$ 0.00
[LB-WIFI-001] LB-WIFI-001 Wifi card INCLUDED IN BOARD PRICE	6.000	0.00	Sales Tax	\$ 0.00
[VB-STND-001 ] VB-STND-001 Mobile Trolley Cart, ADA compliant for ViewBoard interactive flat panel displays.	6.000	388.00	Sales Tax	\$ 2,328.00
MAGNOLIA PUBLIC SCHOOLS ONLY				
ViewSonic training - 1 hour INCLUDED	1.000	0.00	Sales Tax	\$ 0.00
Shipping - Free shipping for all ViewSonic products	1.000	0.00	Sales Tax	\$ 0.00
<b>Subtotal</b>				<b>\$ 14,496.00</b>
Taxes on \$ 14,496.00				\$ 1,377.12



Alpha Solutions, Inc.  
Tel: 949-415-2000  
info@alphaav.com  
<http://www.alphaav.com>

---

Total \$ 15,873.12

---



Alpha Solutions, Inc.  
Tel: 949-415-2000  
info@alphaav.com  
http://www.alphaav.com

The above prices, specifications, and conditions are satisfactory and are hereby accepted. Alpha is authorized to do the work as specified. The signature on this contract is evidence of acceptance of all terms and conditions within.

Signature: \_\_\_\_\_ Date: \_\_\_\_\_

**To Order:**

For existing customers, please submit a copy of the approved quotation along with a PO and/or deposit/payment (check or credit card authorization), in accordance with your pre-set credit terms, to SALES@alphaav.com . For new customers, please contact your Sales Representative to discuss payment options, or to setup credit terms.

**Return Policy:**

Product must be returned within 30 days of invoice date and be in new factory fresh condition along with original packaging. Restocking fees and freight charges will apply. These prices may not include applicable taxes, insurance, shipping, delivery, setup fees, or any cables or cabling services or material unless specifically listed above.

**Additional Terms and Conditions:**

By accepting this quote, you agree to the Terms and Conditions below. Past due invoices are subject to a 1.5% monthly interest charge.

**TERMS AND CONDITIONS FOR SALE OF GOODS:**

1. Quote. These terms and conditions are deemed incorporated into the attached quote for goods and/or services ("Quote"). This Quote will remain open for thirty (30) days. Upon buyer's acceptance of the Quote, whether verbally or in writing, buyer will become bound to the Quote and the terms and conditions set forth herein. In the event that buyer submits a purchase order with additional terms and conditions, then buyer's additional terms and conditions shall not become part of the agreement between the parties unless Alpha Solutions Inc. ("Seller") acknowledges receipt of such in writing and the parties each sign an amendment to this agreement.
2. Goods. Seller agrees to sell and buyer agrees to buy the goods described in the Quote or which comply with buyer's written specifications ("Goods").
3. Payment. Buyer will promptly pay all sums upon tender of delivery, but in no event later than thirty (30) days after the invoice date. All late payments shall incur a service charge in the amount of one and a half percent (1.5%) per month and a late fee equivalent to one and a half percent (1.5%) of the total amount invoiced. Any deviation from quoted specifications requested by buyer will require management approval which will be provided in writing upon approval.
4. Shipping. Goods are sold F.O.B. destination, title and risk remain with Seller until goods are delivered to the location specified in the contract.
5. Taxes. Prices are subject to all federal, state and local excise, sales, use and similar taxes, if any.
6. Delivery. The delivery of Goods will be made, in single or multiple lots, as specified herein and will be made on or before the date specified herein, or within a reasonable time thereafter. The delivery schedule hereof shall be considered extended by a period of time equal to the time lost because of any delay, which is due to causes beyond Seller's reasonable control. All installments will be separately invoiced and paid as billed without regard to future deliveries. Failure to pay for any installment when due shall excuse Seller from making further deliveries. Delay in delivery of any installment shall not relieve buyer of its obligation to accept remaining installments. All claims for delay shall be deemed waived, unless presented to Seller in writing within ten (10) days after delivery of each shipment. The Goods shall be delivered to the place identified in the Quote.



Alpha Solutions, Inc.  
Tel: 949-415-2000  
info@alphaav.com  
<http://www.alphaav.com>

7. Shipment Under Reservation. Seller will maintain title and the right of possession in the Goods sold until payment thereof is made by buyer.

8. Packaging. Seller/Manufacturer will determine the type of container and arrange for suitable packaging for domestic transport and delivery of the Goods, and charges related thereto are included in the price for the Goods set forth herein and will be paid by Seller.

9. Warranty. Standard manufacturer warranties apply on all applicable products. For a period of ninety (90) days after delivery, the services will be free from defects in material and workmanship under normal use as intended. Seller's sole liability under the foregoing warranty, at Seller's sole election, is limited to replacement of Goods, repair of defects, or refund of the purchase price. Service and maintenance agreements can be included as an additional contract to any quote, but must be done in writing.

10. DISCLAIMER AND LIMITATION OF LIABILITY. EXCEPT AS SET FORTH ABOVE, SELLER MAKES NO WARRANTIES OF ANY KIND EITHER EXPRESS OR IMPLIED REGARDING THE GOODS. SELLER EXPRESSLY DISCLAIMS ANY IMPLIED WARRANTIES OF MERCHANTABILITY OR FITNESS FOR ANY PARTICULAR PURPOSE. IN RECOGNITION OF THE RELATIVE RISKS AND BENEFITS OF THIS AGREEMENT TO THE PARTIES, BUYER AGREES TO LIMIT SELLER'S TOTAL LIABILITY TO BUYER AND ANY OTHER THIRD PARTY FROM AND AGAINST ANY AND ALL CLAIMS, LOSSES, DAMAGES, LIABILITIES, COSTS, EXPENSES, JUDGMENTS, OR OBLIGATIONS WHATSOEVER, INCLUDING, BUT NOT LIMITED TO, REASONABLE ATTORNEYS' AND EXPERTS' FEES AND COSTS, FROM ANY CAUSE OR CAUSES, SUCH THAT SELLER'S TOTAL LIABILITY TO THOSE NAMED ABOVE SHALL NOT EXCEED THE TOTAL COMPENSATION PAID TO SELLER UNDER THIS AGREEMENT. THIS LIMITATION OF LIABILITY INCLUDES, BUT IS NOT LIMITED TO, ALLEGATIONS OR PROOF OF NEGLIGENCE, INDEMNITY, BREACH OF CONTRACT, STRICT LIABILITY, OR WARRANTY OR ANY OTHER CONTRACT OR TORT CLAIM PLEAD. SELLER SHALL NOT BE LIABLE, AND BUYER HEREBY WAIVES ANY AND ALL CLAIMS, FOR CONSEQUENTIAL DAMAGES, INCIDENTAL DAMAGES, ECONOMIC LOSS DAMAGES, and PUNITIVE DAMAGES (INCLUDING, WITHOUT LIMITATION, LOST PROFITS, DOWNTIME, LOST SAVINGS, COST OF PROCESSING, INJURY TO GOODWILL, REPRODUCTION COSTS, ETC) RELATING IN ANYWAY TO THIS AGREEMENT.

12. Risk of Loss. The risk of loss of the Goods shall pass to buyer as soon as the Goods are tendered to buyer. In the event the Goods are destroyed or damaged, in whole or in part, prior to the time the risk of loss passes to buyer, this agreement shall be voided and buyer excused from all obligations hereunder. If the loss is partial, buyer shall have the right to accept that portion of the Goods which conform to the agreement.

13. Rejected Goods. In the event buyer rejects any shipment of the Goods, and elects to accept only a part thereof, it is agreed that the portion of Goods rejected shall be returned to Seller within thirty (30) days of the invoice date and shall be at the expense and risk of buyer. Seller shall have the right in its discretion either to replace the rejected Goods or to refund the purchase price applicable thereto. All returns shall be subject to a re-stocking fee of twenty five percent (25%) of the purchased price of the products being returned and freight charges will apply.

14. Termination. Seller may, in its sole discretion, terminate this agreement and/or refuse to make any further deliveries, if buyer (i) fails to comply with any of these terms and conditions, (ii) becomes insolvent, (iii) violates any law, regulation or ordinance which may govern the sale, handling or disposition of any of the Custom Goods, (iv) makes any assignment for the benefit of creditors, or (v) is adjudged bankrupt.

15. Buyer's Remedies. In the event of a breach of this agreement by Seller, buyer's right to damages shall be limited to the difference between the contract and the market price of the Goods, and buyer shall not have the right to "cover" and fix damages by contracting for substitute Goods.

16. Assignment. Neither party may assign this agreement without the prior written consent of the other party.



Alpha Solutions, Inc.  
Tel: 949-415-2000  
info@alphaav.com  
<http://www.alphaav.com>

17. Force Majeure. Seller shall not be responsible for delays in delivery or any failure to deliver due to causes beyond Seller's reasonable control including, but not limited to, acts of God, war, mobilization, civil commissions, riots, embargoes, domestic or foreign governmental regulations or orders, fires, floods, strikes, lockouts and other labor difficulties, or shortages of or inability to obtain shipping space or transportation.

18. Choice of Law; Venue. This agreement and all of the rights and obligations of the parties hereto, are governed by the laws of the State of California. The parties agree that any and all lawsuits shall be filed in the County of Los Angeles. All disputes shall be submitted to non binding mediation prior to the filing of any lawsuit.

19. Authority. Buyer represents and warrants that (i) it has the full right, power, and authority to enter into this agreement and perform all of the obligations herein, and (ii) the person signing on behalf of buyer has the complete power and authority to bind the buyer to this agreement.

20. Entire Agreement. Once accepted, these terms and conditions, along with the Quote, constitute the entire agreement between buyer and Seller with respect to the Goods and may not be modified except by a writing signed by both parties.





Alpha Solutions, Inc.  
 Tel: 949-415-2000  
 info@alphaav.com  
 http://www.alphaav.com

Magnolia Public Schools  
 250 E. 1st Street  
 Los Angeles CA 90012

# Quotation # SO761

## MSA8 75" Viewsonic with wall mount WMK-047-2

Quotation Date:  
02/06/2019 02:23:39

Salesperson:  
Loren Greenshields

Expiration Date:  
03/08/2019

DESCRIPTION	QUANTITY	UNIT PRICE	TAXES	AMOUNT
[IFP7550] ViewSonic 75" ViewBoard VIEWBOARD 75IN TCH LED LCD DISP 4K HDMI	6.000	3,100.00	Sales Tax	\$ 18,600.00
[IFP-EW-70-02] IFP-EW-70-02 VIEWSONIC : 70- 79inch Interactive Display Extended On-Site Repair Warranty for 4th and 5th Year INCLUDED IN BOARD PRICE	6.000	0.00	Sales Tax	\$ 0.00
[LB-WIFI-001] LB-WIFI-001 Wifi card INCLUDED IN BOARD PRICE	6.000	0.00	Sales Tax	\$ 0.00
WMK-047-2 Viewsonic Commercial display wall mount 75" interactive display. INCLUDED IN BOARD PRICE	1.000	0.00	Sales Tax	\$ 0.00
ViewSonic training - 1 hour INCLUDED	1.000	0.00	Sales Tax	\$ 0.00
Shipping - Free shipping for ViewSonic	1.000	0.00	Sales Tax	\$ 0.00
<b>Subtotal</b>				\$ 18,600.00
Taxes on \$ 18,600.00				\$ 1,767.00
<b>Total</b>				\$ 20,367.00



Alpha Solutions, Inc.  
Tel: 949-415-2000  
info@alphaav.com  
<http://www.alphaav.com>



Alpha Solutions, Inc.  
Tel: 949-415-2000  
info@alphaav.com  
http://www.alphaav.com

The above prices, specifications, and conditions are satisfactory and are hereby accepted. Alpha is authorized to do the work as specified. The signature on this contract is evidence of acceptance of all terms and conditions within.

Signature: \_\_\_\_\_ Date: \_\_\_\_\_

**To Order:**

For existing customers, please submit a copy of the approved quotation along with a PO and/or deposit/payment (check or credit card authorization), in accordance with your pre-set credit terms, to SALES@alphaav.com . For new customers, please contact your Sales Representative to discuss payment options, or to setup credit terms.

**Return Policy:**

Product must be returned within 30 days of invoice date and be in new factory fresh condition along with original packaging. Restocking fees and freight charges will apply. These prices may not include applicable taxes, insurance, shipping, delivery, setup fees, or any cables or cabling services or material unless specifically listed above.

**Additional Terms and Conditions:**

By accepting this quote, you agree to the Terms and Conditions below. Past due invoices are subject to a 1.5% monthly interest charge.

**TERMS AND CONDITIONS FOR SALE OF GOODS:**

1. **Quote.** These terms and conditions are deemed incorporated into the attached quote for goods and/or services ("Quote"). This Quote will remain open for thirty (30) days. Upon buyer's acceptance of the Quote, whether verbally or in writing, buyer will become bound to the Quote and the terms and conditions set forth herein. In the event that buyer submits a purchase order with additional terms and conditions, then buyer's additional terms and conditions shall not become part of the agreement between the parties unless Alpha Solutions Inc. ("Seller") acknowledges receipt of such in writing and the parties each sign an amendment to this agreement.
2. **Goods.** Seller agrees to sell and buyer agrees to buy the goods described in the Quote or which comply with buyer's written specifications ("Goods").
3. **Payment.** Buyer will promptly pay all sums upon tender of delivery, but in no event later than thirty (30) days after the invoice date. All late payments shall incur a service charge in the amount of one and a half percent (1.5%) per month and a late fee equivalent to one and a half percent (1.5%) of the total amount invoiced. Any deviation from quoted specifications requested by buyer will require management approval which will be provided in writing upon approval.
4. **Shipping.** Goods are sold F.O.B. destination, title and risk remain with Seller until goods are delivered to the location specified in the contract.
5. **Taxes.** Prices are subject to all federal, state and local excise, sales, use and similar taxes, if any.
6. **Delivery.** The delivery of Goods will be made, in single or multiple lots, as specified herein and will be made on or before the date specified herein, or within a reasonable time thereafter. The delivery schedule hereof shall be considered extended by a period of time equal to the time lost because of any delay, which is due to causes beyond Seller's reasonable control. All installments will be separately invoiced and paid as billed without regard to future deliveries. Failure to pay for any installment when due shall excuse Seller from making further deliveries. Delay in delivery of any installment shall not relieve buyer of its obligation to accept remaining installments. All claims for delay shall be deemed waived, unless presented to Seller in writing within ten (10) days after delivery of each shipment. The Goods shall be delivered to the place identified in the Quote.



Alpha Solutions, Inc.  
Tel: 949-415-2000  
info@alphaav.com  
<http://www.alphaav.com>

7. Shipment Under Reservation. Seller will maintain title and the right of possession in the Goods sold until payment thereof is made by buyer.

8. Packaging. Seller/Manufacturer will determine the type of container and arrange for suitable packaging for domestic transport and delivery of the Goods, and charges related thereto are included in the price for the Goods set forth herein and will be paid by Seller.

9. Warranty. Standard manufacturer warranties apply on all applicable products. For a period of ninety (90) days after delivery, the services will be free from defects in material and workmanship under normal use as intended. Seller's sole liability under the foregoing warranty, at Seller's sole election, is limited to replacement of Goods, repair of defects, or refund of the purchase price. Service and maintenance agreements can be included as an additional contract to any quote, but must be done in writing.

10. DISCLAIMER AND LIMITATION OF LIABILITY. EXCEPT AS SET FORTH ABOVE, SELLER MAKES NO WARRANTIES OF ANY KIND EITHER EXPRESS OR IMPLIED REGARDING THE GOODS. SELLER EXPRESSLY DISCLAIMS ANY IMPLIED WARRANTIES OF MERCHANTABILITY OR FITNESS FOR ANY PARTICULAR PURPOSE. IN RECOGNITION OF THE RELATIVE RISKS AND BENEFITS OF THIS AGREEMENT TO THE PARTIES, BUYER AGREES TO LIMIT SELLER'S TOTAL LIABILITY TO BUYER AND ANY OTHER THIRD PARTY FROM AND AGAINST ANY AND ALL CLAIMS, LOSSES, DAMAGES, LIABILITIES, COSTS, EXPENSES, JUDGMENTS, OR OBLIGATIONS WHATSOEVER, INCLUDING, BUT NOT LIMITED TO, REASONABLE ATTORNEYS' AND EXPERTS' FEES AND COSTS, FROM ANY CAUSE OR CAUSES, SUCH THAT SELLER'S TOTAL LIABILITY TO THOSE NAMED ABOVE SHALL NOT EXCEED THE TOTAL COMPENSATION PAID TO SELLER UNDER THIS AGREEMENT. THIS LIMITATION OF LIABILITY INCLUDES, BUT IS NOT LIMITED TO, ALLEGATIONS OR PROOF OF NEGLIGENCE, INDEMNITY, BREACH OF CONTRACT, STRICT LIABILITY, OR WARRANTY OR ANY OTHER CONTRACT OR TORT CLAIM PLEAD. SELLER SHALL NOT BE LIABLE, AND BUYER HEREBY WAIVES ANY AND ALL CLAIMS, FOR CONSEQUENTIAL DAMAGES, INCIDENTAL DAMAGES, ECONOMIC LOSS DAMAGES, and PUNITIVE DAMAGES (INCLUDING, WITHOUT LIMITATION, LOST PROFITS, DOWNTIME, LOST SAVINGS, COST OF PROCESSING, INJURY TO GOODWILL, REPRODUCTION COSTS, ETC) RELATING IN ANYWAY TO THIS AGREEMENT.

12. Risk of Loss. The risk of loss of the Goods shall pass to buyer as soon as the Goods are tendered to buyer. In the event the Goods are destroyed or damaged, in whole or in part, prior to the time the risk of loss passes to buyer, this agreement shall be voided and buyer excused from all obligations hereunder. If the loss is partial, buyer shall have the right to accept that portion of the Goods which conform to the agreement.

13. Rejected Goods. In the event buyer rejects any shipment of the Goods, and elects to accept only a part thereof, it is agreed that the portion of Goods rejected shall be returned to Seller within thirty (30) days of the invoice date and shall be at the expense and risk of buyer. Seller shall have the right in its discretion either to replace the rejected Goods or to refund the purchase price applicable thereto. All returns shall be subject to a re-stocking fee of twenty five percent (25%) of the purchased price of the products being returned and freight charges will apply.

14. Termination. Seller may, in its sole discretion, terminate this agreement and/or refuse to make any further deliveries, if buyer (i) fails to comply with any of these terms and conditions, (ii) becomes insolvent, (iii) violates any law, regulation or ordinance which may govern the sale, handling or disposition of any of the Custom Goods, (iv) makes any assignment for the benefit of creditors, or (v) is adjudged bankrupt.

15. Buyer's Remedies. In the event of a breach of this agreement by Seller, buyer's right to damages shall be limited to the difference between the contract and the market price of the Goods, and buyer shall not have the right to "cover" and fix damages by contracting for substitute Goods.

16. Assignment. Neither party may assign this agreement without the prior written consent of the other party.



Alpha Solutions, Inc.  
Tel: 949-415-2000  
info@alphaav.com  
<http://www.alphaav.com>

17. Force Majeure. Seller shall not be responsible for delays in delivery or any failure to deliver due to causes beyond Seller's reasonable control including, but not limited to, acts of God, war, mobilization, civil commissions, riots, embargoes, domestic or foreign governmental regulations or orders, fires, floods, strikes, lockouts and other labor difficulties, or shortages of or inability to obtain shipping space or transportation.

18. Choice of Law; Venue. This agreement and all of the rights and obligations of the parties hereto, are governed by the laws of the State of California. The parties agree that any and all lawsuits shall be filed in the County of Los Angeles. All disputes shall be submitted to non binding mediation prior to the filing of any lawsuit.

19. Authority. Buyer represents and warrants that (i) it has the full right, power, and authority to enter into this agreement and perform all of the obligations herein, and (ii) the person signing on behalf of buyer has the complete power and authority to bind the buyer to this agreement.

20. Entire Agreement. Once accepted, these terms and conditions, along with the Quote, constitute the entire agreement between buyer and Seller with respect to the Goods and may not be modified except by a writing signed by both parties.



Alpha Solutions, Inc.  
 Tel: 949-415-2000  
 info@alphaav.com  
 http://www.alphaav.com

Magnolia Public Schools  
 250 E. 1st Street  
 Los Angeles CA 90012

## Quotation # SO765 MSA8 75" Viewsonic with rolling cart

Quotation Date:  
 02/06/2019 19:51:47

Salesperson:  
 Loren Greenshields

Expiration Date:  
 03/08/2019

DESCRIPTION	QUANTITY	UNIT PRICE	TAXES	AMOUNT
[IFP7550] ViewSonic 75" ViewBoard VIEWBOARD 75IN TCH LED LCD DISP 4K HDMI	6.000	3,100.00	Sales Tax	\$ 18,600.00
[IFP-EW-70-02] IFP-EW-70-02 VIEWSONIC : 70- 79inch Interactive Display Extended On-Site Repair Warranty for 4th and 5th Year INCLUDED IN BOARD PRICE	6.000	0.00	Sales Tax	\$ 0.00
[LB-WIFI-001] LB-WIFI-001 Wifi card INCLUDED IN BOARD PRICE	6.000	0.00	Sales Tax	\$ 0.00
[VB-STND-001 ] VB-STND-001 Mobile Trolley Cart, ADA compliant for ViewBoard interactive flat panel displays.	6.000	388.00	Sales Tax	\$ 2,328.00
MAGNOLIA PUBLIC SCHOOLS ONLY				
ViewSonic training - 1 hour INCLUDED	1.000	0.00	Sales Tax	\$ 0.00
Shipping - Free shipping for all ViewSonic products	1.000	0.00	Sales Tax	\$ 0.00
<b>Subtotal</b>				\$ 20,928.00
Taxes on \$ 20,928.00				\$ 1,988.16



Alpha Solutions, Inc.  
Tel: 949-415-2000  
info@alphaav.com  
<http://www.alphaav.com>

---

Total \$ 22,916.16

---



Alpha Solutions, Inc.  
Tel: 949-415-2000  
info@alphaav.com  
http://www.alphaav.com

The above prices, specifications, and conditions are satisfactory and are hereby accepted. Alpha is authorized to do the work as specified. The signature on this contract is evidence of acceptance of all terms and conditions within.

Signature: \_\_\_\_\_ Date: \_\_\_\_\_

**To Order:**

For existing customers, please submit a copy of the approved quotation along with a PO and/or deposit/payment (check or credit card authorization), in accordance with your pre-set credit terms, to SALES@alphaav.com . For new customers, please contact your Sales Representative to discuss payment options, or to setup credit terms.

**Return Policy:**

Product must be returned within 30 days of invoice date and be in new factory fresh condition along with original packaging. Restocking fees and freight charges will apply. These prices may not include applicable taxes, insurance, shipping, delivery, setup fees, or any cables or cabling services or material unless specifically listed above.

**Additional Terms and Conditions:**

By accepting this quote, you agree to the Terms and Conditions below. Past due invoices are subject to a 1.5% monthly interest charge.

**TERMS AND CONDITIONS FOR SALE OF GOODS:**

1. Quote. These terms and conditions are deemed incorporated into the attached quote for goods and/or services ("Quote"). This Quote will remain open for thirty (30) days. Upon buyer's acceptance of the Quote, whether verbally or in writing, buyer will become bound to the Quote and the terms and conditions set forth herein. In the event that buyer submits a purchase order with additional terms and conditions, then buyer's additional terms and conditions shall not become part of the agreement between the parties unless Alpha Solutions Inc. ("Seller") acknowledges receipt of such in writing and the parties each sign an amendment to this agreement.
2. Goods. Seller agrees to sell and buyer agrees to buy the goods described in the Quote or which comply with buyer's written specifications ("Goods").
3. Payment. Buyer will promptly pay all sums upon tender of delivery, but in no event later than thirty (30) days after the invoice date. All late payments shall incur a service charge in the amount of one and a half percent (1.5%) per month and a late fee equivalent to one and a half percent (1.5%) of the total amount invoiced. Any deviation from quoted specifications requested by buyer will require management approval which will be provided in writing upon approval.
4. Shipping. Goods are sold F.O.B. destination, title and risk remain with Seller until goods are delivered to the location specified in the contract.
5. Taxes. Prices are subject to all federal, state and local excise, sales, use and similar taxes, if any.
6. Delivery. The delivery of Goods will be made, in single or multiple lots, as specified herein and will be made on or before the date specified herein, or within a reasonable time thereafter. The delivery schedule hereof shall be considered extended by a period of time equal to the time lost because of any delay, which is due to causes beyond Seller's reasonable control. All installments will be separately invoiced and paid as billed without regard to future deliveries. Failure to pay for any installment when due shall excuse Seller from making further deliveries. Delay in delivery of any installment shall not relieve buyer of its obligation to accept remaining installments. All claims for delay shall be deemed waived, unless presented to Seller in writing within ten (10) days after delivery of each shipment. The Goods shall be delivered to the place identified in the Quote.





Alpha Solutions, Inc.  
Tel: 949-415-2000  
info@alphaav.com  
<http://www.alphaav.com>

7. Shipment Under Reservation. Seller will maintain title and the right of possession in the Goods sold until payment thereof is made by buyer.

8. Packaging. Seller/Manufacturer will determine the type of container and arrange for suitable packaging for domestic transport and delivery of the Goods, and charges related thereto are included in the price for the Goods set forth herein and will be paid by Seller.

9. Warranty. Standard manufacturer warranties apply on all applicable products. For a period of ninety (90) days after delivery, the services will be free from defects in material and workmanship under normal use as intended. Seller's sole liability under the foregoing warranty, at Seller's sole election, is limited to replacement of Goods, repair of defects, or refund of the purchase price. Service and maintenance agreements can be included as an additional contract to any quote, but must be done in writing.

10. DISCLAIMER AND LIMITATION OF LIABILITY. EXCEPT AS SET FORTH ABOVE, SELLER MAKES NO WARRANTIES OF ANY KIND EITHER EXPRESS OR IMPLIED REGARDING THE GOODS. SELLER EXPRESSLY DISCLAIMS ANY IMPLIED WARRANTIES OF MERCHANTABILITY OR FITNESS FOR ANY PARTICULAR PURPOSE. IN RECOGNITION OF THE RELATIVE RISKS AND BENEFITS OF THIS AGREEMENT TO THE PARTIES, BUYER AGREES TO LIMIT SELLER'S TOTAL LIABILITY TO BUYER AND ANY OTHER THIRD PARTY FROM AND AGAINST ANY AND ALL CLAIMS, LOSSES, DAMAGES, LIABILITIES, COSTS, EXPENSES, JUDGMENTS, OR OBLIGATIONS WHATSOEVER, INCLUDING, BUT NOT LIMITED TO, REASONABLE ATTORNEYS' AND EXPERTS' FEES AND COSTS, FROM ANY CAUSE OR CAUSES, SUCH THAT SELLER'S TOTAL LIABILITY TO THOSE NAMED ABOVE SHALL NOT EXCEED THE TOTAL COMPENSATION PAID TO SELLER UNDER THIS AGREEMENT. THIS LIMITATION OF LIABILITY INCLUDES, BUT IS NOT LIMITED TO, ALLEGATIONS OR PROOF OF NEGLIGENCE, INDEMNITY, BREACH OF CONTRACT, STRICT LIABILITY, OR WARRANTY OR ANY OTHER CONTRACT OR TORT CLAIM PLEAD. SELLER SHALL NOT BE LIABLE, AND BUYER HEREBY WAIVES ANY AND ALL CLAIMS, FOR CONSEQUENTIAL DAMAGES, INCIDENTAL DAMAGES, ECONOMIC LOSS DAMAGES, and PUNITIVE DAMAGES (INCLUDING, WITHOUT LIMITATION, LOST PROFITS, DOWNTIME, LOST SAVINGS, COST OF PROCESSING, INJURY TO GOODWILL, REPRODUCTION COSTS, ETC) RELATING IN ANYWAY TO THIS AGREEMENT.

12. Risk of Loss. The risk of loss of the Goods shall pass to buyer as soon as the Goods are tendered to buyer. In the event the Goods are destroyed or damaged, in whole or in part, prior to the time the risk of loss passes to buyer, this agreement shall be voided and buyer excused from all obligations hereunder. If the loss is partial, buyer shall have the right to accept that portion of the Goods which conform to the agreement.

13. Rejected Goods. In the event buyer rejects any shipment of the Goods, and elects to accept only a part thereof, it is agreed that the portion of Goods rejected shall be returned to Seller within thirty (30) days of the invoice date and shall be at the expense and risk of buyer. Seller shall have the right in its discretion either to replace the rejected Goods or to refund the purchase price applicable thereto. All returns shall be subject to a re-stocking fee of twenty five percent (25%) of the purchased price of the products being returned and freight charges will apply.

14. Termination. Seller may, in its sole discretion, terminate this agreement and/or refuse to make any further deliveries, if buyer (i) fails to comply with any of these terms and conditions, (ii) becomes insolvent, (iii) violates any law, regulation or ordinance which may govern the sale, handling or disposition of any of the Custom Goods, (iv) makes any assignment for the benefit of creditors, or (v) is adjudged bankrupt.

15. Buyer's Remedies. In the event of a breach of this agreement by Seller, buyer's right to damages shall be limited to the difference between the contract and the market price of the Goods, and buyer shall not have the right to "cover" and fix damages by contracting for substitute Goods.

16. Assignment. Neither party may assign this agreement without the prior written consent of the other party.



Alpha Solutions, Inc.  
Tel: 949-415-2000  
info@alphaav.com  
<http://www.alphaav.com>

17. Force Majeure. Seller shall not be responsible for delays in delivery or any failure to deliver due to causes beyond Seller's reasonable control including, but not limited to, acts of God, war, mobilization, civil commissions, riots, embargoes, domestic or foreign governmental regulations or orders, fires, floods, strikes, lockouts and other labor difficulties, or shortages of or inability to obtain shipping space or transportation.

18. Choice of Law; Venue. This agreement and all of the rights and obligations of the parties hereto, are governed by the laws of the State of California. The parties agree that any and all lawsuits shall be filed in the County of Los Angeles. All disputes shall be submitted to non binding mediation prior to the filing of any lawsuit.

19. Authority. Buyer represents and warrants that (i) it has the full right, power, and authority to enter into this agreement and perform all of the obligations herein, and (ii) the person signing on behalf of buyer has the complete power and authority to bind the buyer to this agreement.

20. Entire Agreement. Once accepted, these terms and conditions, along with the Quote, constitute the entire agreement between buyer and Seller with respect to the Goods and may not be modified except by a writing signed by both parties.



## ELB's Proposal To:

---

# Magnolia Public Schools Magnolia Science Academy-1 and Magnolia Science Academy-8 Interactive Display Need

March 6, 2019

**From**

Jason Bruce and Christina Tehrani  
*Education Consultants*  
ELB US. Inc.  
11155 Knott Ave. Suite B  
Cypress, CA 90630  
(714) 458-1567  
[j.bruce@elbglobal.com](mailto:j.bruce@elbglobal.com)  
[c.tehrani@elbglobal.com](mailto:c.tehrani@elbglobal.com)



Google for Education  
Partner



---

## **Commercial in Confidence**

The information contained in this document is 'Commercial in Confidence' and the property of ELB US Inc. ("ELB").

The information contained herein has been provided for the sole purpose of assessing ELB's ability to undertake the project described.

Provision of this information should not be construed as a licence to copy or communicate this information to a third party without the express permission of ELB.

---

February 6, 2019

Rasul Monoshev  
MPS IT Director  
Magnolia Public Schools



**ELB** | CREATE. COMMUNICATE. COLLABORATE.

Dear Mr. Monoshev,

**ELB US Inc. (“ELB”) is pleased to present Magnolia Public Schools (“MPS”) this proposal for *Interactive Flat Panel Displays & Accessories*.**

As one of the world’s largest audio visual systems integration companies, we believe we have the experience, scale, commitment, and track record of success to deliver the products and services required in a manner which will exceed MPS’s expectations.

ELB is the exclusive distributor of Prowise Interactive Flat Panels in North America. With the distribution of Prowise comes a superior training and professional development plan that sets us apart from other audio visual integrators. ELB Education consists of credentialed teachers who have a passion for creating active learning spaces that center around teaching and learning first.

Our Prowise solution will be supported from end-to-end. Professional development, content creation seminars, and RMA equipment on-site are just a few of our support activities. With over 30 years of providing this type of support schools just like MPS, we are confident in our ability to help you succeed.

Contained in this proposal are the following:

- ELB company profile
- Description, pricing and technical brochures for our proposed classroom technology
- ELB’s support capabilities, services, and nominated staff for MPS
- Customer references and project profiles of similar size or interest

We hope the following information demonstrates ELB’s capability for delivering high quality, large scale implementations, and gives Magnolia Public Schools an understanding of the superior experience they can expect by working with us.

Yours sincerely,

**Jason Bruce, M.Ed**  
Education Consultant  
ELB US Inc.  
Ph: 714-458-1567

---

## TABLE OF CONTENTS

<b>WHY PROWISE? WHY ELB?</b> .....	<b>6</b>
WHY PROWISE?.....	7
WHY ELB?.....	9
<b>COMPANY OVERVIEW</b> .....	<b>11</b>
BACKGROUND.....	12
SCHOOL MANAGEMENT.....	16
TRAINING AND PROFESSIONAL DEVELOPMENT.....	18
<b>PRODUCT QUOTES, PRODUCT DETAILS AND SAMPLE INSTALLATION</b> .....	<b>19</b>
PROWISE BUNDLES AND QUOTATIONS.....	20
PROWISE PRODUCT DESCRIPTION.....	23
PROWISE PRESENTER AND REFLECT.....	25
SAMPLE INSTALLATION SCHEDULE MOBILE UNITS.....	27
SAMPLE INSTALLATION SCHEDULE WALL MOUNTED.....	27
<b>EXPERIENCE AND QUALIFICATIONS OF STAFF</b> .....	<b>29</b>
OUR COMMITMENT TO EDUCATION.....	30
EXPERIENCED AND DEDICATED MPS-ELB TEAM.....	32
KEY PERSONNEL BIOGRAPHIES.....	33
<b>PAST EXPERIENCE, PERFORMANCE AND REFERENCES</b> .....	<b>36</b>
SAUGUS USD-FULL TECHNOLOGY ROLL OUT.....	37
FACEBOOK-GLOBAL HEAD OFFICE.....	38
NSW DEPARTMENT OF EDUCATION.....	39
GOOGLE.....	40
REFERENCES.....	41
<b>TERMS &amp; CONDITIONS, INCLUSIONS &amp; EXCLUSIONS, PAYMENT TERMS</b> .....	<b>42</b>

---

TERMS & CONDITIONS.....	43
INCLUSIONS & EXCLUSIONS.....	45
PAYMENT TERMS.....	46
<b>TECHNICAL SUPPORT, WARRANTY AND REPAIR.....</b>	<b>47</b>
TECHNICAL SUPPORT AND REPAIR.....	48
<b>TECHNICAL SPECIFICATION SHEETS</b>	

# Why Prowise? Why ELB?

---



**ELB**

CREATE.  
COMMUNICATE.  
COLLABORATE.



## WHY PROWISE?

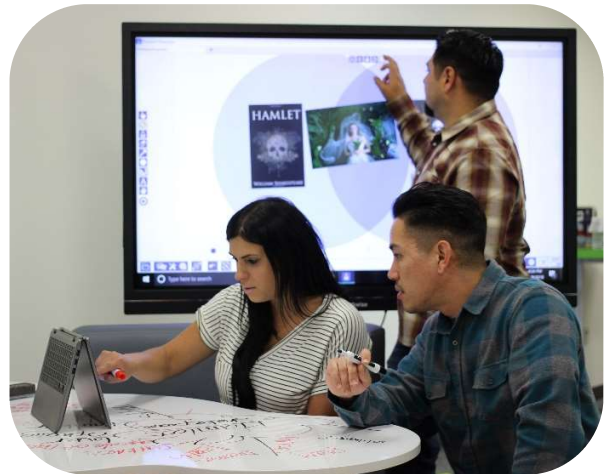

---

## FLEXIBLE TECHNOLOGY FOR FLEXIBLE LEARNING

Today's classrooms are changing. Students are in pods, modular desks get shuffled around, and there is no "front of the room." Why invest in fixed technology when everyone else around it is flexible? Our Prowise bundles were designed with this type of mobile, flexible classroom in mind.

- **Combine a high-resolution interactive panel with an All-in-One mobile lift system, built-in pc module, and speakers and you have the most flexible, value-added classroom collaboration tool**
- **A single power cord is all that's required to create an engaging learning space anywhere in the class**
- **Tilting the panel into a drafting table creates a unique learning station, whereas putting the lift into table mode is the ultimate group collaboration device**

## INNOVATIONS FOR TODAY'S CLASSROOM

Prowise interactive flat panels offer the most advanced set of features which combine to maximize functionality, safety, and value in the classroom.

- **Superior built-in speakers ensure rich audio can be heard in all corners of the classroom**
- **Prowise Reflect enables wireless content sharing with up to four teacher or student devices**
- **Multiple panel inputs and intelligent switching simplifies integration requirements**

## THE CLOUD SETS YOU FREE

The industry move towards a software subscription model has been a negative experience. IT Managers across the country are now plagued with quarterly updates and software deployments, for very little educational gain. With Prowise Presenter cloud-based software, these challenges and issues are removed.

- **A cloud-based solution removes the need for IT involvement and provides a tool that can be accessed from any internet-enabled device**
- **A "pro account" license for Prowise Presenter will be provided to every teacher**
- **With unlimited cloud storage, teachers and students can store and retrieve content without hassle**
- **All data stored in the cloud is on US soil in compliance with leading certification and privacy standards**

## STUDENT ENGAGEMENT THROUGH DEVICES

iPads, Chromebooks, laptops, and smart phones are seeing their way into today's classroom at an exponential rate. Prowise ProConnect software easily connects and integrates these devices right into the learning environment.

- **Any internet-enabled student device can participate in collaborative, assessment or game-based activities**
- **This level of integration and interaction enhances the value of the student device and provides a great platform between the classroom display and the students**

## QUALITY AND REASSURANCE WITH A 5-YEAR WARRANTY

The standard warranty for interactive technology was set years ago by the major interactive whiteboard companies. However, we believe the move to interactive flat panels should warrant better coverage and better value. Prowise has set the new bar for safety, security and quality technology.

- **Prowise is committed to safety and security, resulting in products that are highly durable, with special safety and security features currently unmatched in the market**
- **Schools can enjoy complete piece of mind and reassurance that their technology investment is sound**

## WHY ELB?

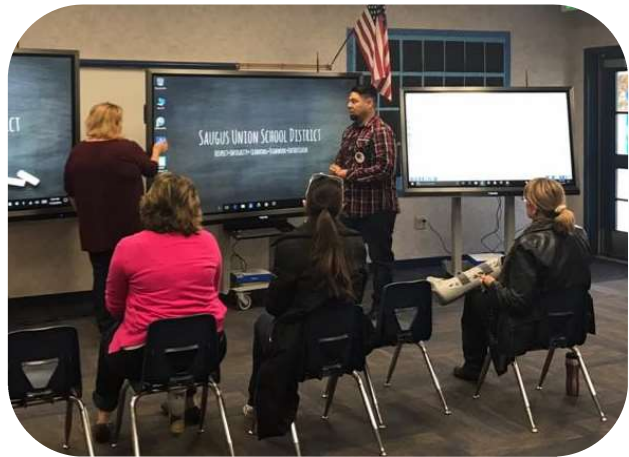
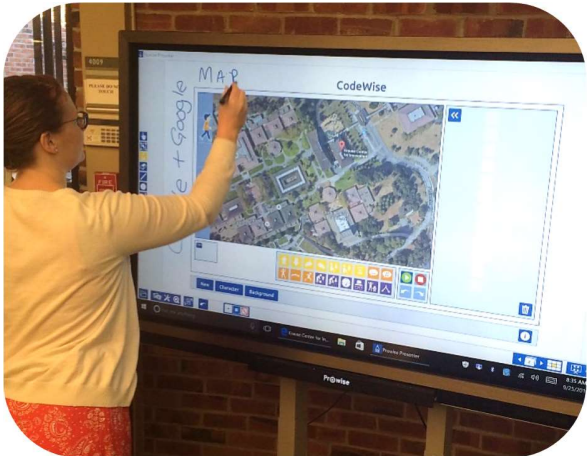
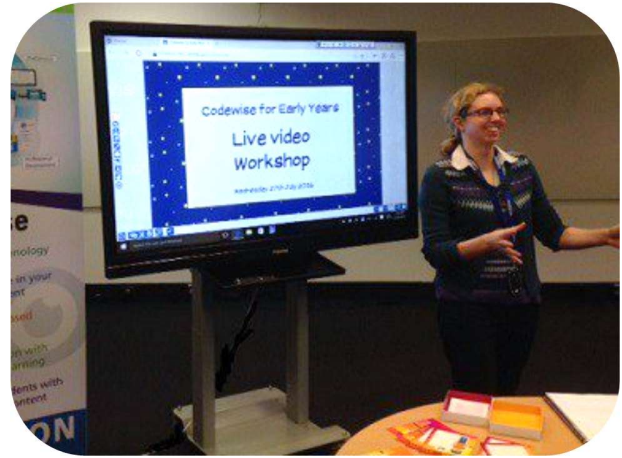

## LOCALIZED SUPPORT FROM EXPERIENCED EDUCATION CONSULTANTS

ELB has always recognized the importance of having Educators speak to Educators. As a result, our education “sales team” has always been made up of classroom trained teachers who advise, and consult based on their own personal experiences. These are our Education Consultants, and they:

- **Have relevant experience with technology rollouts of all sizes**
- **Build trusted relationships through a consultative approach within all levels of the school or district**
- **Own the sales cycle from the initial evaluation to the delivery of professional development and training**
- **Are local and can provide an unsurpassed level of support and expertise to schools and districts**

## MANY LESSONS LEARNED

Throughout our over 30 years of history, ELB has witnessed many successful, and in some cases, unsuccessful attempts at education technology integration. These lessons now form the core strategy by which our teams embrace and deliver service to our customers. The key components include:

- **Solution Selling – Deliver solutions which offer real value for money, don't just sell “products”**
- **Quality Products – Offer our education customers technologies which are innovative, have industry-leading designs, and an unmatched warranty**
- **Professional Development – Ensure all our education customers are supported by certified teachers who provide an exceptional level of training, professional development, and customer service**

## A PROVEN TRACK RECORD

One of our most recent large bid awards came from the Saugus Union School District in Santa Clarita, CA. After a two-year evaluation process, the decision was made and ALL classrooms in ALL District schools were outfitted with Prowise interactive flat panels, mobile lift systems and PC modules by the end of November 2016. All 425 systems were delivered, installed, and commissioned by ELB within just a few short months.

*“The growth of technology in our classrooms has allowed us to change the way we teach and the way we ensure the growth of the entire District, from teachers to students,” said Dr. Joan Lucid, Superintendent of Saugus Union School District. “Every student in every classroom in all of our schools will benefit from Prowise technology.”*

For the six months that followed installation, ELB Education Consultants worked closely with District TOSAs (teachers on special assignment) to create and deliver a customized District-wide training program which to this day has ensured the successful integration of Prowise hardware and software across schools.

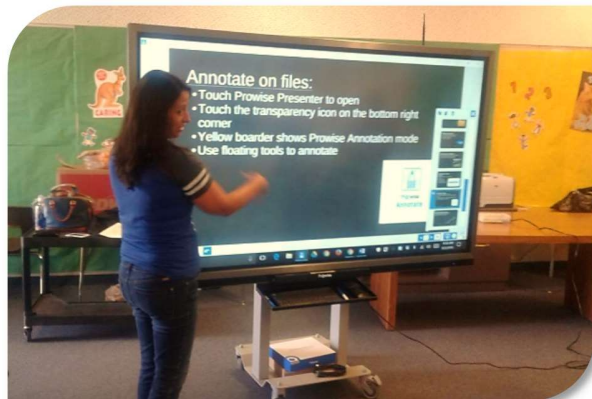

# Company Overview

---



**ELB**

CREATE.  
COMMUNICATE.  
COLLABORATE.

---

## BACKGROUND

ELB US Inc. (“ELB”) is one of the world’s leading providers of education technology and furniture solutions. For more than 30 years, we have successfully executed over 125,000 projects for a variety of clients across a diverse range of industries. We have been a key supplier and partner to thousands of corporate, government and education customers across the United States, Australia, and Canada.



ELB has established the knowledge, methodologies, and systems to deliver state-of-the-art solutions that typically exceed client expectations. Through a combination of organic growth and acquisition, we have grown significantly over the years, yet continue to provide a level of service and support currently unmatched in the industry. Our products, services, and support facilities are diverse and comprehensive, ensuring we can meet the varied needs of our clients any time, any place, and in any way. We have the experience, scale, commitment, support, and track record of success to offer our customers a risk-free solution.

- **Experience** – We have been successfully supplying audio visual, visual collaboration and unified communications solutions to enterprise, government and education clients for over three decades. Our certified engineers, designers, programmers, project managers, CAD drawers, installers, and service technicians are backed by an extensive in-house project tracking system managing all aspects of the customer experience.
- **Scale** – We are a financially stable, debt-free business with over \$100 million annual turnover. We have both the scale and resources to provide our clients with a comprehensive, peace-of-mind solution.
- **Commitment** – Nearly all of our 15 offices and 3 major warehouses are located in company-owned and operated buildings– demonstrating a commitment to the markets in which we serve.
- **Support** – We offer comprehensive technical support to all our clients through our National Service and Support Help Desk, staffed by qualified, full-time audio visual and video conferencing engineers. At the local level, our technical specialists offer post-project operational support, as well support for the ongoing maintenance of technology assets.
- **Success** – Headquartered in Pleasanton, CA, with a regional office located in Cypress, CA, we have become a trusted and reliable audio visual provider to many well-known global companies as well as colleges and K12 school districts. We have a proven track record of success and an established infrastructure, management base and staffing level to support projects big and small.

---

## MISSION AND PURPOSE

**Mission: We strive to provide world class integrated solutions and services to the enterprise, government and education sectors.**

### **We CREATE.**

We create the highest quality solutions for all our clients in the education, enterprise and government sectors. We **work with many of the world's most popular and leading-edge suppliers to provide the best range of options for creating the most ideal collaborative environments.** We also draw on the collective expertise of our diverse team to offer fresh ideas and innovative approaches.

### **We COMMUNICATE.**

With offices in the United States, Australia, and Canada, we are unique in our industry— **we possess the skills, knowledge and infrastructure to support our customers globally, regionally, and locally.** Our network and capabilities are global, yet our focus and track-record in delivering superior results, one customer and one location at a time, is unsurpassed.

### **We COLLABORATE.**

At the core of our business we understand that every customer is unique. **What differentiates ELB is our end-to-end collaborative and comprehensive approach— from initial consultation right through to design, installation, training and maintenance.** Our goal is to partner with you to discover and implement new ways to work, learn and collaborate more effectively.

## HISTORY

ELB has a long and successful history providing leading-edge collaboration solutions to our customers around the world. Since our establishment in 1986, we have successfully opened 15 branch offices and three major warehouse facilities across four countries. We have also acquired and incorporated several businesses to continually expand and augment our product and service line offerings.

Today, we are pleased to be an “all-in-one provider” of products and services to support all stages of the technology lifecycle: from initial consultation and design to implementation, training, and ongoing service and support. ELB continues to grow, and future expansion, particularly within the continental United States, is imminent.

ELB has been providing innovative technology and furniture solutions to the education community since 1986. We count thousands of schools, learning centers, training facilities, and other educational facilities across the world as our customers.

An overview of ELB’s history is outlined in the timeline below:

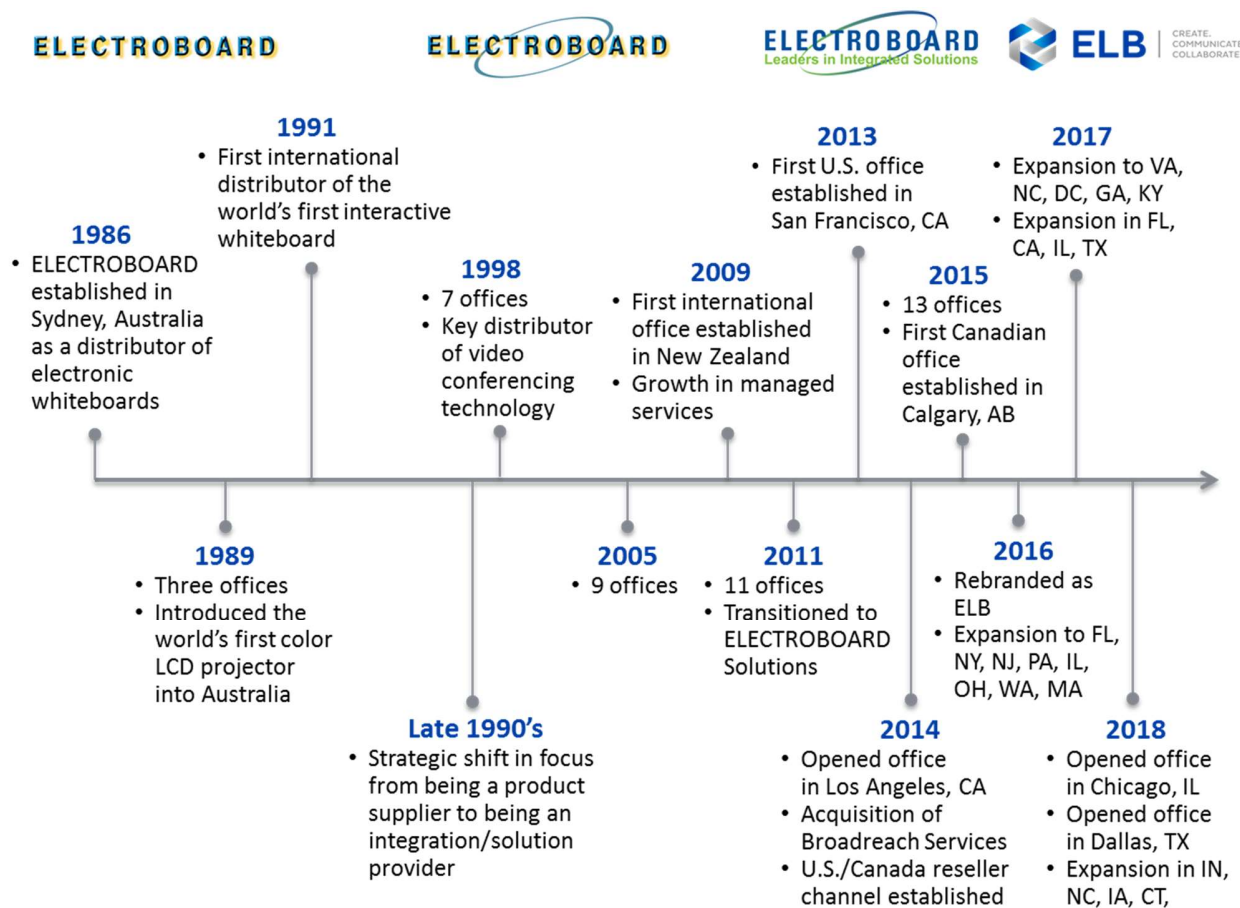



## U.S. OPERATIONS

ELB officially commenced operations in the United States in 2012 and since that time we have significantly grown our national footprint. The majority of this growth has been propelled by an increasing demand for our education solutions and services, as well as Preferred Supplier Agreements with several well-known global technology companies. While we continue to expand nationally, our national service center and product warehouse remains located in Pleasanton, CA. To date, our U.S. operations includes:

- 95+ employees
- 20 locations with more to come
- Approx. 20,000 sq. ft. of warehouse space
- Eight service and installation vans
- 12 fleet vehicles
- 25 Education Consultants, 10 Project Managers, 8 System Engineers, 3 Programmers, 8 Installers, 10+ subcontracted installers
- Services provided include sales, engineering and design, installation, project management, documentation and training, technical support, marketing, human resources, finance, purchasing, shipping and receiving, and warehousing.



## LOCAL OPERATIONS

ELB has established a **major regional office in Cypress, CA**. Located **just minutes from Magnolia Public Schools**, our local office can provide the full scope of professional audio-visual sales and support services. Our Cypress location also serves as the **technical support hub** for our entire national company, as well as a secondary **warehouse facility**. This means that we will be able to provide prompt sales and exceptional technical support services to MPS whenever required and can hand-deliver products to all schools in a very short period of time.

## SCHOOL MANAGEMENT APPROACH

When working with our large school district customers, we take a multi-tiered approach to maximize the benefits and ensure a positive, value-added relationship. We envision a similar partnership with Magnolia Public Schools, where collaboration at each school and project level will be key for success.

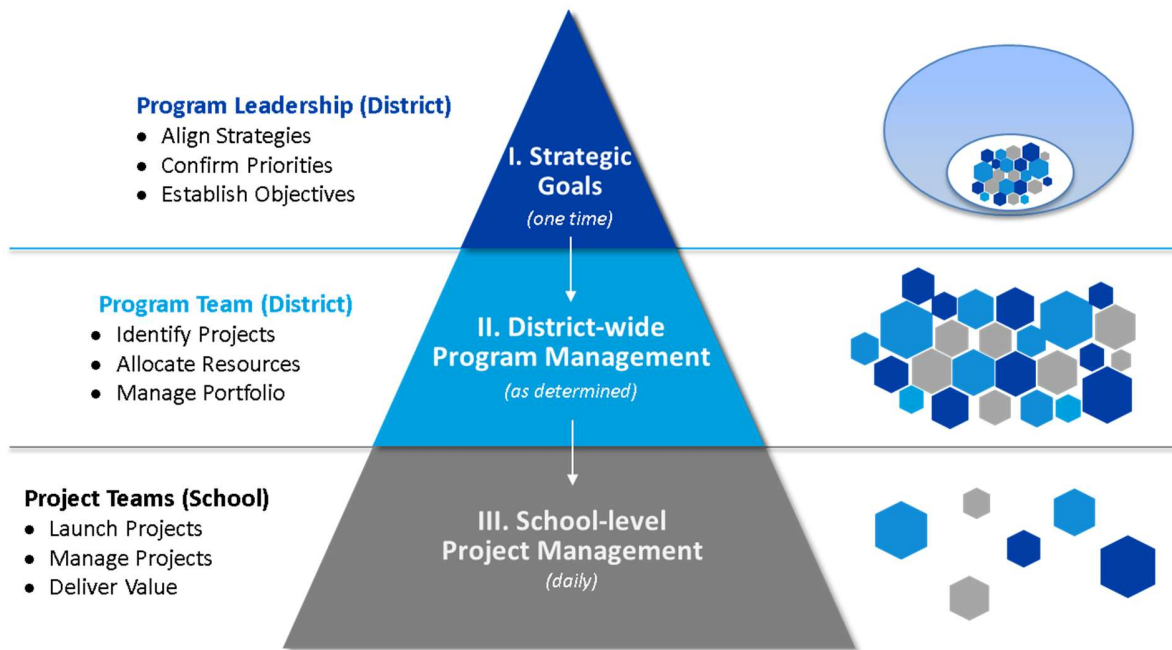

### PROGRAM (SCHOOL) MANAGEMENT

It is ELB's desire to become a trusted, knowledgeable, quality advisor not only to school personnel, but also to the principals, teachers and students within each school. It is our goal to engage at both the District and school levels to understand needs, expectations, and constraints so that the value we provide reaches far beyond just the delivery of goods and services. In that way, we seek to support initiatives, processes, and goals at multiple levels and across multiple locations. We call this our "program" or holistic management approach.



While the majority of implementation projects are likely to occur in a school setting, we do see value in offering MPS any or all of the following advisory and management services:

- *Review of existing systems and environments* – identification and evaluation of current technology including warranty coverage
- *Advisement* – recommendations on the retirement or replacement of out-of-warranty, end of life, and outdated technology
- *Scope management* – which locations, what products/services, what efficiencies can be achieved in people, processes, or technology
- *Procurement management* – where and how to deliver products, how to realize cost savings

- *Implementation management* – who will provide installation, commissioning, training, service
- *Schedule/time management* – Timing and resource allocation
- *Cost management* – how to mitigate cost over-runs, how to reduce product/service costs
- *Quality management* – how, when, where to review product/service quality and ensure continuous improvement
- *Communication management* – what, when, how to communicate overall status to MPS school personnel (e.g. pending, in-flight, completed projects)
- *Risk management* – how, who, when to mitigate or resolve issues of risk
- *Financial management* – who, where, what is being purchased

We are very experienced in supporting Districts with the evaluation and subsequent roll-out of District-wide technology. In general, our first step is to formally meet with the appropriate District-level personnel to confirm the District’s current and future technology plans, desires, needs and expectations. We will then work collaboratively to ensure our proposed plan for this program fully aligns with the District and to solidify the operational requirements that will ensure success. More details about this important first step, including the activities that are proposed to take place, can be found on the Implementation Roadmap that follows. Once the goals are clear, expectations are set and operational requirements are confirmed, we will then proceed to start engaging at the school level.

## PROJECT (SCHOOL) MANAGEMENT

### Role of the Education Consultant

To best support MPS, a local ELB Education Consultant will be assigned to perform day-to-day customer management. The role of the MPS EC is to work closely with each school to assess technology needs, to support the evaluation and purchase of technology, to work with internal ELB teams to successfully execute any large-scale roll-outs or integration projects, and to provide the necessary localized training and professional development support to ensure adoption success. The ELB EC will also be the key point person for any technical or warranty-related issues and escalate the need for any additional support to the ELB Technical Service team.

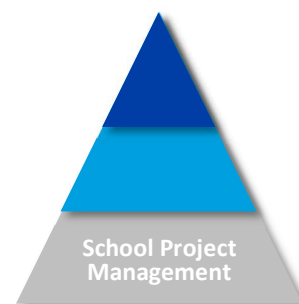

### Project Management Methodology

Project management is a fundamental component of solution delivery at ELB. For every school technology project or implementation, we use several internal systems and communication methods, including several mobile apps, to ensure timely completion of activities and tasks, updates to project schedules, notification of any risks or issues, and accurate reporting.

If there are project delays or difficulties, regular project management meetings and a review of the project timeline can be done. ELB Project Managers use Microsoft Project as well as our comprehensive internal project tracking system (“PTS”) to ensure all projects run smoothly.

Our delivery process for any classroom audio visual project that requires engineering, installation, white-glove delivery, technical integration or specialized logistics, will include a sequence of coordinated activities. An ELB Project Manager and Education Consultant will be assigned to the District and will be responsible for the successful execution of this upgrade program.

## TRAINING AND PROFESSIONAL DEVELOPMENT

### ELB UNIVERSITY (ELBU)

All of our interactive solutions are fully supported by a team of Education Consultants as part of our ELB University (ELBU) offering. These classroom-trained teachers are experts in incorporating key pedagogies and understand the steps to a successful classroom implementation. All of our learning modules are designed and delivered by our EC's and can be tailored to meet the educational goals of Magnolia Public Schools.



ELBU courses are not just about using education technology- they are about using the technology to promote quality teaching and to achieve curriculum outcomes effectively. These courses include hands-on activities to allow participants to master the skills covered and receive immediate feedback and support. All courses:

- Are delivered by teachers who have extensive experience using ICT in the classroom
- Assist teachers at all levels to use technology effectively within a pedagogical framework
- Include hands-on technology experiences
- Give practical ideas for teaching and learning
- Discuss real classroom scenarios and practical ideas
- Are designed by certified educators for educators
- Can be customized to suit your educational setting, learning needs or curriculum requirements

### EDUCATION CONTENT

At ELB, we are proud to offer a wide range of foundational, transitional and transformative professional development options designed to help teachers gradually integrate new technologies into their everyday teaching practices.

- **Foundational PD** courses focus primarily on the acquisition of basic technical and functional skills required to successfully operate any new piece of technology.
- **Transitional PD** focuses on proven pedagogical strategies that are applicable across all grade levels and subject areas. This usually involves the sharing of specific classroom examples of how our solutions can be used most effectively to address key pedagogical initiatives.
- **Transformative PD** brings together the concepts acquired during foundational and transitional PD to affect a deep and lasting shift in teacher practice. This can involve the integration of other technologies, the facilitation of content creation seminars, the hosting of professional learning communities, etc.

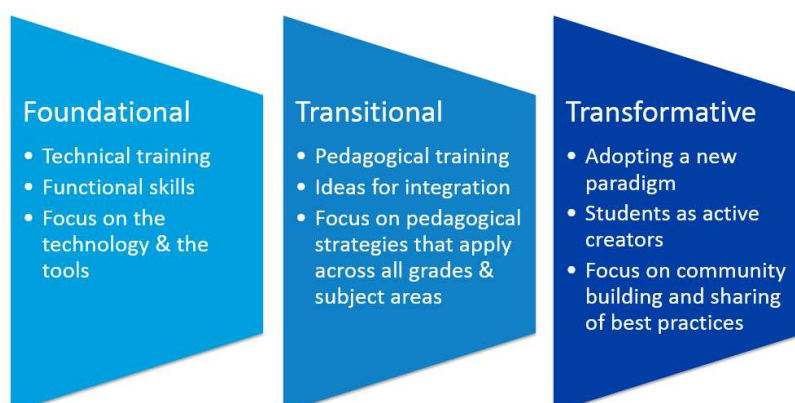

# Product Quotes, Product Details and Sample Installation schedule



---







**ELB**

CREATE.  
COMMUNICATE.  
COLLABORATE.

PROWISE PANEL BUNDLES AND REQUESTED QUOTATIONS



	Description	MPS Pricing
<p><b>65" Touchscreen iPro Tilt Lift Bundle</b></p> 	<p><b>PROWISE 65" Touchscreen + iPro Tilt Bundle</b></p> <ul style="list-style-type: none"> <li>* Prowise 65" Touchscreen</li> <li>* Integrated PC Module</li> <li>* Prowise MOVE</li> <li>* iPro Tilt Lift System</li> <li>* Prowrite Ink</li> <li>* Dolby Audio Soundbar and 2.1</li> <li>* Four Wide Area Microphones</li> <li>* 5 Year Onsite Warranty</li> <li>* <b>Price is per bundle and Includes Freight, Onsite Delivery, Set Up and Sales Tax</b></li> </ul>	<p><b>\$5,365</b></p>
<p><b>65" Touchscreen + Mobile Up and Down Lift</b></p> 	<p><b>PROWISE 65" Touchscreen + Mobile Lift Bundle</b></p> <ul style="list-style-type: none"> <li>* Prowise 65" Touchscreen</li> <li>* Integrated PC Module</li> <li>* Prowise MOVE</li> <li>* Mobile Lift System</li> <li>* Prowrite Ink</li> <li>* Dolby Audio Soundbar and 2.1</li> <li>* Four Wide Area Microphones</li> <li>* 5 Year Onsite Warranty</li> <li>* <b>Price is per bundle Includes Freight, Onsite Delivery, Set up and Sales Tax</b></li> </ul> <p>*NOTE: This stand will be changing model names to the iPro Mobile Lift beginning in early to mid Spring 2019. MPS bid pricing will NOT be affected.</p>	<p><b>\$5,255</b></p>
<p><b>65" Touchscreen +iPro Adjustable Wall Mount Bundle</b></p> 	<p><b>PROWISE 65" Touchscreen + iPro Height Adjustable Wall Mounted Lift Bundle</b></p> <ul style="list-style-type: none"> <li>* Prowise 65" Touchscreen</li> <li>* Integrated PC Module</li> <li>* Prowise MOVE</li> <li>* iPro Height Adjustable Wall Mount Lift System</li> <li>* Prowrite Ink</li> <li>* Dolby Audio Soundbar and 2.1</li> <li>* Four Wide Area Microphones</li> <li>* 5 Year Onsite Warranty (Panel, Lift, PC Module)</li> <li>* <b>Price is per bundle and Includes Freight, Onsite Delivery, Set Up and Sales Tax</b></li> </ul>	<p><b>\$6,021</b></p>



<p><b>65" Touchscreen Fixed Wall Mount</b></p> 	<ul style="list-style-type: none"> <li>* Prowise 65" Touchscreen</li> <li>* Integrated PC Module</li> <li>* Prowise MOVE</li> <li>* Prowrite Ink</li> <li>* Dolby Audio Soundbar and 2.1</li> <li>* Four Wide Area Microphones</li> <li>* 5 Year Onsite Warranty</li> <li>* <b>Price is per panel and Includes Freight, Onsite Delivery, and Sales Tax</b></li> </ul>	<p><b>\$4,160</b></p>
<p><b>75" Touchscreen Mobile Height Adjustable Lift Bundle</b></p> 	<p><b>PROWISE ProLine 75" Ultra HD LED Multi-touchscreen</b></p> <ul style="list-style-type: none"> <li>* Prowise 75" Touchscreen</li> <li>* Integrated PC Module</li> <li>* Prowise MOVE</li> <li>* DUO Up and Down Mobile Lift System</li> <li>* Prowrite Ink</li> <li>* Dolby Audio Soundbar and 2.1</li> <li>* Four Wide Area Microphones</li> <li>* 5 Year Onsite Warranty</li> <li>* <b>Price is per bundle and Includes Freight, Onsite Delivery, Set Up and Sales Tax</b></li> </ul> <p>*NOTE: This stand will be changing model names to the iPro Mobile Lift beginning in early to mid Spring 2019. MPS bid pricing will NOT be affected.</p>	<p><b>\$6,350</b></p>

<p><b>75" Touchscreen Height Adjustable Wall Mount Bundle</b></p> 	<p><b>PROWISE 75" Touchscreen + iPro Height Adjustable Wall Mounted Lift Bundle</b></p> <ul style="list-style-type: none"> <li>* Prowise 75" Touchscreen</li> <li>* Integrated PC Module</li> <li>* Prowise MOVE</li> <li>* iPro Height Adjustable Wall Mount Lift System</li> <li>* Prowrite Ink</li> <li>* Dolby Audio Soundbar and 2.1</li> <li>* Four Wide Area Microphones</li> <li>* 5 Year Onsite Warranty</li> <li>* <b>Price is per bundle and Includes Freight, Onsite Delivery, Installation and Sales Tax</b></li> </ul>	<p><b>\$7,116</b></p>
<p><b>75" Touchscreen Fixed Wall Mount</b></p> 	<p>Prowise 65" Touchscreen</p> <ul style="list-style-type: none"> <li>* Integrated PC Module</li> <li>* Prowise MOVE</li> <li>* Prowrite Ink</li> <li>* Dolby Audio Soundbar and 2.1</li> <li>* Four Wide Area Microphones</li> <li>* 5 Year Onsite Warranty</li> <li>* <b>Price is per panel and Includes Freight, Onsite Delivery, and Sales Tax</b></li> </ul>	<p><b>\$4,830</b></p>
<p><b>Installation of Panel on Height Adjustable Wall Mount (only applies to mounting Prowise panels)</b></p>	<p><b>Price Includes iPro Height Adjustable Lift System and Sales Tax</b></p>	<p><b>\$1,500</b></p>
<p><b>Installation of Panel on Fixed Wall Mount (only applies to mounting of Prowise panels)</b></p>	<p><b>Price includes fixed wall mount and Sales Tax</b></p>	<p><b>\$500</b></p>



**PROWISE PRODUCT DESCRIPTION**

<p><b>iPro Height Adjustable Wall Mount</b></p> 	<p>Prowise have engineered a motorized, height-adjustable wall mount with floor support. This lift system supports all sizes of Prowise panels and when used with a built-in PC module, requires only one power cable for ease of installation. The panel can be raised/lowered easily using the two electronic buttons located on the side of the mount or onscreen via Prowise Central. The lift is also equipped with an advanced safety system which continuously monitors secure operation. When the lift meets resistance, it immediately stops moving. This lift and all lifts include an onsite 5 year warranty.</p>
<p><b>Height Adjustable Lift System</b></p> 	<p>Our height-adjustable, motorized mobile display stand supports all sizes of Prowise panel. Only one power cable is required for operation, simplifying use and improving safety. The panel can be easily raised/lowered using the two-button electronic remote attached to the stand. The lift is also equipped with an advanced safety system which continuously monitors secure operation. When the lift meets resistance, it immediately stops moving. This lift and all lifts include a 5 year warranty.</p> <p>*NOTE: This stand will be changing model names to the iPro Mobile Lift beginning in early to mid Spring 2019. MPS bid pricing will NOT be affected.</p>
<p><b>iPro Tilt Lift System</b></p> 	<p>Our most innovative lift system supports whole class instruction, small group, and table mode with the press of a button or onscreen via Prowise Central. Supporting up to a 65" Prowise Touchscreen panels, our height-adjustable, motorized stand can be moved around the classroom and titled at any angle from vertical to horizontal. Only one power cable for both panel and stand is required for operation, simplifying use and improving safety. The panel can be easily raised/lowered and tilted forward/backward using the four-button electronic remote attached to the lift. The lift is also equipped with an advanced safety system which continuously monitors secure operation. When the lift meets resistance, it immediately stops moving. This lift and all lifts include a 5 year warranty.</p>

<p><b>Prowise Touchscreen</b></p> 	<p>With Prowise Touchscreen you can effortlessly enjoy the world's most advanced interactive experience. The very highest quality materials combine with the hardware and software developed by Prowise to give unique education and presentation possibilities. The low energy consumption, the revolutionary price and the standard 5 year onsite warranty ensure an unprecedentedly low total cost of ownership.</p> <ul style="list-style-type: none"> <li>* 4K Ultra HD IPS Anti-Glare Finish</li> <li>* Fully Integrated 2.1 Dolby Audio Sound Bar</li> <li>* Four Built-In Wide Area Microphones</li> <li>* Prowrite Ink with Two Ergonomic Pens</li> <li>* Prowise Central that includes Prowise Pronote,</li> <li>* Prowise Reflect Screen Mirroring</li> </ul>
<p><b>PC Module</b></p> 	<p>Prowise PC Modules are equipped with a powerful Intel Processor, and Ultra HD video card and a super fast SSD drive to ensure you get the very best out of your Prowise Touchscreen.</p> <ul style="list-style-type: none"> <li>* Windows 10 Enterprise OS Included</li> <li>* Intel Core i5 7200u</li> <li>* Intel HD Graphics 620</li> <li>* 8 GB, DDR4L 2133MhZ RAM</li> <li>* 128 GB SSD Sata 3.0</li> <li>* Wireless and Wired Connectivity</li> <li>* 1xUSB-C, 2xUSB 3.0, 2xUSB 2.0, HPJ, Microphone, HDMI out</li> <li>* 5 Year Warranty</li> </ul>

# Prowise Presenter

Discover a world of free educational content

Offers both teacher and students endless possibilities: create lessons or essays, work with innovative tools and create interactivity in your classes for a variety of teaching situations. Presenter has been optimised for our touchscreens and devices, but can always be used on other devices.

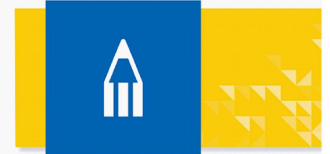

**100%**  **FREE**

Prowise Presenter is completely free for everyone!

- one account
- completely free
- for new and existing users
- all the unique benefits of Prowise Presenter
- no small print



## Over 200 tools

The huge collection of tools, specially developed for all ages and disciplines, offers a world of instruction and practise material for your lesson. Drop ready-made tools into your lesson, or adjust them to the level of your class.

 *Touch table tools combine learning, fun and collaboration.*

## Annotate

Integrate current events into your lesson. Take notes on websites and directly add the screenshots to your presentation.



[More info](#)

## ProConnect

First-class interaction

- Share screens between device and touchscreen
- Monitor your students' work live
- Take a vote among all students in class
- Collect student work
- Challenge each other in educational games
- Create a quiz at any desired level

## Community

Share your lessons at school, trust/LA or national level. This way, you can use your follow teachers' lessons for inspiration. We will also post ready-made lessons to the community regularly.

## REFLECT

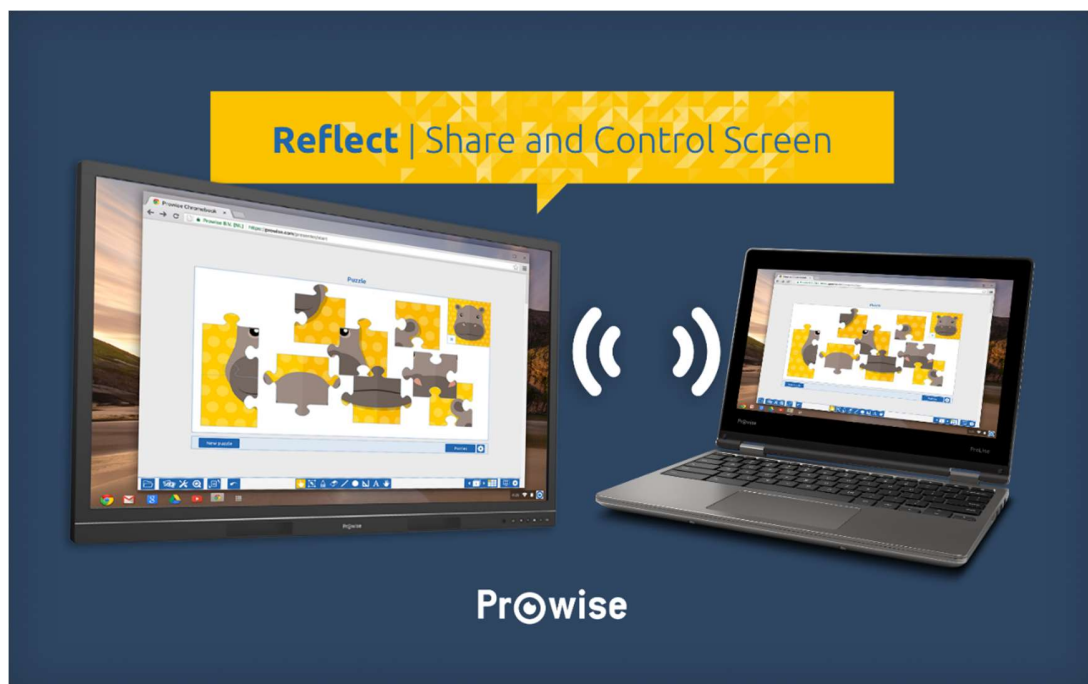

Through ProWise Reflect, up to four devices can be displayed on the panel at one time. This simple feature removes the need for additional hardware and cables enabling teacher and/or student displays to be viewable by everyone. Students are able to showcase work samples, compare strategies for problem solving, or anything else they need to do, all while connected to the school network. Certain devices will have this functionality built-in natively (Windows & Mac), while others require a simple download of a free app. When sharing a Windows or Mac computer, touch control is also enabled through the Reflect connection further enhancing the user experience without the hassle.

# SAMPLE INSTALLATION SCHEDULE FOR MOBILE UNITS

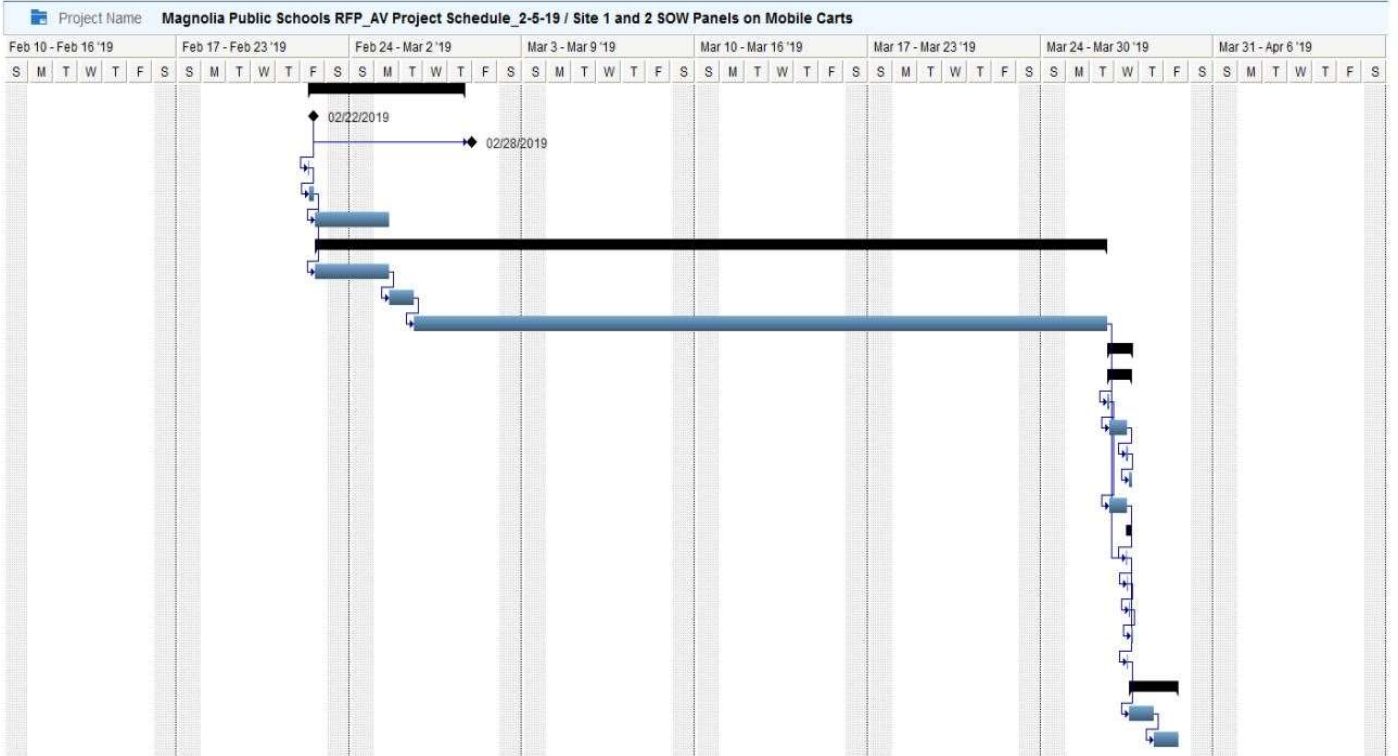



# Experience and Qualifications of Staff

---



**ELB**

CREATE.  
COMMUNICATE.  
COLLABORATE.

---

## OUR COMMITMENT TO EDUCATION

ELB is committed to education. We believe strongly in the need to raise up students who will be competent, capable and thriving members of our society in years to come. We also believe strongly in the need to provide today's learners with access to technology, and today's educators with the training and professional development support they need for success. While we are committed to providing our education customers with safe, quality education technology products, we are equally committed to investing in the resources, professional development programs and training that are required for their success.



Every year, ELB delivers a significant amount of training and professional development to the education community. On a daily basis, we provide one-on-one technology training to teachers across the country. Throughout the year, we host national education technology conferences, video conferencing events, and lesson-development workshops for educators and students. These are funded and organized by ELB and offered completely free of charge. We also task our education staff with developing curriculum-based resources which are offered free online. All combined, we believe the investments we make in this area today, will make a lasting impression on the society of tomorrow.

---

### ELB EDUCATION

Should ELB be invited to offer MPS schools audio visual products and services, all training and support will be provided through our ELB Education division. **ELB Education** provides innovative technology products, services and solutions to the education sector. This includes assisting schools—from early years learning centers to colleges and universities— to enhance their educational outcomes through the use of technology, supporting student learning, and the professional development of teachers.



Through ELB Education, teachers have access to some of the world's leading education technology products, as well as a large number of free curriculum resources, innovative programs and events, national and international support networks, educational conferences and professional development courses.

To ensure specialized support and insight, all services are provided by experienced Education Consultants ("EC's"). ELB Education Consultants are trained and certified classroom teachers who work directly with schools to understand their needs, recommend solutions and support the adoption and effective use of technology in the classroom. We currently have EC's located throughout the United States to provide service and support to all areas of the country.



---

## EXPERIENCED EDUCATION CONSULTANTS

ELB has always recognized the importance of having Educators speak to Educators. As a result, our education team has always been made up of classroom trained and certified teachers who advise and consult based on their own personal experiences. Our Education Consultants:

- Have current knowledge of local, regional and national education trends
- Have relevant experience with technology rollouts of all sizes
- Have various education technology distinctions including those from Microsoft, SMART, Google
- Build trusted relationships through a consultative approach within all levels all MPS schools
- Provide a wide range of services from the initial evaluation to the delivery of professional development and training
- Are local and can provide an unsurpassed level of support and expertise to schools and districts



---

## MANY LESSONS LEARNED

Throughout our 30 years of history, ELB has witnessed many successful, and in some cases, unsuccessful attempts at education technology integration. These lessons now form the core strategy by which our teams embrace and deliver service to our customers. The key components include:

- **Solution Selling** – Deliver solutions which offer real value for money, don't just sell "products"
- **Quality Products** – Offer our education customers technologies which are innovative, have industry-leading designs, and an unmatched warranty
- **Professional Development** – Ensure all our education customers are supported by certified teachers who provide an exceptional level of professional development, and customer service
- **Local Support** – Maintain "feet on the street", ensuring timely service and support in key jurisdictions

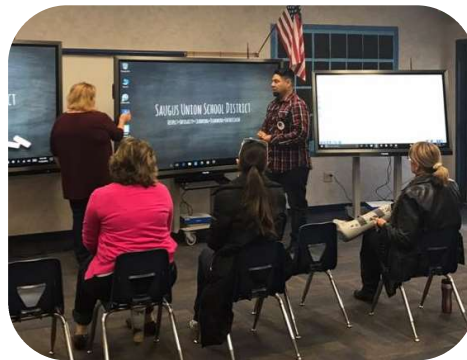

## EXPERIENCED AND DEDICATED MPS-ELB TEAM

### TEAM STRUCTURE AND SUPPORT

The following diagram outlines the proposed structure and key responsibilities of the ELB Project Team for the delivery of audio visual products and services to Magnolia Public Schools.

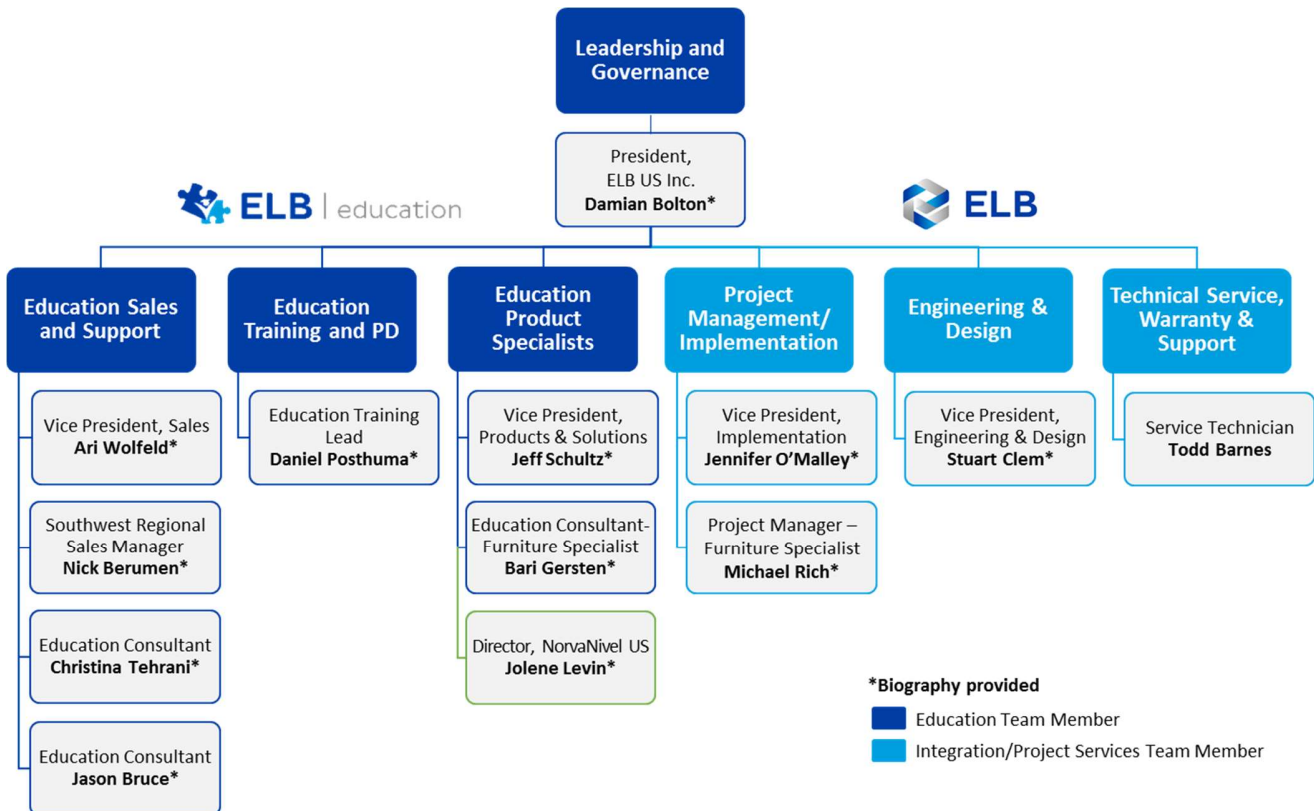

---

## KEY PERSONNEL BIOGRAPHIES

### **Christina Tehrani**

#### *Education Consultant*

Christina has been working in education for over 8 years. Since joining ELB over two years ago, she has been instrumental in supporting numerous schools in the successful integration of new technology. Most notably, she was a lead Education Consultant for the District-wide roll-out of Prowise interactive flat panels at the Saugus Union School District. Prior to joining the ELB Education team as an Education Consultant, she spent 6 years teaching high school English in Los Angeles and San Diego Counties. Previously, she also taught English Language Learners and led after school programs that focused solely on incorporating technology in the classroom. Christina has a California Single Subject Teaching Credential in English Language Arts from San Diego State University, a Master's in Education Technology and a BA in English from Azusa Pacific University. Her passion is in equipping students and teachers with engaging technology in order for them to access 21st Century Learning Skills in the most innovative and collaborative ways.



### **Jason Bruce**

#### *Education Consultant*

Jason has been in the education field for the past 13 years. He received his undergraduate degrees from UCLA, and earned his Masters of Education from Arizona State University. Jason also holds a California Multiple Subject Teaching Credential and an Early Childhood Teaching Certificate from the State of Utah. Jason has taught 3rd and 5th grades in California for two years and 3rd grade for six years in Utah. Jason was among the first to use SMART Boards and later became part of the technology committee for the Washington County School District in St. George, Utah. There he was mostly responsible for training teachers on SMART Notebook software. As an ELB Education Consultant, Jason now helps lead the Southern California Education Team training teachers, administrators, and district leaders best practices using Prowise interactive panels and Presenter cloud based software. Most notably, Jason was a lead Education Consultant for the District-wide roll-out of Prowise interactive flat panels at the Saugus Union School District.



---

## Daniel Posthuma

### *Education Consultant and Training Lead*

With over 10 years spent working in education, Daniel brings a wide variety of knowledge and experience to his role as an Education Consultant and Trainer. Since joining ELB, he has conducted trainings across Southern California, helping teachers effectively integrate new technology into their classrooms. As a former teacher himself, Daniel provides relevant and adaptable trainings that are designed to help teachers immediately begin implementing this technology into their lessons. Daniel received both his undergraduate and Single Subject Teaching Credential from Cal State Fullerton and prior to joining ELB, he taught for schools in Los Angeles and Orange Counties, as well as two years as a Title I tutor for the Orange County Dept. of Education, two years as an instructional technician at Saddleback College, and five years working directly with students in Special Education. His passion to see students become excited about learning has found its perfect match at ELB, where he is able to introduce classroom solutions that spark students' interest, and open them up to the world of possibilities that interactive, flexible learning spaces can provide.



## Nick Berumen

### *Western Regional Sales Manager*

Nick has been in sales and account management for over 15 years. For over 10 years, he has led and managed business development teams in the software and computer technology industry. This has included roles as Sales Director for DataForm Software and Sales Operations Manager at Reliable Computer. Through these experiences, Nick gained a superior understanding of the technology sales process and developed the skills necessary to deliver exceptional customer service. His history and track record of supporting many government as well as higher education technology implementations is testament to this fact. As a Sales Manager for ELB, Nick oversees all business development and sales activities in Southern California and helps mentor junior Account Managers. Ever the professional, Nick's passionate and customer-centric approach to business makes him a well-liked and well-respected colleague and advisor.



## Jeff Schultz

### *Vice President, Products and Solutions*

Jeff has been specializing in interactive technology for over 15 years and has been with ELB since April 2006. For nine of those years he worked in Australia in a variety of technology training and product management roles. Now based in California, Jeff is responsible for the strategic direction of our Prowise business. A specialist in interactive technologies, he understands the importance of professional development as a key component of a successful implementation. Prior to ELB, Jeff lived in Canada where he was a Training Team Lead for SMART Technologies and spent much of his time working and interacting with educators all across the United States to improve teaching and learning through the use of interactive technology.

Jeff has played a pivotal role in several very large and very successful roll-outs of interactive classroom technology. He has provided training, professional development and product advisory support for the delivery of numerous state, district and school-wide contracts across the United States, Canada and Australia. A graduate of DeVry University in Phoenix, AZ with a Bachelor of Science in Business Operations, Jeff demonstrates the perfect balance of knowledge, skill and past experience to ensure the success of any project he supports.



---

## **Ari Wolfeld**

### *Vice President Sales*

An industry expert in collaboration technology, Ari has enjoyed great success helping companies evaluate and implement enterprise-wide collaboration solutions. With over 6 years' experience in the video conferencing, unified communications, and interactive whiteboard market, he leverages technical knowledge to identify and meet client needs. Ari has extensive experience supporting the collaboration needs of the architecture, engineering and construction (AEC) industry. He has a certification in Lync Room System sales enabling him to work with his clients to bring the Microsoft Lync user experience into the conference room. Partnering with clients as a trusted resource is Ari's main goal. As the North American Sales Manager, Ari leads all of the Business Development and Education Consultant teams, fostering a culture of customer service excellence and superior solution delivery.



## **Damian Bolton**

### *President, ELB US Inc.*

Damian has over 20 years of international audio visual integration, visual collaboration and unified communications experience. He has been with ELB for over 15 years, working initially in Sydney, Australia and most recently founding the company's US operations. Damian also previously worked for over 8 years in a variety of diverse and challenging roles at SMART Technologies in Calgary, Canada where he developed strong skills in training, product management and strategy.

Damian has been leading teams in the effective roll-out and integration of classroom technology for over 15 years. This has included providing support for the delivery of numerous state, district and school contracts across the United States, Canada and Australia. His understanding and awareness of not only the benefits of such implementations, but also the common hurdles and challenges, has made him a sought-out and respected industry leader.

An alumnus of the Stanford Graduate School of Business, Damian is passionate about technology and ELB's role as an innovator within the industry. Damian understands that customers are the core of ELB's business and acknowledges this by setting and supporting a customer-centric culture within his team. This culture thrives on excellent client service, efficient solutions delivery and provision of ongoing customer care.



## **Jennifer O'Malley, CTS, PMP**

### *Vice President Implementation*

Jennifer has over 15 years of project management and general management experience and has worked in the audio-visual industry for 8 years. She holds the PMP (Project Management Professional) and CTS (Certified Technology Specialist) certifications from the Project Management Institute and InfoComm, respectively. Prior to the audio visual industry, Jennifer was a Project Manager in the global petrochemical, aerospace, and financial services industries, managing multi-million dollar projects from start to finish, engaging and communicating with all levels of stakeholders. As Operations Manager for ELB, Jennifer oversees all aspects of audio visual and unified communications systems integration projects. This includes managing and mentoring project managers to ensure timely and successful delivery of all projects within the pre-determined budget.



# Past Experience, Performance and References

---



**ELB**

CREATE.  
COMMUNICATE.  
COLLABORATE.

## SAUGUS USD – FULL TECHNOLOGY ROLL-OUT

Saugus Union School District (SUSD) is located in the Santa Clarita in Northern Los Angeles County and currently operates fifteen K-6 schools as well as preschool programs across sixteen campuses.



ELB has supplied, installed, and continues to support the implementations of approximately 500 (five hundred) 65” or 84” **Prowise Pro Line interactive panels mounted on Prowise lift systems**, along with Prowise Presenter software to SUSD schools. As a **district-wide rollout**, the SUSD wanted to improve student learning outcomes with the application of full classroom technology solutions. ELB not only successfully executed the entire roll-out of new technology solutions, but also supported the District with training and professional development by providing two (2) educational consultants onsite twice a week over the course of the 2016-2017 school year. This support helped ensure teaching and learning was more effective and rewarding at Saugus.

For more information on this technology implementation, please refer to the following news stories:

<http://www.hometownstation.com/santa-clarita-news/education/saugus-union-school-district/saugus-union-to-unveil-state-of-the-art-classrooms-176059>

<http://scvnews.com/2016/09/22/interactive-touchscreen-computers-come-to-the-saugus-union-school-district/>

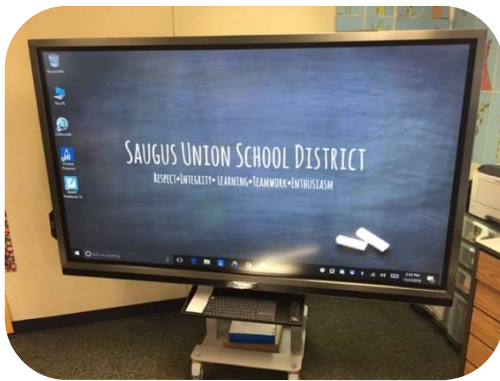

## FACEBOOK – GLOBAL HEAD OFFICE

ELB provided all of the audio visual and video collaboration hardware as well as integration services for **Facebook's new Global Head Office (MPK20)** in Menlo Park, California.



The sprawling 430,000-square-foot facility, designed by world-famous architect Frank Gehry, is spread over 22 acres, is LEED-certified and boasts a 9-acre green roof, as well as underground parking lot. The large, open floor plan building, which now houses 2,300 employees, includes over 300 conference rooms ranging in size from small huddle rooms to large boardrooms. It also includes five Executive Briefing Centers. Facebook's goal for MPK20 is to facilitate collaboration, creativity, and provide a new level of workspace transparency.

By leveraging our expert project management capabilities, a superior supply chain, and highly experienced engineering and installation teams, we successfully completed all of the audio visual and UC systems for MPK20 under an extremely tight timeline. We commissioned over 300 rooms in just four weeks. The project was completed in May 2015.



*\*Pictures copyright of ELB Inc. and Forbes, Wired and Popular Science magazines*



## NSW DEPARTMENT OF EDUCATION – PREFERRED SUPPLIER

As a global company, we have a number of international reference sites that demonstrate our capacity for large scale rollouts of education technology. Our most successful implementation and biggest global customer is the New South Wales (NSW) Department of Education. We have been supporting NSW DET for over 20 years with the evaluation, procurement, implementation and ongoing maintenance of classroom audio visual technologies across hundreds of urban, rural and distance education schools. Other highlights of the scope of our services and support include:



- **NSW DET Connected Classrooms Program** – 2,250 schools supplied with interactive whiteboards as well as monitors for video conferencing
- **BER (Building the Education Revolution) Program** – 3,800 interactive whiteboards delivered and installed in a 6 month time frame
- **NSW Department of Education and Training (DET) supply contract** – ELB has been contracted to provide professional development and training programs and services since 2004 with millions of dollars in spend each year



- **Discretionary Purchasing** – averaging around 220 interactive whiteboard bundles per month, plus thousands of other audio visual products including projectors, document cameras, 3-D printers, classroom audio systems, student response systems, Chromebooks, Apple Ipods, mobile charging carts, video conferencing equipment, and much more.



The path to this successful partnership has included many avenues but was consistently focused on the support and professional development we provided along with way. A dedicated Education Consultant (EC) was assigned to each of the 10 regions. While the main goal of the EC was to build technical expertise among teachers within the school, it was also important that it start with the Principal. We shared our expertise with regards to technology integration and helped to align that with the strategic goals of the school. We demonstrated our solution to teachers, administration, as well as the Parent Organizations.

Once a purchase was made, the EC worked to develop a training plan with the region. This plan included a combination of online webinars and face-to-face training sessions. From there, Digital User Groups (DUG's) were created, fostering a network of teachers sharing lessons and training each other. Once a year, we would host a large Teachers' Conference within the State to provide access to thought leaders within the education community, product knowledge, and opportunities for training.



## GOOGLE – MASTER SERVICE AGREEMENTS

ELB is one of three preferred audio visual suppliers for Google. As a result, we currently provide AV design and integration services for Google globally, including locations in Asia, Australia, Europe and throughout the United States.



Our ongoing integration work includes a variety of new and existing AV spaces, as well as installing Google Video Conferencing (GVC) and Tech Talk rooms across multiple campuses. To date, we have provided products and services to over 700 rooms across over 30 Google campuses. Many of these projects are part of the company's audio visual Moves, Additions, and Changes (MAC) program.

Our work for Google in Texas has included the full audio visual fit-out for the company's regional campus located in Austin. Our work included the design, procurement, installation, commissioning and training of audio visual systems for over 30 conference, meeting, training, and huddle rooms, as well as unique event spaces.

ELB also currently provides services and support under an Enterprise Maintenance Agreement. As part of this contract, we offer technical support and maintenance services to all the rooms noted above and more.

Furthermore, ELB is also intimately involved in Google's evaluation of collaboration technologies and provides input on integration with existing Google systems and technology. On the design side we also engage with Google on a consulting basis, providing audio visual design services and conference room standards creation.



On the education side, we are excited to be working with Google to help ensure the effective deployment and management of Chromebook devices and licenses across schools, districts and other learning centers. ELB is a Google for Education Partner and as such we are committed to quality, reliable service to our education customers.

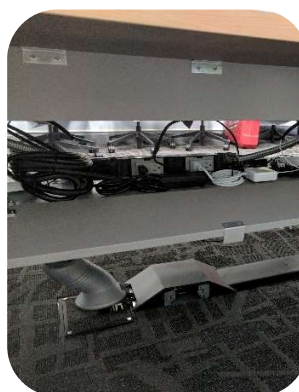
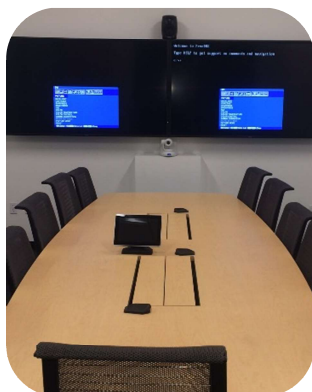
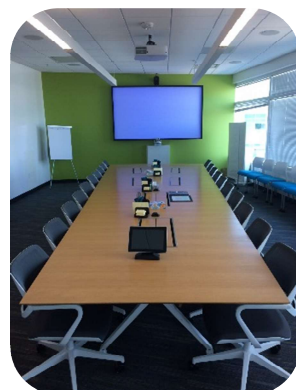
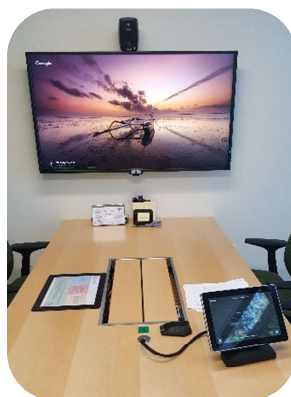
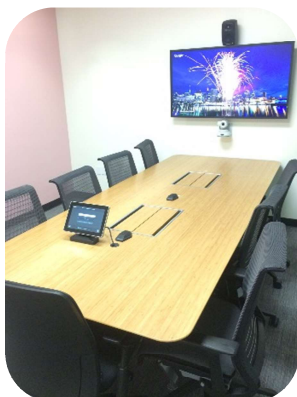

---

## REFERENCES

**Customer: Saugus Union School District (Santa Clarita, CA)**

Contact: Mike Leathers

Telephone: 661-294-5300

Email: [mleathers@saugusd.org](mailto:mleathers@saugusd.org)

Scope: In June of 2016, ELB responded to a bid for over 450 65” and 75” panels on both mobile, mobile tilt, and height adjustable wall mounts. ELB won the bid and installed over 470 panels at 15 different school sites and the district office at a rate of one site per day. At the time, this was the largest one time rollout of interactive flat panels in the country. We continue to provide panels, service and training to the district office each school site.

**Customer: Redlands Unified School District (Redlands, CA)**

Contact: Jennifer Hosch

Telephone: 909-307-2430

Email: [Jennifer\\_hosch@redlands.k12.ca.us](mailto:Jennifer_hosch@redlands.k12.ca.us)

Scope: Beginning in the Fall of 2016, ELB installed a number of Prowise 65” panels on mobile tilt lifts at Judson & Brown Elementary. Later that year and into 2017, 2018 and 2019, ELB has delivered more than 60 Prowise panels and NorvaNivel furniture to various schools throughout the school district. We continue to provide training and professional development to teachers and administrators throughout the district.

**Customer: Aspire Titan Academy (Huntington Park, CA)**

Contact: Jhonn Hernandez

Telephone: 323-583-5421

Email: [jhonn.hernandez@aspirepublicschools.org](mailto:jhonn.hernandez@aspirepublicschools.org)

Scope: In June of 2016, ELB installed 12 65” Prowise panels on tilt lifts were installed at their Huntington Park, CA location. Training and professional development was also provided to all teachers on two different occasions. In June of 2018, four more 65” Prowise bundles were implemented at the same campus.

Terms & Conditions  
Inclusions & Exclusions  
Payment Terms

---



**ELB**

CREATE.  
COMMUNICATE  
COLLABORATE.

---

## TERMS AND CONDITIONS

- 1. Application of Terms and Conditions:** The terms and conditions of this quote shall apply to the sale and purchase of the listed Products in this quote, except where either (1) modified herein by ELB; or (2) where ELB and the Customer are parties to a current written agreement which governs the sale and purchase, the provisions of the said Agreement shall prevail.
- 2. Quote:** This quote shall not be binding on ELB until accepted in writing by the Customer and returned to ELB. This quote is firm for 30 days unless modified in writing by ELB. Maintenance prices are subject to a separate maintenance agreement available on request. The Customer acknowledges that where any of the Products listed in this quote are unavailable 30 days from the date of acceptance of the quote by the Customer, and the price of any Product quoted changes in that period, ELB reserves the right to issue a fresh quote to the Customer for those Products listing the new prices.
- 3. Exchange Rate:** In the event that the prevailing exchange rate between the currency of the country of origin and the currency quoted has fluctuated from the time the quote is rendered to the time of payment is received from the Customer, ELB reserves the right in its sole discretion to adjust any prices quoted herein and the Customer agrees to meet the revised price. For the purpose of this quote as an agreement, the prevailing exchange rate at the time of the quote shall be the rate specified, (at the time payment is received) to be that issued by the Commonwealth Bank of Australia for a spot transaction on that day.
- 4. Payment:** All Products shall be paid for by the Customer (including all government duties and taxes applicable) prior to delivery. Alternatively if ELB and the Customer have prior to delivery of the Products agreed on and maintain a credit arrangement, payment will be in accordance with the terms and conditions of the credit arrangement.
- 5. Ownership of Products:** The ownership of all Products shall remain with ELB and shall only pass to the Customer upon the payment by the Customer of the invoiced price in full. Prior to payment of the invoiced price in full, the Customer shall hold the Products as Bailee for ELB. In the event of the Products whether in the same or a modified form being disposed of prior to the payment of the invoiced price in full, any amount received by the Customer shall be held in trust by the Customer for ELB. All prices quoted are in US dollars, unless otherwise specified.
- 6. Delivery of Products:** Delivery of Products shall take place at the time of the physical taking of the Products by the Customer or by the carrier whether engaged by ELB or the customer or 10 days after ELB notifies the Customer that the Products are ready for delivery, whichever first occurs. Where the Customer arranges its own carrier, it shall be responsible for all freight, insurance and other costs associated with the carriage. Where ELB arrange carriage, all freight and insurance and other costs shall be to the account of the Customer.
- 7. Cancellation and Rescheduling of Orders:** (1) Cancellation: Where any order is cancelled by the Customer on or less than seven (7) days prior to the scheduled shipment date, the Customer will still be charged the entire invoice cost of the quote as a cancellation fee. (2) Rescheduling: Orders may only be re-scheduled up to thirty (30) days from the scheduled shipment date. Any rescheduling occurring in less than thirty days prior to the scheduled shipment date will be subject to a rescheduling charge equal to 40% of the gross order value.

- 
8. Authorized Returns: Customer shall not return any ELB Product for credit, exchange or otherwise without the prior written consent of ELB evidenced by ELB authorizing and issuing to the Customer an ELB Return Authorization.
  9. Restocking Fee and Return of Products: Where a Customer returns a Product (not due to a defect) to ELB under the ELB Return Authorization then a restocking fee will be charged. The restocking fee is based on the value of the Product returned. Where the Product returned was charged to the Customer (1) for less than \$1,000 (excluding Tax) the fee is \$80.00 plus Tax plus the cost of any freight charges incurred by ELB; or (2) for more than \$1,000 (excluding Tax) the fee will be 15% of the value charged plus Tax plus the cost of any freight charges incurred by ELB. Any Products returned to ELB will only be accepted if the Product is in its original condition as originally shipped and returned as packed in its original packaging, including all accessories, cables and manuals. Where ELB determines, acting reasonably, that any Product returned requires rectification or repair or is not as originally shipped or as originally packaged, ELB is entitled to charge the Customer the cost of and any fee incurred to return that Product to its original condition. ELB also reserves the right at its discretion to charge the Customer for all courier charges or a pick up charge as incurred by ELB to collect the Product from the Customer if the Product is not returned by the Customer by freight.
  10. No Warranty: ELB does not manufacture any Product and accordingly does not warrant that any Product is free of any defect, is fit for the purpose required by the Customer or is of merchantable quality. The Customer must make and rely on their own enquiries and rely at their own expense on the warranty and warranty periods as may be provided by the manufacturer of any particular Product in this quote.
  11. Services: Where this quote includes details of time charges, services required to be undertaken and/or installation of Products required at the Customer site, to be undertaken by ELB in addition to the Products to be purchased (Services) the following conditions apply: (1) Acceptance by the Customer of this quote which includes the Services means acceptance by the Customer of the following conditions in sub-paragraphs (2) to (6) namely; (2) An ELB Scope of Works (SOW) agreed and signed by the Customer prior to the commencement of the Services; (3) Acceptance of this quote by the Customer does not affect or amend the terms and conditions of the SOW; (4) All work required to be undertaken under the Services, including the payment terms, will be governed by the terms and conditions of the SOW; (5) Any variation of the SOW does not affect the terms and conditions of this quote; and (6) Where any variation to the Services is required by the Customer a separate quote and an amendment of the SOW will be provided by ELB for that variation.
  12. Limitation of Liability: In no event shall ELB be liable to the Customer for incidental or consequential damages (including loss of profits) of any nature arising out of or related to the supply, design, manufacture, installation or service or the performance or use of any Products or alternatively in the event that ELB are found liable for a breach of warranty or condition implied by law and not capable of exclusion by agreement. Where ELB is found liable that liability shall be limited to the minimum level possible under the law.
  13. Severability: If any of the terms and conditions hereof shall to any extent be invalid or unenforceable, the remainder of these the Terms and conditions, or the application of such the terms and provisions to persons or circumstances other than those as to which it is held unenforceable shall not be affected thereby.
  14. Applicable Law: The validity, interpretation and performance

---

## INCLUSIONS & EXCLUSIONS

### ELB Will Provide/Install

- 65” or 75” Prowise Touchscreen on either a tilt lift, mobile lift or height adjustable wall mount
- Professional Installation of equipment listed above
- Professional management/coordination of project
- All necessary training

### Magnolia Public Schools Will Provide/Install

- Wall backing to support height adjustable wall mount
- Electrical outlets for equipment listed above
- Any/All paint or patchwork after installation

---

## PAYMENT TERMS

ELB acknowledges and accepts payment terms as no later than 60 days after invoice date. The payment will not be issued until after both the Vendor and MPS agree that the project is complete and meets all requirements. This will be accomplished via a Handover Certificate from ELB to MPS upon completion of said project.



# Technical Support, Warranty and Repair

---



**ELB**

CREATE.  
COMMUNICATE.  
COLLABORATE.

---

## TECHNICAL SUPPORT AND REPAIR

With our experience in the audio visual integration business we find that each customer is different and has their own unique set of requirements. ELB would like to work with MPS in determining these requirements for terms and conditions surrounding warranty and legacy equipment. At that stage we can create a personalized agreement that is mutually agreed upon and provides MPS the comfort that a strategy is in place for both existing and future technologies.

ELB is dedicated to providing all our customers with quality technology solutions, as well as great customer service. But our service doesn't end when the purchase and training is complete. We are committed to providing the support needed should any technical issues or challenges arise. With state of the art repair facilities, in-house technical support staff, and a strong commitment to quality, we can provide comprehensive and prompt technical support services for valuable technology assets.

### Authorized Repair Center

ELB is authorized to perform technical repairs on a variety of manufacturer products. We are also a Prowise Certified Repair Partner, which ensures we perform repairs within the highest standards at all time. The Prowise Certified partner is required to annually attend training course to ensure these standards are met.



---

### TOLL-FREE HELPDESK

To ensure critical service and support is available to all our customers, ELB maintains a national toll-free Helpdesk staffed by qualified technicians and trained engineers who can provide technical trouble-shooting advice over the phone to anyone in North America. Our Service Helpdesk receives, responds to and coordinates all technical support, warranty and repair services across North America.

Using a variety of voice, video, and data solutions, our service technicians can often fix many common faults without requiring a site visit. These remote tools improve our response time and reduce unnecessary costs of supporting the technology. Our qualified and experienced service technicians have gone through extensive training to fully diagnose and support all of the products we sell.

All incoming fault calls are logged into ELB's custom built management database. Information can be accessed by engineers throughout the company, allowing our central helpdesk team to monitor and access accurate real-time information on any support or maintenance requirement.



The ELB Helpdesk is operational Monday to Friday from 8:00am to 7:00pm (PST)

Phone: 1-800-806-5581

Email: [Service@elbglobal.com](mailto:Service@elbglobal.com)

A marketing brochure which highlights more of our warranty and technical support services and capabilities is shown on the next page.

---

## TECHNOLOGY REPAIR PROCESS

Should a customer experience an error or technical difficulty with their technology device, either legacy or new, the following escalation process should be used:

1. Technical difficulty with the device is detected or noted by customer
2. Customer to contact the **ELB Technical Support Helpdesk** through one of the following ways:
  - a. **Online** – Fill out and submit the customer inquiry form on the Contact Us page on [www.elbglobal.com](http://www.elbglobal.com)
  - b. **Phone** – Our Customer Support Center is available from 8:00 am to 6:00 pm PST (Monday to Friday) and can be reached through a toll-free number at 1.888.506.7275
  - c. **By Email** – Send a technical support question or request to [serviceus@elbglobal.com](mailto:serviceus@elbglobal.com)
  - d. **By Fax** – Send a technical support question or request to us by facsimile to 925.475.5096
3. ELB Technical Support Specialist receives customer request or inquiry and logs in Service Database
4. ELB Technical Support Specialist contacts customer within 4 hours for urgent matters, and 1 business day for non-urgent matters. The following sequence of activities will take place:
  - I. **Troubleshooting** – All attempts will first be made to troubleshoot the product issue with the customer. Various communication methods can be used for better accuracy and results.
  - II. **Onsite Repair** – When troubleshooting is unsuccessful, ELB Product and Technical Support Specialists will determine whether an onsite service visit would prove helpful. If yes, a service ticket will be sent to the regional technical service representative for follow-up. An appointment with the customer will be set up within 48 hours, with the onsite repair to take place within 5 business days.
  - III. **Product Return/RMA** – In the event the product is deemed faulty and an onsite service visit will/did not resolve the issue, the ELB National Technical Service Manager will activate the RMA process. The customer will be provided with step-by-step instructions on how to return the product to the ELB Service and Repair Center. They will also be provided with regular formal communication on the status and outcome of the repair process. The Manufacturers Product Warranty Agreement outlines the product repair or replacement requirements. More details about this process is outlined on the previous page.
5. Once the issue has been resolved, the ELB Technical Support Specialist will close the service ticket and issue a Customer Satisfaction Survey – Service/Repair to the customer.
6. Customer is encouraged to complete the questionnaire and return it to ELB as soon as they are able.

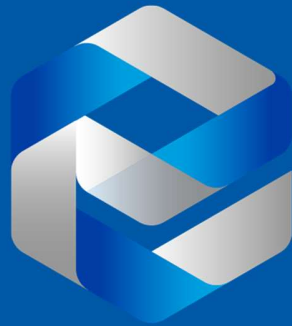

**ELB** | CREATE. COMMUNICATE. COLLABORATE.

**Sales** 1.888.506.7275

**Service and Support** 1.800.806.5581



### The choice for the future

With the Prowise Touchscreen you can carelessly enjoy the world's highest visual and audio quality.

The equipment used is of the highest level and combined with the hardware and software developed by Prowise provide unique education and presentation possibilities. The low energy consumption, the revolutionary price and the standard 5-year warranty offer an unprecedented total cost of ownership.

The modern specifications, including four processors, result in a super fast and reliable touchscreen.

55": [PW.1.15055.0001](#) | 65": [PW.1.15065.0001](#) | 75": [PW.1.15075.0001](#) | 86": [PW.1.15086.0001](#)

Screen	55"	65"	75"	86"
Bezel color	Brushed aluminium (grey)	Brushed aluminium (grey)	Brushed aluminium (grey)	Brushed aluminium (grey)
Diagonal	55 inch	65 inch	75 inch	86 inch
Panel type	Ultra HD LED - IPS	Ultra HD LED - IPS	Ultra HD LED - IPS	Ultra HD LED - IPS
Resolution	3840 x 2160 @ 60Hz	3840 x 2160 @ 60Hz	3840 x 2160 @ 60Hz	3840 x 2160 @ 60Hz
Glass plate	Anti-Glare Pro	Anti-Glare Pro	Anti-Glare Pro	Anti-Glare Pro
Glass thickness	4 mm / 0.16 inches	4 mm / 0.16 inches	4 mm / 0.16 inches	4 mm / 0.16 inches
Glass hardness	Mhos 7	Mhos 7	Mhos 7	Mhos 7
Aspect ratio	16:9	16:9	16:9	16:9
Contrast ratio	1200:1	1200:1	1200:1	1200:1
Brightness	350 cd/m2	350 cd/m2	350 cd/m2	350 cd/m2
Number of colors	10 Bit (1.07B)	10 Bit (1.07B)	10 Bit (1.07B)	10 Bit (1.07B)
Viewing angle	178°	178°	178°	178°
Panel refresh rate	60Hz	60Hz	60Hz	60Hz
<b>Modules</b>	55"	65"	75"	86"
PC module slot	Yes, OPS slot	Yes, OPS slot	Yes, OPS slot	Yes, OPS slot

<b>Touch type</b>	55"	65"	75"	86"
Type	HAPro 3	HAPro 3	HAPro 2	HAPro 2
Multi-touch	Yes (32 points)	Yes (32 points)	Yes (20 points)	Yes (20 points)
Multi-writing	Yes (16 points)	Yes (16 points)	Yes (10 points)	Yes (10 points)
Auto-calibration	Yes	Yes	Yes	Yes
Resistant to sunlight	Yes	Yes	Yes	Yes
Supported OS	Windows 7, 8.1 & 10/Mac OS/Linux/Android and Chrome OS	Windows 7, 8.1 & 10/Mac OS/Linux/Android and Chrome OS	Windows 7, 8.1 & 10/Mac OS/Linux/Android and Chrome OS	Windows 7, 8.1 & 10/Mac OS/Linux/Android and Chrome OS
<b>Audio</b>	55"	65"	75"	86"
Speakers	2.1 sound (3 speakers)	2.1 sound (3 speakers)	2.1 sound (3 speakers)	2.1 sound (3 speakers)
Front speaker power	2 x 18W (8Ω)	2 x 18W (8Ω)	2 x 16W (8Ω)	2 x 16W (8Ω)
Sub woofer power	1 x 15W (8Ω)	1 x 15W (8Ω)	1 x 15W (8Ω)	1 x 15W (8Ω)
Dolby Audio	Yes	Yes	Yes	Yes
<b>Microphone</b>	55"	65"	75"	86"
Type	Microphone Array	Microphone Array	Microphone Array	Microphone Array
Number of Microphones	4	4	4	4
Auto Switch (Windows/Central)	Yes	Yes	Yes	Yes
<b>ProWrite</b>	55"	65"	75"	86"
Number of Pens	2	2	2	2
Multi-color Writing	Yes	Yes	Yes	Yes
Multi-size writing	Yes	Yes	Yes	Yes
<b>Special features</b>	55"	65"	75"	86"
Prowise Central	Yes	Yes	Yes	Yes
Over the Air Updates (OTA)	Yes	Yes	Yes	Yes







## Dimensions Prowise Touchscreen 55"

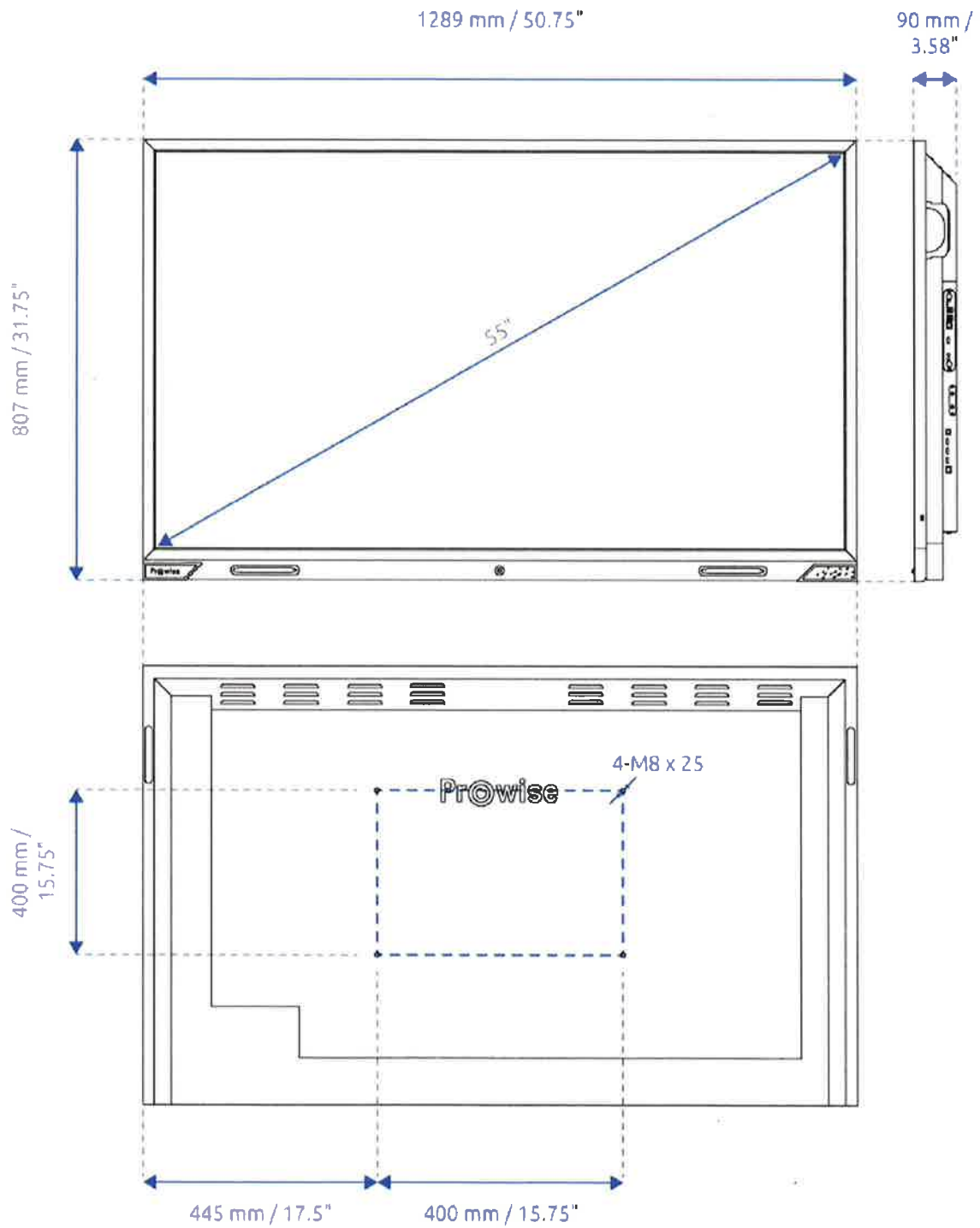

# Dimensions Prowise Touchscreen 65"

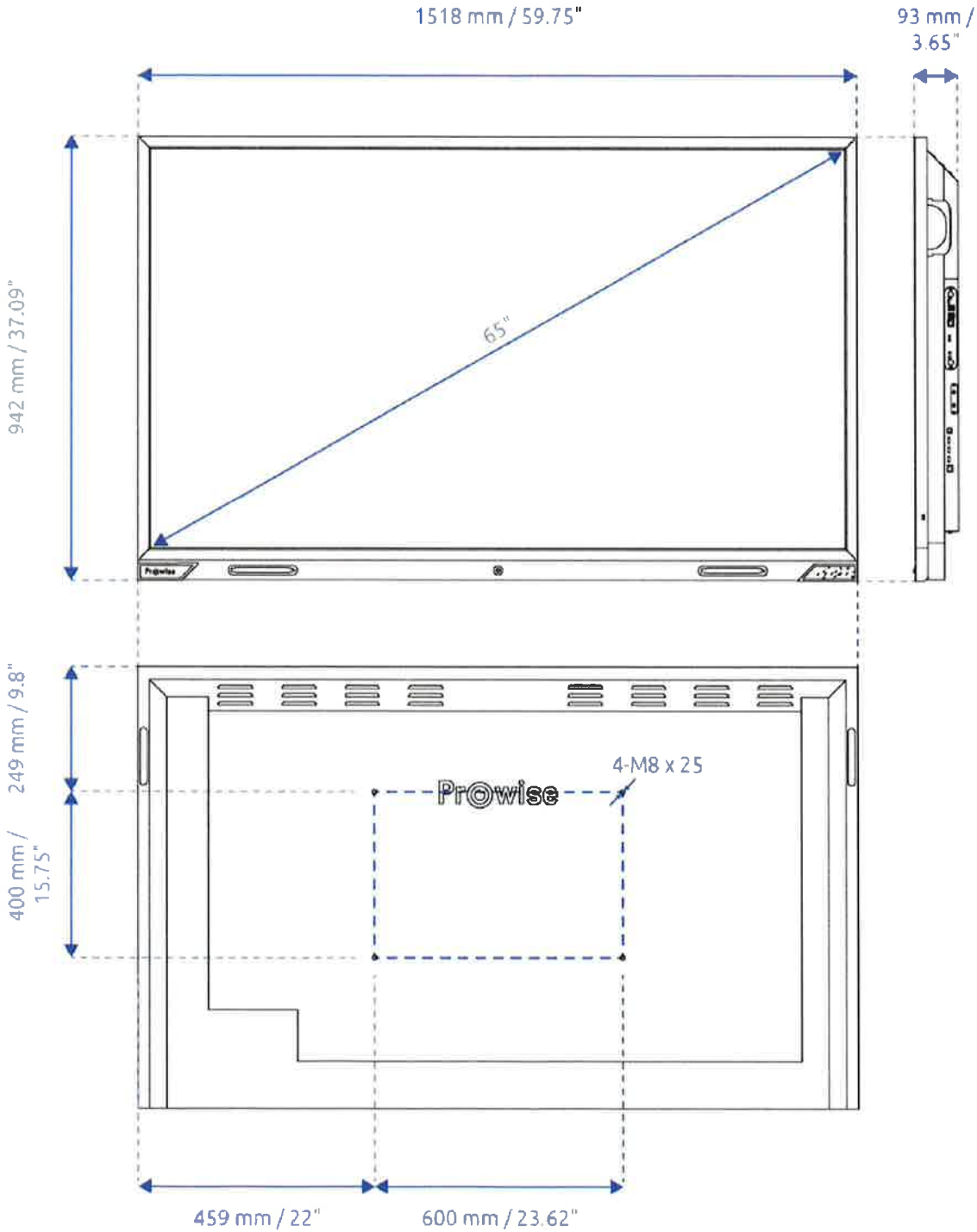

## Dimensions Prowise Touchscreen 75"

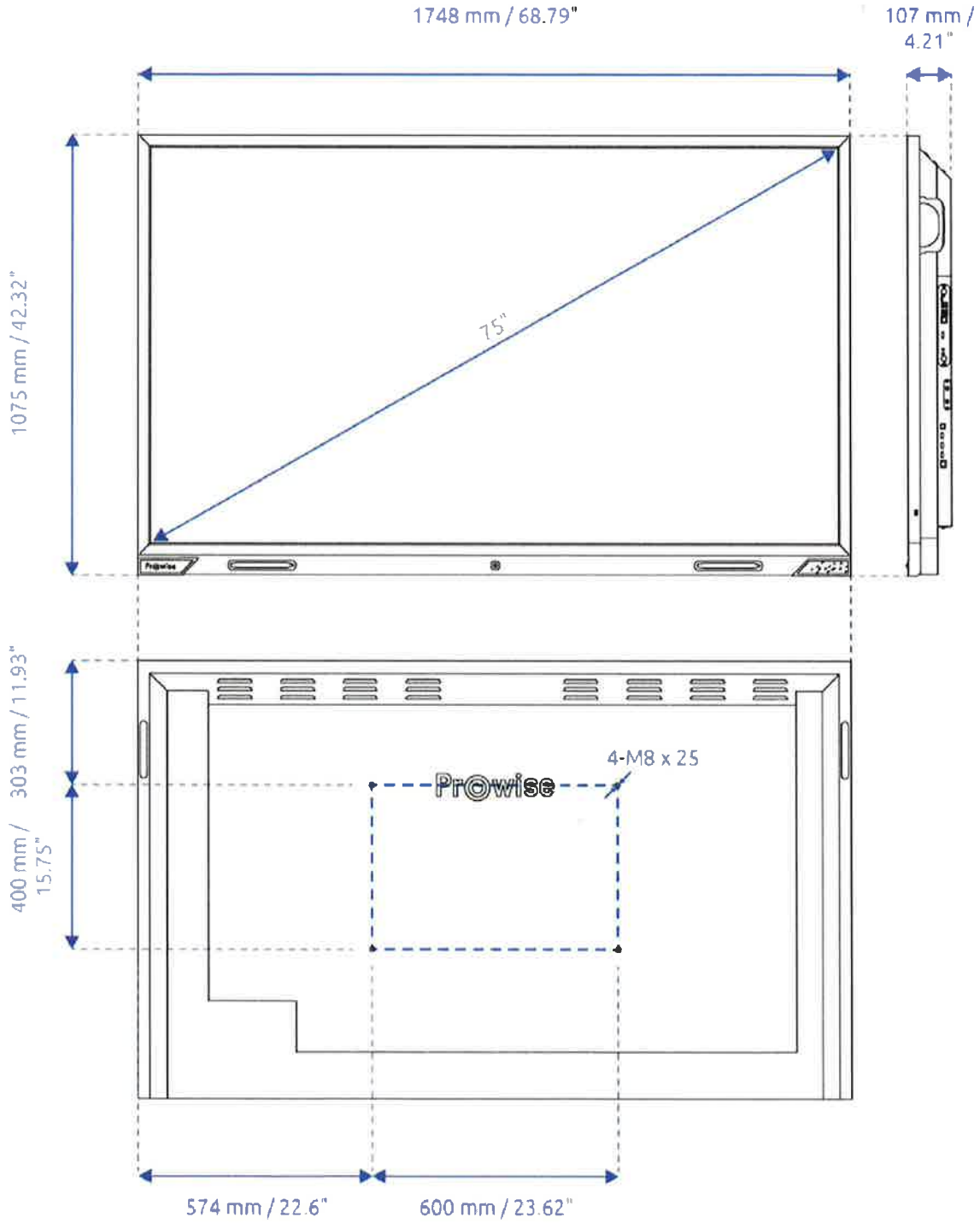

## Dimensions Prowise Touchscreen 86"

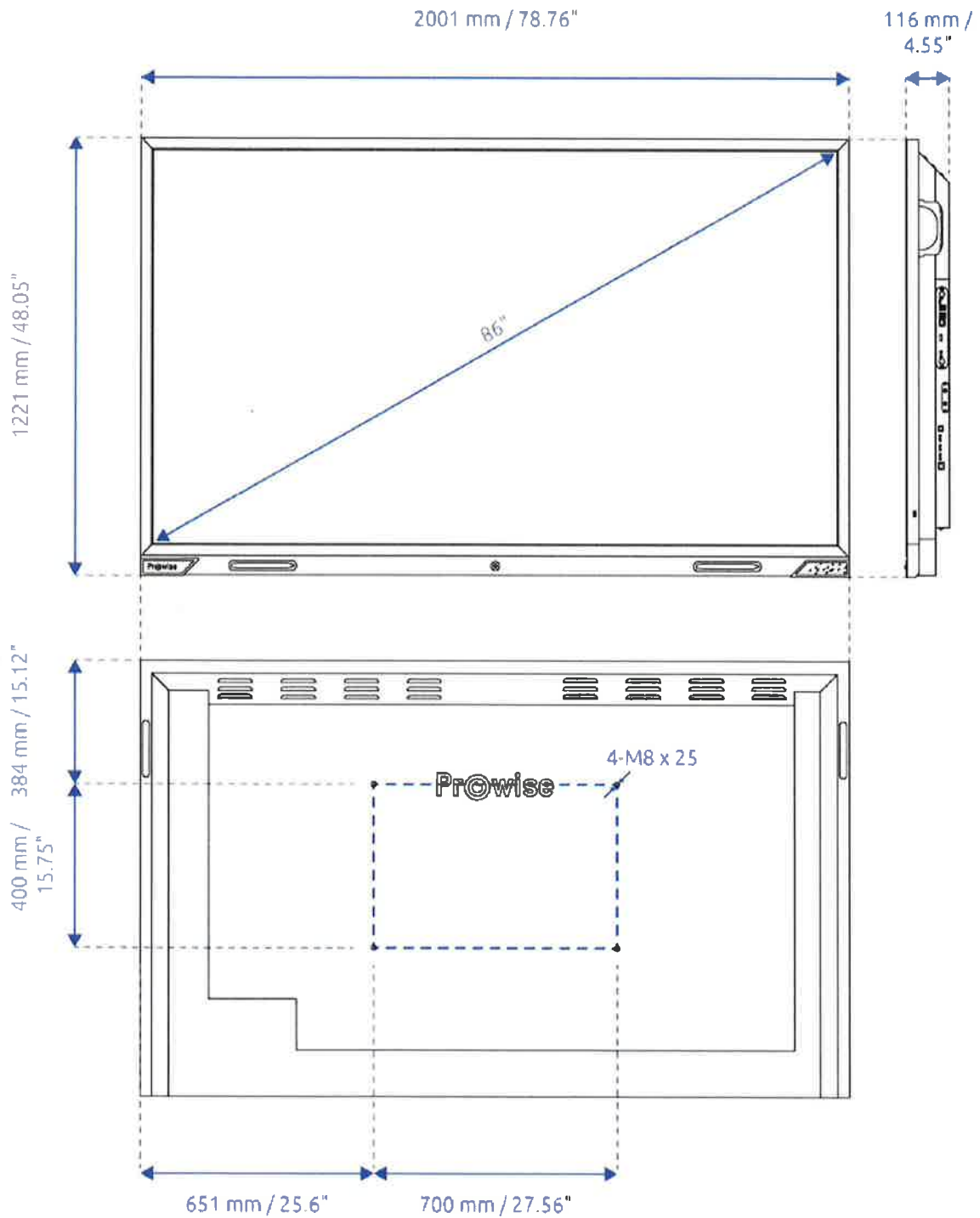

## Prowise iPro Wall Lift

Ensure your touchscreen is always positioned at the right height with a lift system attached to the wall.



PW.1.21002.0002

Suitable for	All Prowise touchscreens, maximum dimensions VESA mount 800 x 600 mm
Dimensions ground surface (WxDxH)	785 mm x 222 mm x 71 mm
Maximum load	110 kg
Speed of the lift	38 mm /s
Power	100-240V AC 50-60Hz (universal)
Stand-by power consumption	0,1 Watt
Duty cycle columns	5%
Soft-start and soft-stop	Yes
Noise level	Low, standard < 55 dB (A)
Protection against overload (EOP)	Yes
Columns with integrated anti-collision sensors	Yes, PIEZO™ sensors
Material	Steel/ABS
Colour	Steel = RAL 9005 / ABS = RAL anthracite/black
Keyboard storage (option)	Yes, with the Prowise iPro Keyboard Tray for storing your keyboard, mouse and other accessories.
Option to place the lift at a greater distance from the wall	Yes, with the iPro Wall lift extension kit
Touchscreen control via Prowise Central	Yes, USB connection
Foot controller	Yes

Certifications	CE
Warranty	5 year
Gross weight	41 kg
Net weight	37 kg
Dimensions of the total packaging (WxDxH)	887 mm x 235 mm x 965 mm

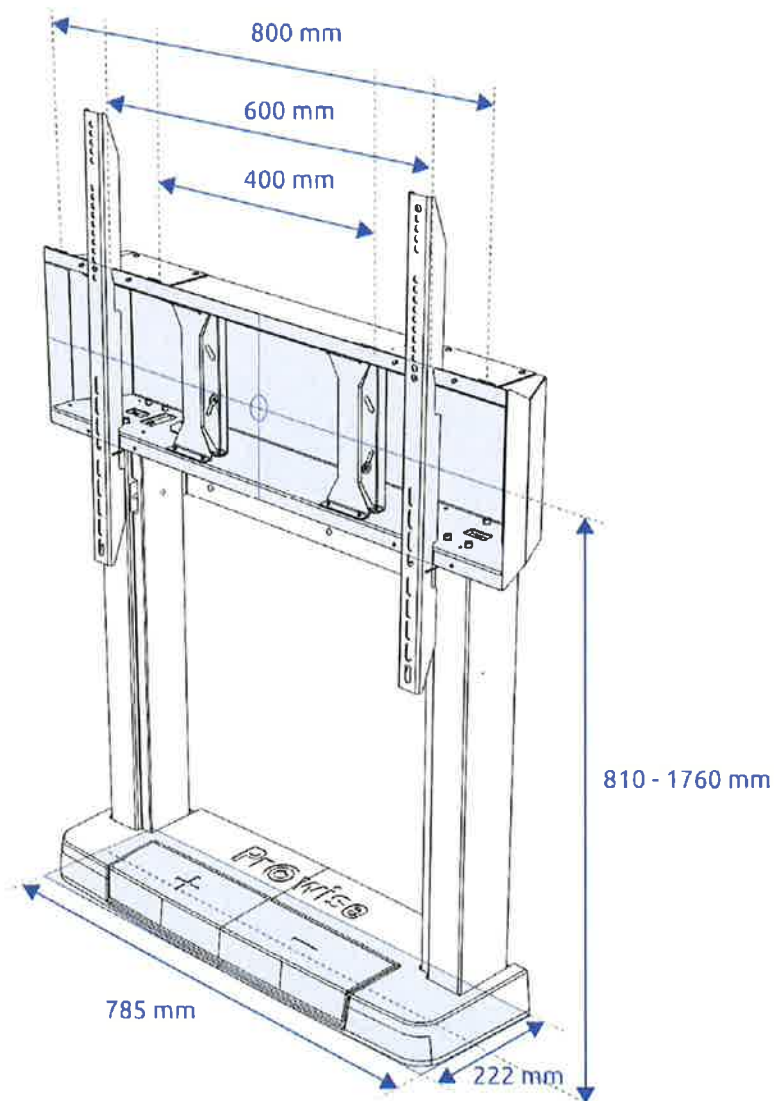

## Prowise iPro Tilt & Toddler Lift

Adjust height and angle of the touchscreen and move it to any location. Due to the tilt option the touchscreen can also be used as a touch table. The Toddler Lift is able to descend such that even the shortest students can participate.



iPro Toddler Lift PW.1.21007.0002

iPro Tilt Lift PW.1.21005.0003

Suitable for	Prowise touchscreens up to 65 inch, Maximum dimension VESA mount 800 x 600 mm
Dimensions ground surface (WxDxH)	690 mm x 690 mm x 160 mm
Maximum load	75 kg
Speed of the lift	38 mm/s
Power	100-240V AC 50-60Hz (universal)
Stand-by power consumption	0,1 Watt
Duty cycle columns	5%
Soft-start and soft-stop	Yes
Noise level	Low, standard < 55 dB (A)
Protection against overload (EOP)	Yes
Columns with integrated anti-collision sensors	Yes, PIEZO™ sensors
Material	Steel/ABS
Colour	Steel = RAL 9005 / ABS = anthracite/black
Touchscreen control via Prowise Central	Yes, USB connection
Foot controller	Yes
Remote control	Yes
Wheels	Double safety wheels, ∅100 mm, made of polyamide
Certifications	CE

Warranty

5 year

Gross weight

64 kg (iPro Toddler Lift)  
70 kg (iPro Tilt Lift)

Net weight

55 kg (iPro Toddler Lift)  
61 kg (iPro Tilt Lift)

Dimensions of the total packaging (WxDxH)

887 mm x 712 mm x 780 mm (iPro Toddler Lift)  
887 mm x 712 mm x 920 mm (iPro Tilt Lift)

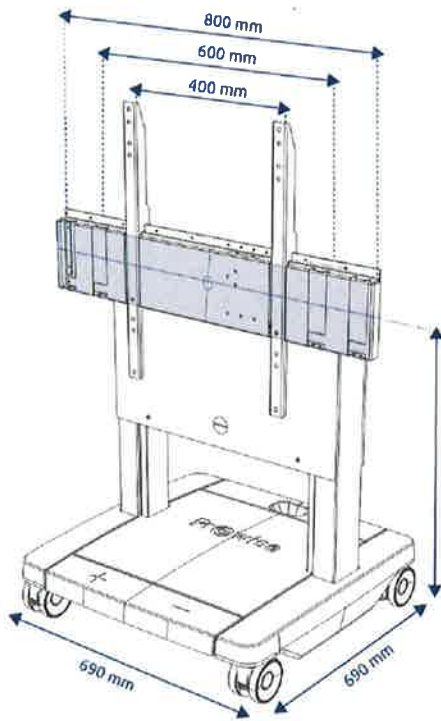

**Toddler Lift**  
653 - 1313 mm  
**Tilt Lift**  
835 - 1635 mm

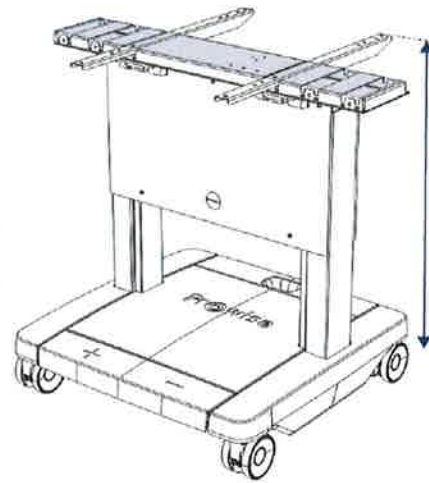

**Toddler Lift**  
630 - 1290 mm  
**Tilt Lift**  
812 - 1612 mm



## Lifts

With the right lift, you'll get the most out of your touchscreen. Want it to stay steady on the wall? Or do you want to tilt and move it around? Whatever you need, we have the right lift for it.



	All-in-One lift (late 2015 model)	Mobile Lift	Wall Lift
Min height vertical position	989 mm / 38.94 inches	1192 mm / 46.93 inches	1283 mm / 50.51 inches
Min height horizontal position	664 mm / 26.14 inches	N/A	N/A
Max. height vertical position	1649 mm / 64.92 inches	1852 mm / 72.91 inches	2138 mm / 84.17 inches
Max. height horizontal position	1324 mm / 52.13 inches	N/A	N/A
Measurements, ground surface	570 x 630 mm / 22.44 x 24.80 inches	570 x 630 mm / 22.44 x 24.80 inches	550 x 125 mm / 21.65 x 4.92 inches
Range	660 mm / 25.98 inches	660 mm / 25.98 Inches	675 mm / 26.57 inches
Tilt	90°	N/A	N/A
Max lift weight	75 kg / 165.35 lbs	110 kg / 242.51 lbs	110 kg / 242.51 lbs
Applies to	Prowise 42", 55" and 65"	All Prowise screens	All Prowise screens
Wheels	Swivel castor with directional lock, housing made from high grade synthetic materials with metal parts made of Stainless Steel, double ball bearing swivel head	Swivel castor with directional lock, housing made from high grade synthetic materials with metal parts made of Stainless Steel, double ball bearing swivel head	N/A
Wheel diameter	125 mm / 4.92 inches	125 mm / 4.92 inches	N/A
Power	~ 100-120 V (50/60Hz) and ~ 220-240 V (50/60Hz)	~ 100-120 V (50/60Hz) and ~ 220-240 V (50/60Hz)	~ 100-120 V (50/60Hz) and ~ 220-240 V (50/60Hz)
Stand-by power consumption	0,1 Watt	0,1 Watt	0,1 Watt
Duty cycle columns	10% ~ 6 min. of 2 minutes continuous use followed by 18 minutes not in use.	10% ~ 6 min. of 2 minutes continuous use followed by 18 minutes not in use.	10% ~ 6 min. of 2 minutes continuous use followed by 18 minutes not in use.
Duty cycle actuator	10% ~ 6 min. of 2 minutes continuous use followed by 18 minutes not in use.	N/A	N/A
Soft Start / Stop function	Yes	Yes	Yes



Noise level	Low	Low	Low
Protection against overload (EOP)	Yes	Yes	Yes
Anti-Collision TM (software)	No	No	Yes
Column with integrated anti-collision sensor	Yes	Yes	No
Materials	Steel	Steel	Steel
Color	RAL 9006 (column) and RAL 9005 (basebox)	RAL 9006 (column) and RAL 9005 (basebox)	RAL 9006
Keyboard storage included	No	Yes	Yes
UTP config-port	Yes	Yes	No
Hand control remote	Yes	No	No
Keypad	No	Yes	Yes
Certifications	GS/CE/ FCC/IC and RCM	GS/CE/ FCC/IC and RCM	GS/CE/ FCC/IC and RCM
Warranty	5 year	5 year	5 year
Gross Weight	59 kg / 130.07 lbs	64 kg / 141.1 lbs	45 kg / 99.21 lbs
Netto Weight	56 kg / 123.46 lbs	55 kg / 121.25 lbs	41 kg / 90.39 lbs
Dimensions of the total packing (W x H x D)	660 x 322 x 573 mm / 25.98 x 12.68 x 22.56 inches	972 x 574 x 715 mm / 38.27 x 22.6 x 28.15 inches	1255 x 590 x 220 mm / 49.41 x 23.23 x 8.66 inches



# Bringing the Future of Education Technology to Students Today

Prepared for:  
Magnolia Public Schools



**Interactive Displays**

**Proposal & Statement Of Work**

Feb 2019



## COMPANY OVERVIEW

STS Education is a technology solutions company located in Southern California with distribution facilities throughout the US. For more than 15 years STS has been providing the right technology for less money to K-12 schools and has been recognized by Inc. Magazine as one of the fastest growing privately-held companies since 2012. From Second-Life Hardware™ with a lifetime parts warranty to complete IT and Network Management solutions, STS is an upcoming industry leader with a foundation built on legendary customer service.

The roots of STS started in 2001 when then EduTech began providing schools with reconditioned computers in response to a California state initiative that granted technology funding to high schools. In 2010 EduTech merged with Pacific OneSource, under a unified goal to provide cost-effective technology solutions to classrooms nationwide. Today, STS Education is an Ed-tech company that has a curated set of purpose-built for education products, services and solutions that revolve around four areas, Operational Sustainability, Collaboration and Engagement, STEAM and Software.



# Hardware

## PROMETHEAN iSeries Panel – 65" HD & 75" 4K

---

**Full HD to 4K Ultra HD Displays**  
Features crisp details and bright colors

**Infrared Technology**  
Features up to 10 simultaneous touch points

**Built-In Sound**  
Powerful, dual 15 W front-facing stereo speakers

**OPS Slot**  
Select from the Android™ or Windows® Modules to add-on display computing

**Easy Device Connectivity**  
Accessible ports for HDMI® and USB connectivity



The ActivPanel i-Series is the essential interactive panel for customers looking to replace their projector-based systems with a long-term, reliable solution from the world's leading education company. Select from optional display computing, premium sound, and versatile mounting configurations as classroom needs change over time, select from optional display computing, premium sound, and versatile mounting configurations.

# Computing

## ACTIVCONNECT ANDROID OPS

---



### Apps For Instruction

Launch any Android App Store to browse and download apps, games and other content to use on the ActivPanel.



### Mirroring Made Simple

Promethean's ActivCast™ App ensures you can connect Windows®, Mac OS®, iOS®, Chrome OS™ and Android™ to start mirroring.



### Share & Interact With Multimedia Content

Use a connected mobile device to receive, send, draw, or interact with digital lesson content.



### Wireless Presenting

Observe and intervene with individual work teams while mirroring lesson content from anywhere in the classroom using a mobile device.

# Accessories

## **FIXED MOBILE STAND**

---



## **HEIGHT ADJUSTABLE WALL MOUNT**

---



# Software

## ACTIVINSPIRE

---

**Empower teachers to bring lessons to life by enabling student interaction and collaboration on interactive whiteboards and interactive panels.**



### Dual Interface

Easily switch between “Primary” for young learners and “Studio” for older students.



### Support for Mathematical Equations

Use the Equation Editor to add mathematical equations into a flipchart or into questions or response options for learner response devices.



### Integrated Tools

Deliver engaging lessons on your front of the classroom display surface with Revealer, Spotlight Focus Tools, Magic Ink, Clock and Math tools



### Increased Collaboration

Dual-user input and pen and multi-touch functionality (dependent on your display surface) encourage students to engage, interact and work together

## CLASSFLOW

---

**Improve student engagement by facilitating the interactive and collaborative use of classroom devices, digital curriculum & assessments for learning.**



### Deliver Interactive Lessons

Engage every student by presenting and sharing interactive lesson materials such as videos, images and other digital content.



### Differentiate Instruction

Customize lesson content and delivery for individual students or different groups.



### Measure Student Learning

Assess student comprehension in the moment of learning through formative assessment and instant polling.



### Extend Learning Beyond the Classroom

Instill in students independent problem-solving skills by implementing student-centered learning models



## Professional Development

The Promethean Professional Services team has the ability and experience to develop a customized solution for implementation, consultation and professional development. All training sessions are designed to engage educators in professional learning that is guided by their needs and requirements to help them seamlessly integrate technology into curriculum and instruction. Promethean Professional Services provides a suite of offerings that will guide you through effective instruction with your Promethean solution. Each implementation begins with a pre-consultation to ensure your educators are receiving courses that will impact their everyday teaching.

- Standards Driven – Aligned to National and Regional Standards.
- Maximize Return on Investment – Informed and inspired teachers utilizing technology to the fullest capacity add to the value of that technology, leading to greater student engagement and greater student achievement.
- Applicable – Consultants provide customized professional services that enable national, regional and local educational institutions reach their goals and initiatives.

Education Consultants will align all training to the district goals, provide quarterly updates on training progress, provide metrics on training outcomes and stay in constant contact with the district on a day-to-day basis making sure both parties are aligned and expectations are being met.

## Maintenance & Technical Support

Phone and online technical support available at no charge and with no time limits directly through Promethean.

The Promethean products should not require any annual maintenance. Any product issues are covered under the Manufacturers Warranty. Detailed Warranty Information can be Found Here: <https://www.prometheanworld.com/products/warranty-activcare>



# Estimated Timeline for Delivery and Install

---

ActivPanels and Wall Mounts/Mobile Stands can be delivered 2 weeks after order is processed with STS Education depending on the availability and need of Magnolia Public Schools. STS Education will be available for Installation between the dates of March 15<sup>th</sup>, 2019 - March 30<sup>th</sup>, 2019 as specified by Magnolia Public Schools.

## **Example Timeline**

- **03/22/19**- Order received by STS Education
- **04/05/19**- ActivPanels, Wall Mounts, and Mobile Stands delivered to Magnolia Public Schools.
- **04/08/19-04/22/2019**- Deployment and Installation of ActivPanels



# iSeries Pricing – 75" with Adj Wall Mount

<b>Magnolia Science Academy 1</b>	<b>Price/Unit</b>	<b>Total</b>
Promethean iSeries 75" 4K (20)	\$3,099.00	\$61,980.00
ActivPanel Adjustable Wall Mount (20)	\$599.00	\$11,980.00
Extended 5 Year Onsite Warranty	Included	
ClassFlow Lesson Delivery Software	Included	
ActivInspire Lesson Building Platform	Included	
Professional Development	Unlimited	
Shipping	Included	
Wall Mount Installation (20)	\$425.00	\$8,500.00
CA Environmental Waste Fee (20)	\$7.00	\$140.00
Tax	\$7,026.20	
<b>Total</b>	<b>\$89,626.20</b>	

<b>Magnolia Science Academy 8</b>	<b>Price/Unit</b>	<b>Total</b>
Promethean iSeries 75" 4K (6)	\$3,099.00	\$18,594.00
ActivPanel Adjustable Wall Mount (6)	\$599.00	\$3,594.00
Extended 5 Year Onsite Warranty	Included	
ClassFlow Lesson Delivery Software	Included	
ActivInspire Lesson Building Platform	Included	
Professional Development	Unlimited	
Shipping	Included	
Wall Mount Installation (6)	\$425.00	\$2,550.00
CA Environmental Waste Fee (6)	\$7.00	\$42.00
Tax	\$2,107.86	
<b>Total</b>	<b>\$26,887.86</b>	

# iSeries Pricing – 75" with Fixed Stand

<b>Magnolia Science Academy 1</b>	<b>Price/Unit</b>	<b>Total</b>
Promethean iSeries 75" 4K (20)	\$3,099.00	\$61,980.00
ActivPanel Fixed Mobile Stand (20)	\$429.00	\$8,580.00
Extended 5 Year Onsite Warranty	Included	
ClassFlow Lesson Delivery Software	Included	
ActivInspire Lesson Building Platform	Included	
Professional Development	Unlimited	
Shipping	Included	
Fixed Stand Installation/Deployment (20)	\$225.00	\$4,500.00
CA Environmental Waste Fee (20)	\$7.00	\$140.00
Tax		\$6,703.20
<b>Total</b>		<b>\$81,903.20</b>

<b>Magnolia Science Academy 8</b>	<b>Price/Unit</b>	<b>Total</b>
Promethean iSeries 75" 4K (6)	\$3,099.00	\$18,594.00
ActivPanel Fixed Mobile Stand (6)	\$429.00	\$2,574.00
Extended 5 Year Onsite Warranty	Included	
ClassFlow Lesson Delivery Software	Included	
ActivInspire Lesson Building Platform	Included	
Professional Development	Unlimited	
Shipping	Included	
Fixed Stand Installation/Deployment (6)	\$225.00	\$1,350.00
CA Environmental Waste Fee (6)	\$7.00	\$42.00
Tax		\$2,010.96
<b>Total</b>		<b>\$24,570.96</b>

# iSeries Pricing – 65" with Adj Wall Mount

<b>Magnolia Science Academy 1</b>	<b>Price/Unit</b>	<b>Total</b>
Promethean iSeries 65" HD (20)	\$2,099.00	\$41,980.00
ActivPanel Adjustable Wall Mount (20)	\$599.00	\$11,980.00
Extended 5 Year Onsite Warranty		Included
ClassFlow Lesson Delivery Software		Included
ActivInspire Lesson Building Platform		Included
Professional Development		Unlimited
Shipping		Included
Wall Mount Installation (20)	\$425.00	\$8,500.00
CA Environmental Waste Fee (20)	\$7.00	\$140.00
Tax		\$5,126.20
<b>Total</b>		<b>\$67,726.20</b>
<b>Magnolia Science Academy 8</b>	<b>Price/Unit</b>	<b>Total</b>
Promethean iSeries 65" HD (6)	\$2,099.00	\$12,594.00
ActivPanel Adjustable Wall Mount (6)	\$599.00	\$3,594.00
Extended 5 Year Onsite Warranty		Included
ClassFlow Lesson Delivery Software		Included
ActivInspire Lesson Building Platform		Included
Professional Development		Unlimited
Shipping		Included
Wall Mount Installation (6)	\$425.00	\$2,550.00
CA Environmental Waste Fee (6)	\$7.00	\$42.00
Tax		\$1,537.86
<b>Total</b>		<b>\$20,317.86</b>

# iSeries Pricing – 65" with Fixed Stand

<b>Magnolia Science Academy 1</b>	<b>Price/Unit</b>	<b>Total</b>
Promethean iSeries 65" HD (20)	\$2,099.00	\$41,980.00
ActivPanel Fixed Mobile Stand (20)	\$429.00	\$8,580.00
Extended 5 Year Onsite Warranty	Included	
ClassFlow Lesson Delivery Software	Included	
ActivInspire Lesson Building Platform	Included	
Professional Development	Unlimited	
Shipping	Included	
Fixed Stand Installation/Deployment (20)	\$225.00	\$4,500.00
CA Environmental Waste Fee (20)	\$7.00	\$140.00
Tax	\$4,803.20	
<b>Total</b>	<b>\$60,003.20</b>	
<b>Magnolia Science Academy 8</b>	<b>Price/Unit</b>	<b>Total</b>
Promethean iSeries 65" HD (6)	\$2,099.00	\$12,594.00
ActivPanel Fixed Mobile Stand (6)	\$429.00	\$2,574.00
Extended 5 Year Onsite Warranty	Included	
ClassFlow Lesson Delivery Software	Included	
ActivInspire Lesson Building Platform	Included	
Professional Development	Unlimited	
Shipping	Included	
Fixed Stand Installation/Deployment (6)	\$225.00	\$1,350.00
CA Environmental Waste Fee (6)	\$7.00	\$42.00
Tax	\$1,440.96	
<b>Total</b>	<b>\$18,000.96</b>	

# Installation Pricing

<b>Magnolia Science Academy 1</b>	<b>Price/Unit</b>
Fixed Stand Installation/Deployment	\$225.00
Wall Mount Installation	\$425.00

<b>Magnolia Science Academy 8</b>	<b>Price/Unit</b>
Fixed Stand Installation/Deployment	\$225.00
Wall Mount Installation	\$425.00



# The Right Technology



**Jeremy Gilbert | K12 Consultant**  
866-499-2580 • [jeremy.gilbert@stseducation-us.com](mailto:jeremy.gilbert@stseducation-us.com)

[www.schooltechsupply.com](http://www.schooltechsupply.com)



March 5, 2019

Magnolia Public Schools  
250 E. 1<sup>st</sup> Street, Suite 1500  
Los Angeles, CA 90012

Re: RFP for Magnolia Science Academy-1 and Magnolia Science Academy-8  
Interactive Displays 2019

To Whom it May Concern:

Pursuant to the above-referenced RFP, this letter is to certify that Pacific OneSource Inc dba STS education ("STS education") is an authorized reseller of Promethean products in the state of California. This authorization is valid through March 5, 2020.

If you have any questions regarding STS education's ability to sell Promethean products, please do not hesitate to contact us.

Sincerely,



Chris Williams  
Head of Channels, Americas Market  
Promethean, Inc.  
[Chris.Williams@prometheanworld.com](mailto:Chris.Williams@prometheanworld.com)

CC: Steve Omlor  
Shawn Runner  
Eric Sweet  
Tanya Hague  
Denise Bashaw  
Kathryn Wolf  
Nicole Blair

# ProColor 652

Touch technology and collaboration are brought to life with the brilliance of our 4K ultra high-definition LCD flat panel Android display.



## Features

- Up to 20 single-point users or 10 dual-touch and gestures users with Touch 360° interactivity, driving collaborative learning to a new level.\*
- Built-in Android OS for touch control plus Whiteboard app.
- 4K video resolution (3,840 x 2,160).
- LED backlighting for energy efficiency.
- Includes MimioStudio™ classroom software with 3-device MimioMobile™ license.

\* Multi-touch available on Windows systems. Mac and Linux are single touch.

## Options

- Internal Windows 10 PC (available with Intel i5 or i7)
- Wall mount
- Wi-Fi module

## Specifications

Dimensions and Weight	
Overall Dimensions (W x H x D)	1,522 mm x 944 mm x 98 mm (61.1 in. x 37.2 in. x 3.9 in.)
Net Weight	46kg (101.4 lb.)
Packaged Dimensions (W x H x D)	1,697 mm x 1,071 mm x 220 mm (66.8 in. x 42.2 in. x 8.7 in.)
Gross Weight	57 kg (126 lb.)
Effective Screen Size (W x H)	1,428 mm x 803 mm (56.24 in. x 31.63 in.)
Active Screen Size (Diagonal)	65 in.
Image	
Display Format Native Resolution	3,840 x 2,160
Aspect Ratio	16:9
Picture Response Time (Gray to Gray)	8 ms
Refresh Frequency	60 Hz
Pixel Pitch	0.496 mm x 0.372 mm
Pixel Density	68.3 DPI (dots per inch)
Panel Resolution	3,840 x 2,160
Display Colors	1.07 B (10-bit)
Brightness (typical)	350 nits
Contrast Ratio	1,200:1

Viewing Angle	Hor. 178°, Ver. 178°
Backlight Life (estimated)	50,000 hours
<b>Touch Tracking</b>	
Tracking Technology	Touch 360° Infrared
Touch Points Operating Systems	20-touch: Windows 7+ Single touch: Mac OS 10.8+, Linux, Chrome
Touch Tool	Stylus, finger (even if gloved), or solid object
Tracking Accuracy	+/-2mm (0 in.)
Tracking Read Speed	>125 frames/s
Tracking Response Time	12 ms
Tracking Points	32,767 x 32,767
<b>Safety</b>	
Anti-Glare Glass	Yes
Protective Glass	4 mm tempered glass Level 7 Mohs
<b>Connections</b>	
Input/Output	<p>Input:</p> <ul style="list-style-type: none"> <li>- VGA x 1</li> <li>- HDMI-4K V1.4 x 2</li> <li>- HDMI-4K V2.0 x 1</li> <li>- PC audio x 1</li> <li>- DisplayPort x 1</li> </ul> <p>Output:</p> <ul style="list-style-type: none"> <li>- HDMI x 1</li> <li>- Earphone out x 1</li> <li>- Digital audio output coax x 1</li> </ul> <p>USB:</p> <ul style="list-style-type: none"> <li>- USB 2.0 x 4 (2 in front, 1 on side, 1 on the bottom)</li> <li>- USB 3.0 x 2 (1 in front, 1 on side)</li> <li>- USB 2.0 Type-B for touch control (on side)</li> <li>- RS-232 x 1</li> <li>- LAN RJ-45 x 1</li> </ul>

Audio	
Output	12 W x 2
Sound System	Stereo
Equalizer	Yes
Sound Status Memory	Yes
Balance	Yes
Environmental	
Storage Temperature	-20° to 60° C (-4° to 140° F)
Storage Humidity	10% to 90%
Operating Temperature	0° to 40° C (32° to 104° F)
Operating Humidity	10% to 90%
Power Requirement	100–240 VAC 60/50 Hz
Power Consumption (Operating)	265 W
Power Consumption (Sleep Mode)	<0.5 W
Mount	
Mounting Screw Size	M8 x 25 mm
VESA Form Factor	600 x 400 mm
Accessories	
HDMI Cable	1 x 3 m
AC Power Cable	1 x 3 m
USB Cable	1 x 5 m

Passive Stylus	3 x magnetic
Remote Control	1 (with batteries)
Wall Mount	Optional
Internal PC Module	Optional
<b>Android</b>	
Version	Android 5.1 "Jelly Bean"
CPU	ARM Cortex A53 Dual Core
GPU	Quad Core
RAM	2 GB
ROM	16 GB

## What's in the box:

### Hardware

- Magnetic stylus x 3
- Remote control with batteries

### Documentation

- MimioStudio license
- Warranty card
- QuickStart Guide

### Cables

- HDMI cable (3 m)
- USB A-to-B for touch (5 m)
- US power cord (3 m)

## Drawings

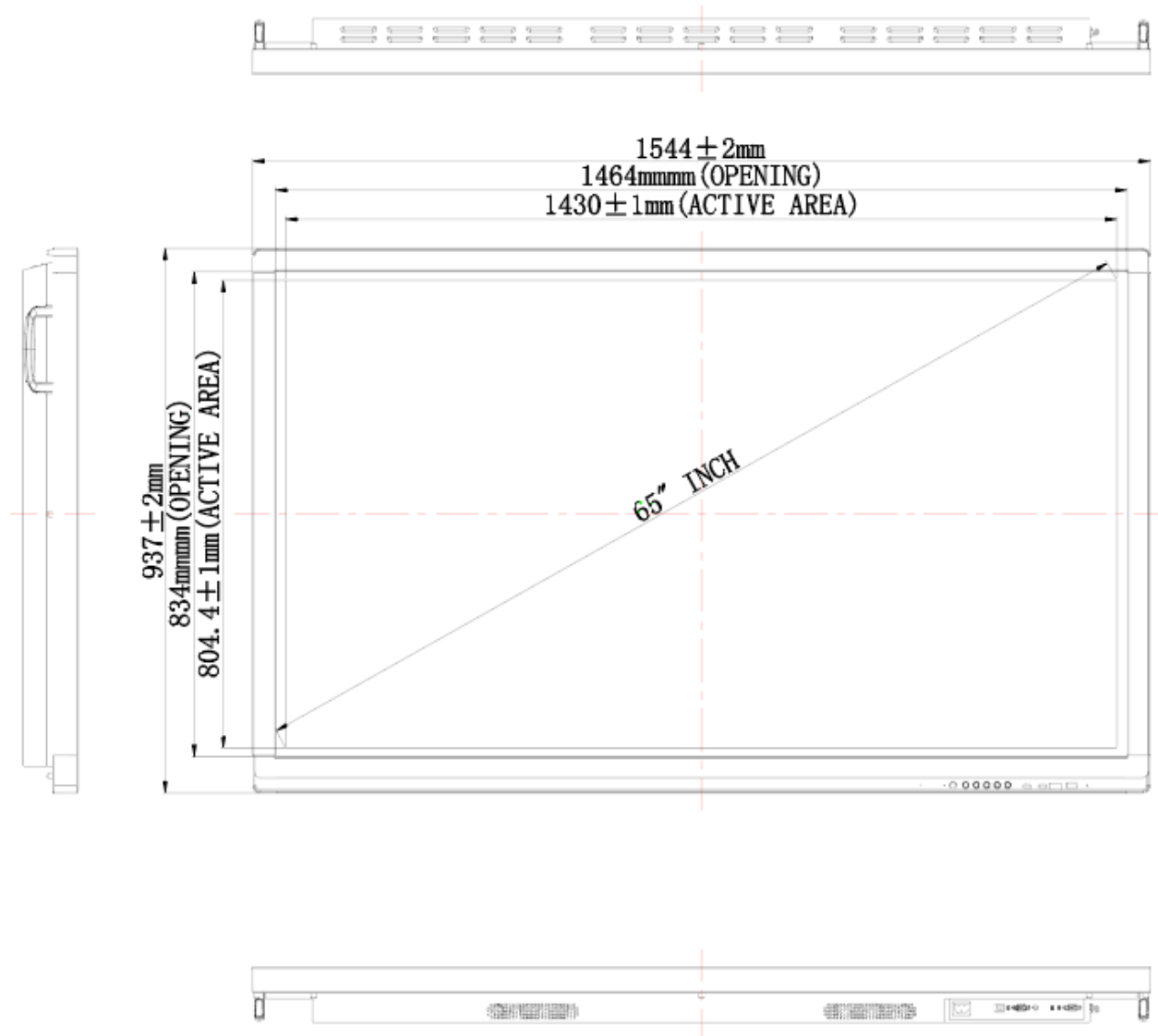

## Connections

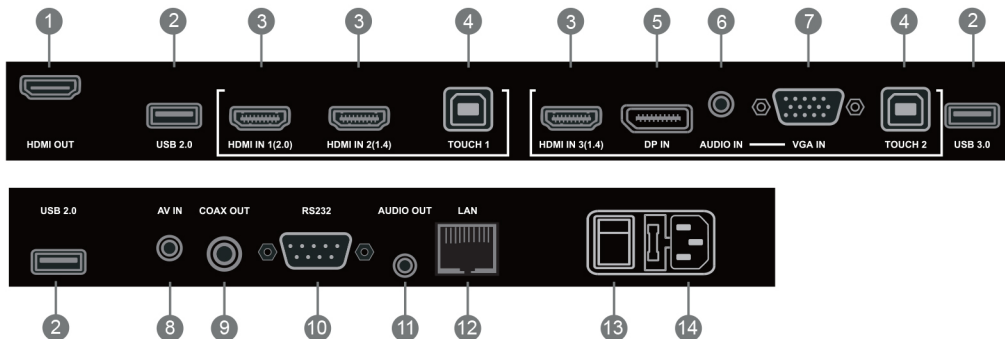

Items	Function description
① HDMI OUT	Displays whatever is on the screen, including Android annotation.
② USB	Connect USB devices such as mobile hard disk, U disk, USB keyboard and mouse, USB drives, etc.
③ HDMI IN	HDMI input
④ TOUCH	Touch signal output for connection to external computer
⑤ DP	DisplayPort input
⑥ AUDIO IN	Line level audio input
⑦ VGA IN	VGA input
⑧ AV IN	Composite video + audio input - 3.5mm 4-conductor
⑨ COAX OUT	Digital audio output - "RCA" connector
⑩ RS-232	Control interface
⑪ AUDIO OUT	Output to an external amplifier and speaker
⑫ LAN	RJ-45 connector
⑬ AC SWITCH	Master power switch
⑭ AC IN	AC power input

HDMI = High-definition multimedia interface

Specifications are subject to change without notice.



# ProColor 752U

Students will see everything with Boxlight's vibrant 75" ProColor interactive LCD flat panel Android display. Touch technology and collaboration are brought to life with the brilliance of 4K ultra high-definition.



## Features

- 75" interactive flat panel display.
- Up to 20 single-point users or 10 dual-touch and gestures users with Touch 360° interactivity, driving collaborative learning to a new level.\*
- Built-in Android OS for touch control plus Whiteboard app.
- 4K video resolution (3,840 x 2,160).
- LED backlighting for energy efficiency.
- Includes MimioStudio™ classroom software with 3-device MimioMobile™ license.

\* Multi-touch available on Windows systems. Mac and Linux are single touch.

## Options

- Internal Windows 10 PC (available with Intel i5 or i7)
- Wall mount
- Android module
- Wi-Fi module

## Specifications

Dimensions and Weight	
Overall Dimensions (W x H x D)	1,764 mm x 1,043 mm x 100 mm (69.5 in. x 41.1 in. x 3.9 in.)
Net Weight	58 kg (127.7 lb.)
Packaged Dimensions (W x H x D)	1,913 mm x 1,225 mm x 280 mm (75.3 in. x 48.2 in. x 11.0 in.)
Gross Weight	82 kg (180.8 lb.)
Effective Screen Size (W x H)	1,650 mm x 928 mm (65.0 in. x 36.5 in.)
Active Screen Size (Diagonal)	75 in.
Image	
Display Format Native Resolution	3,840 x 2,160
Aspect Ratio	16:9
Picture Response Time (Gray to Gray)	8 ms
Refresh Frequency	60 Hz
Pixel Pitch	0.43 mm x 0.43 mm
Pixel Density	59.1 DPI (dots per inch)
Panel Resolution	3,840 x 2,160
Display Colors	1.07 B (10-bit)

Brightness (typical)	350 nits
Contrast Ratio	1,200:1
Viewing Angle	Hor. 178°, Ver. 178°
Backlight Life (estimated)	50,000 hours

## Touch Tracking

Tracking Technology	Touch 360° Infrared
Touch Points Operating Systems	20-touch: Windows 7+ Single touch: Mac OS 10.8+, Linux, Chrome
Touch Tool	Stylus, finger (even if gloved), or solid object
Tracking Accuracy	+/-2mm (0 in.)
Tracking Read Speed	>125 frames/s
Tracking Response Time	12 ms (typical)
Tracking Points	32,767 x 32,767

## Safety

Anti-Glare Glass	Yes
Protective Glass	4 mm tempered glass Level 7 Mohs

## Connections

Input/Output	<p>Input:</p> <ul style="list-style-type: none"> <li>- VGA x 1</li> <li>- HDMI-4K V1.4 x 2</li> <li>- HDMI-4K V2.0 x 1</li> <li>- PC audio x 1</li> <li>- DisplayPort x 1</li> </ul> <p>Output:</p> <ul style="list-style-type: none"> <li>- HDMI x 1</li> <li>- Earphone out x 1</li> <li>- Digital audio output coax x 1</li> </ul> <p>USB:</p> <ul style="list-style-type: none"> <li>- USB 2.0 x 4 (2 in front, 1 on side, 1 on the bottom)</li> <li>- USB 3.0 x 2 (1 in front, 1 on side)</li> </ul>
--------------	---

	<ul style="list-style-type: none"> <li>- USB 2.0 Type-B for touch control (on side)</li> </ul> Control/Network: <ul style="list-style-type: none"> <li>- RJ45/LAN x 1 (bottom)</li> <li>- RS232 x 1 (bottom)</li> </ul>
Audio	
Output	12 W x 2
Sound System	Stereo
Equalizer	Yes
Sound Status Memory	Yes
Balance	Yes
Environmental	
Storage Temperature	-20° to 60° C (-4° to 122° F)
Storage Humidity	10% to 90%
Operating Temperature	0° to 40° C (32° to 104° F)
Operating Humidity	10% to 90%
Power Requirement	100–240 VAC 60/50 Hz
Power Consumption (Operating)	400 W
Power Consumption (Sleep Mode)	<0.5 W
Mount	
Mounting Screw Size	M8 x 25 mm
VESA Form Factor	800 by 400 mm
Accessories	
HDMI Cable	1 x 3 m
AC Power Cable	1 x 3 m

USB Cable	1 x 5 m
Passive Stylus	3 x magnetic
Remote Control	1 (with batteries)
Wall Mount	Optional
Internal PC Module	Optional
<b>Android</b>	
Version	Android 5.1 "Jelly Bean"
CPU	ARM Cortex A53 Dual Core
GPU	Quad Core
RAM	2 GB
ROM	16 GB

## What's in the box:

### Hardware

- Magnetic stylus x 3
- Remote control with batteries

### Documentation

- MimioStudio license
- Warranty card
- QuickStart Guide

### Cables

- HDMI cable (3 m)
- USB A-to-B for touch (5 m)
- US power cord (3 m)

## Drawings

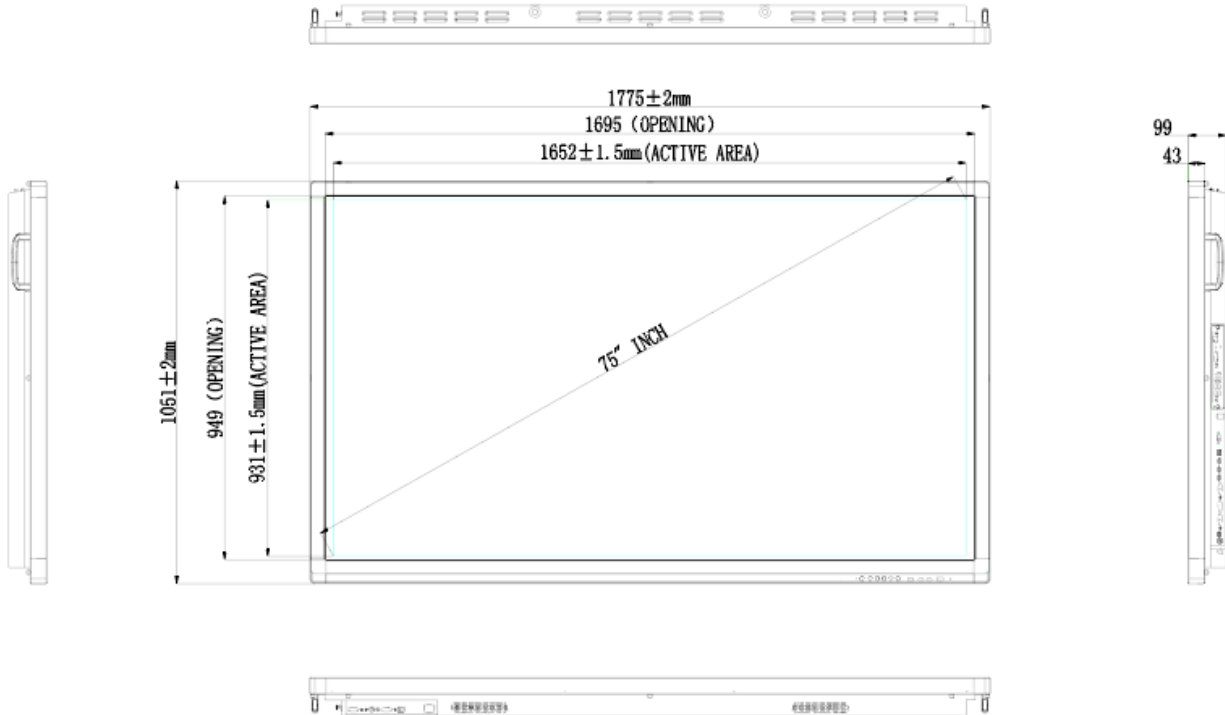

## Connections

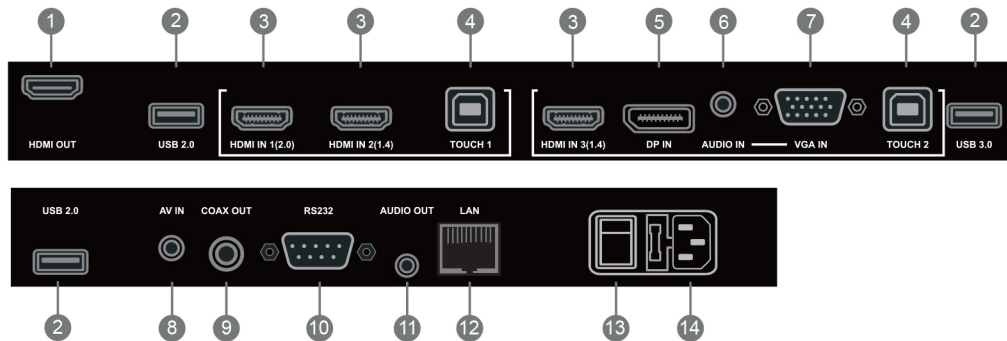

Items	Function description
① HDMI OUT	Displays whatever is on the screen, including Android annotation.
② USB	Connect USB devices such as mobile hard disk, U disk, USB keyboard and mouse, USB drives, etc.
③ HDMI IN	HDMI input
④ TOUCH	Touch signal output for connection to external computer
⑤ DP	DisplayPort input
⑥ AUDIO IN	Line level audio input
⑦ VGA IN	VGA input
⑧ AV IN	Composite video + audio input - 3.5mm 4-conductor
⑨ COAX OUT	Digital audio output - "RCA" connector
⑩ RS-232	Control interface
⑪ AUDIO OUT	Output to an external amplifier and speaker
⑫ LAN	RJ-45 connector
⑬ AC SWITCH	Master power switch
⑭ AC IN	AC power input

HDMI = High-definition multimedia interface

Specifications are subject to change without notice.



Audio•Video•Sales•Design•Service•Installation  
 31805 Temecula Pkwy  
 #224  
 Temecula, CA 92592

Quote Number Q420110293

February 4, 2019

**QUOTED TO**

**TROXELL CONTACT**

Account: Magnolia Public Schools  
 Contact: Rasul Monoshev  
 Address: 250 East First St, Suite 1500  
 Los Angeles, CA 90012

Account Executive: Steven Houser  
 Email: steven.houser@trox.com  
 Phone: (323)333-4285  
 Fax: (818)614-3193

Ref: MSA-1 & MSA-8 interactive displays 2019. product delivery will be within 7 to 10 days after receipt of order and installation will be scheduled for March 15th to March 30th.

Terms Net 30      FOB Destination      Customer # 99999      Expires 05/07/19

Item #	Description	Unit Price	Qty	Ext. Price
1	<b>BXL BXLPROCOLOR652U</b> PROCOLOR 65IN IR UHD/4K ANDROID INTERACTIVE FLAT PANEL 5-YEAR ON-SITE WARRANTY. ALTERNATE TO VIEWSONIC IFP6560.	1725.00	20	34500.00
-----				
2	<b>TRT TRTHOVMOUNT</b> DIVERSITRACK FLAT PANEL MOUNT HEIGHT ADJ 5-YEAR WARRANTY.	384.00	20	7680.00
-----				

Thank You,

Taxable Amount	<b>Subtotal</b>	<b>42180.00</b>
<b>42180.00</b>	@ 9.500 % Tax	<b>4007.10</b>
	<b>Total</b>	<b>46187.10</b>

**Steven Houser**  
**Account Executive**

**Don't forget we are a great source for mounting hardware, screens, replacement lamps, carts, cables, etc...  
 WE CAN HELP YOU ACHIEVE YOUR GOALS!**





Audio•Video•Sales•Design•Service•Installation  
 31805 Temecula Pkwy  
 #224  
 Temecula, CA 92592

Quote Number Q420110294

February 4, 2019

**QUOTED TO**

**TROXELL CONTACT**

Account: Magnolia Public Schools  
 Contact: Rasul Monoshev  
 Address: 250 East First St, Suite 1500  
 Los Angeles, CA 90012

Account Executive: Steven Houser  
 Email: steven.houser@trox.com  
 Phone: (323)333-4285  
 Fax: (818)614-3193

Ref: MSA-1 & MSA-8 interactive displays 2019. product delivery will be within 7 to 10 days after receipt of order and installation will be scheduled for March 15th to March 30th.

Terms Net 30      FOB Destination      Customer # 99999      Expires 05/07/19

Item #	Description	Unit Price	Qty	Ext. Price
1	<b>BXL BXLPROCOLOR752U</b> PROCOLOR 75IN IR UHD/4K ANDROID INTERACTIVE FLAT PANEL 7-YEAR ON-SITE WARRANTY. ALTERNATE TO VIEWSONIC IFP7550.	2239.00	20	44780.00
-----				
2	<b>PMI PMIP5080T</b> TILTING LOW PROFILE FLAT PANEL MOUNT LIFETIME WARRANTY.	118.00	20	2360.00
-----				

Thank You,

Taxable Amount	<b>Subtotal</b>	<b>47140.00</b>
<b>47140.00</b>	@ 9.500 % Tax	<b>4478.30</b>
	<b>Total</b>	<b>51618.30</b>

**Steven Houser**  
**Account Executive**

**Don't forget we are a great source for mounting hardware, screens, replacement lamps, carts, cables, etc...  
 WE CAN HELP YOU ACHIEVE YOUR GOALS!**



Audio•Video•Sales•Design•Service•Installation  
 31805 Temecula Pkwy  
 #224  
 Temecula, CA 92592

Quote Number Q420110295

February 4, 2019

**QUOTED TO**

**TROXELL CONTACT**

Account: Magnolia Public Schools  
 Contact: Rasul Monoshev  
 Address: 250 East First St,Suite 1500  
 Los Angeles, CA 90012

Account Executive: Steven Houser  
 Email: steven.houser@trox.com  
 Phone: (323)333-4285  
 Fax: (818)614-3193

Ref: MSA-1 & MSA-8 interactive displays 2019. product delivery will be within 7 to 10 days after receipt of order and installation will be scheduled for March 15th to March 30th.

Terms Net 30      FOB Destination      Customer # 99999      Expires 05/07/19

Item #	Description	Unit Price	Qty	Ext. Price
1	<b>BXL BXLPROCOLOR652U</b> PROCOLOR 65IN IR UHD/4K ANDROID INTERACTIVE FLAT PANEL 5-YEAR ON-SITE WARRANTY. ALTERNATE TO VIEWSONIC IFP6560.	1725.00	20	34500.00
-----				
2	<b>LUX LUXFP1000</b> ADJUSTABLE HEIGHT ROLLING STAND FOR 65" IFP PRODUCT LIFETIME WARRANTY.	105.00	20	2100.00
-----				

Thank You,

Taxable Amount	<b>Subtotal</b>	<b>36600.00</b>
<b>36600.00</b>	@ 9.500 % Tax	<b>3477.00</b>
	<b>Total</b>	<b>40077.00</b>

**Steven Houser**  
**Account Executive**

**Don't forget we are a great source for mounting hardware, screens, replacement lamps, carts, cables, etc...  
 WE CAN HELP YOU ACHIEVE YOUR GOALS!**



Audio•Video•Sales•Design•Service•Installation  
 31805 Temecula Pkwy  
 #224  
 Temecula, CA 92592

Quote Number Q420110298

February 5, 2019

**QUOTED TO**

**TROXELL CONTACT**

Account: Magnolia Public Schools  
 Contact: Rasul Monoshev  
 Address: 250 East First St,Suite 1500  
 Los Angeles, CA 90012

Account Executive: Steven Houser  
 Email: steven.houser@trox.com  
 Phone: (323)333-4285  
 Fax: (818)614-3193

Ref: MSA-1 & MSA-8 interactive displays 2019. product delivery will be within 7 to 10 days after receipt of order and installation will be scheduled for March 15th to March 30th.

Terms Net 30      FOB Destination      Customer # 99999      Expires 05/08/19

Item #	Description	Unit Price	Qty	Ext. Price
1	<b>BXL BXLPROCOLOR752U</b> PROCOLOR 75IN IR UHD/4K ANDROID INTERACTIVE FLAT PANEL 7-YEAR ON-SITE WARRANTY. ALTERNATE TO VIEWSONIC IFP7550.	2239.00	20	44780.00
2	<b>LUX LUXFP4000</b> ADJUSTABLE HEIGHT ROLLING STAND FOR 75" IFP LIFETIME WARRANTY.	258.00	20	5160.00

Thank You,

Taxable Amount	<b>Subtotal</b>	<b>49940.00</b>
<b>49940.00</b>	@ 9.500 % Tax	<b>4744.30</b>
	<b>Total</b>	<b>54684.30</b>

**Steven Houser**  
**Account Executive**

**Don't forget we are a great source for mounting hardware, screens, replacement lamps, carts, cables, etc...  
 WE CAN HELP YOU ACHIEVE YOUR GOALS!**



Audio•Video•Sales•Design•Service•Installation  
 31805 Temecula Pkwy  
 #224  
 Temecula, CA 92592

Quote Number Q420110299

February 5, 2019

**QUOTED TO**

**TROXELL CONTACT**

Account: Magnolia Public Schools  
 Contact: Rasul Monoshev  
 Address: 250 East First St, Suite 1500  
 Los Angeles, CA 90012

Account Executive: Steven Houser  
 Email: steven.houser@trox.com  
 Phone: (323)333-4285  
 Fax: (818)614-3193

Ref: MSA-1 & MSA-8 interactive displays 2019. product delivery will be within 7 to 10 days after receipt of order and installation will be scheduled for March 15th to March 30th.

Terms Net 30      FOB Destination      Customer # 99999      Expires 05/08/19

Item #	Description	Unit Price	Qty	Ext. Price
1	<b>BXL BXLPROCOLOR652U</b> PROCOLOR 65IN IR UHD/4K ANDROID INTERACTIVE FLAT PANEL 5-YEAR ON-SITE WARRANTY. ALTERNATE TO VIEWSONIC IFP6560.	1725.00	6	10350.00
2	<b>TRT TRTHOVMOUNT</b> DIVERSITRACK FLAT PANEL MOUNT HEIGHT ADJ 5-YEAR WARRANTY.	384.00	6	2304.00

Thank You,

Taxable Amount	<b>Subtotal</b>	<b>12654.00</b>
<b>12654.00</b>	@ 9.500 % Tax	<b>1202.13</b>
	<b>Total</b>	<b>13856.13</b>

**Steven Houser**  
**Account Executive**

**Don't forget we are a great source for mounting hardware, screens, replacement lamps, carts, cables, etc...  
 WE CAN HELP YOU ACHIEVE YOUR GOALS!**



Audio•Video•Sales•Design•Service•Installation  
 31805 Temecula Pkwy  
 #224  
 Temecula, CA 92592

Quote Number Q420110300

February 5, 2019

**QUOTED TO**

**TROXELL CONTACT**

Account: Magnolia Public Schools  
 Contact: Rasul Monoshev  
 Address: 250 East First St,Suite 1500  
 Los Angeles, CA 90012

Account Executive: Steven Houser  
 Email: steven.houser@trox.com  
 Phone: (323)333-4285  
 Fax: (818)614-3193

Ref: MSA-1 & MSA-8 interactive displays 2019. product delivery will be within 7 to 10 days after receipt of order and installation will be scheduled for March 15th to March 30th.

Terms Net 30      FOB Destination      Customer # 99999      Expires 05/08/19

Item #	Description	Unit Price	Qty	Ext. Price
1	<b>BXL BXLPROCOLOR752U</b> PROCOLOR 75IN IR UHD/4K ANDROID INTERACTIVE FLAT PANEL 7-YEAR ON-SITE WARRANTY. ALTERNATE TO VIEWSONIC IFP7550.	2239.00	6	13434.00
-----				
2	<b>PMI PMIP5080T</b> TILTING LOW PROFILE FLAT PANEL MOUNT UP TO 300LBS LIFETIME WARRANTY	118.00	6	708.00
-----				

Thank You,

Taxable Amount	<b>Subtotal</b>	<b>14142.00</b>
<b>14142.00</b>	@ 9.500 % Tax	<b>1343.49</b>
	<b>Total</b>	<b>15485.49</b>

**Steven Houser**  
**Account Executive**

**Don't forget we are a great source for mounting hardware, screens, replacement lamps, carts, cables, etc...  
 WE CAN HELP YOU ACHIEVE YOUR GOALS!**



Audio•Video•Sales•Design•Service•Installation  
 31805 Temecula Pkwy  
 #224  
 Temecula, CA 92592

Quote Number Q420110301

February 5, 2019

**QUOTED TO**

**TROXELL CONTACT**

Account: Magnolia Public Schools  
 Contact: Rasul Monoshev  
 Address: 250 East First St,Suite 1500  
 Los Angeles, CA 90012

Account Executive: Steven Houser  
 Email: steven.houser@trox.com  
 Phone: (323)333-4285  
 Fax: (818)614-3193

Ref: MSA-1 & MSA-8 interactive displays 2019. product delivery will be within 7 to 10 days after receipt of order and installation will be scheduled for March 15th to March 30th.

Terms Net 30      FOB Destination      Customer # 99999      Expires 05/08/19

Item #	Description	Unit Price	Qty	Ext. Price
1	<b>BXL BXLPROCOLOR652U</b> PROCOLOR 65IN IR UHD/4K ANDROID INTERACTIVE FLAT PANEL 5-YEAR ON-SITE WARRANTY. ALTERNATE TO VIEWSONIC IFP6560.	1725.00	6	10350.00
2	<b>LUX LUXFP1000</b> ADJUSTABLE HEIGHT ROLLING STAND FOR 65" IFP LIFETIME WARRANTY.	105.00	6	630.00

Thank You,

**Steven Houser**  
**Account Executive**

**Total** 10980.00  
**Plus Applicable Tax**

**Don't forget we are a great source for mounting hardware, screens, replacement lamps, carts, cables, etc...  
 WE CAN HELP YOU ACHIEVE YOUR GOALS!**



Audio•Video•Sales•Design•Service•Installation  
 31805 Temecula Pkwy  
 #224  
 Temecula, CA 92592

Quote Number Q420110302

February 5, 2019

**QUOTED TO**

**TROXELL CONTACT**

Account: Magnolia Public Schools  
 Contact: Rasul Monoshev  
 Address: 250 East First St,Suite 1500  
 Los Angeles, CA 90012

Account Executive: Steven Houser  
 Email: steven.houser@trox.com  
 Phone: (323)333-4285  
 Fax: (818)614-3193

Ref: MSA-1 & MSA-8 interactive displays 2019. product delivery will be within 7 to 10 days after receipt of order and installation will be scheduled for March 15th to March 30th.

Terms Net 30      FOB Destination      Customer # 99999      Expires 05/08/19

Item #	Description	Unit Price	Qty	Ext. Price
1	<b>BXL BXLPROCOLOR752U</b> PROCOLOR 75IN IR UHD/4K ANDROID INTERACTIVE FLAT PANEL 7-YEAR ON-SITE WARRANTY. ALTERNATE TO VIEWSONIC IFP7550.	2239.00	6	13434.00
-----				
2	<b>LUX LUXFP4000</b> HEIGHT ADJUSTABLE ROLLING STAND FOR 75" IFP LIFETIME WARRANTY.	258.00	6	1548.00
-----				

Thank You,

Taxable Amount	<b>Subtotal</b>	<b>14982.00</b>
<b>14982.00</b>	@ 9.500 % Tax	<b>1423.29</b>
	<b>Total</b>	<b>16405.29</b>

**Steven Houser**  
**Account Executive**

**Don't forget we are a great source for mounting hardware, screens, replacement lamps, carts, cables, etc...  
 WE CAN HELP YOU ACHIEVE YOUR GOALS!**



Audio•Video•Sales•Design•Service•Installation  
 31805 Temecula Pkwy  
 #224  
 Temecula, CA 92592

Quote Number Q420110357

March 6, 2019

**QUOTED TO**

**TROXELL CONTACT**

Account: Magnolia Public Schools  
 Contact: Rasul Monoshev  
 Address: 250 East First St,Suite 1500  
 Los Angeles, CA 90012

Account Executive: Steven Houser  
 Email: steven.houser@trox.com  
 Phone: (323)333-4285  
 Fax: (818)614-3193

Ref: MSA-1 & MSA-8 interactive displays 2019. product delivery will be within 7 to 10 days after receipt of order and installation will be scheduled for March 15th to March 30th.

Terms Net 30      FOB Destination      Customer # 99999      Expires 04/06/19

Item #	Description	Unit Price	Qty	Ext. Price
1	<b>KWI KWIINSTALL00062</b> LABOR TO INSTALL 65" OR 75" INTERACTIVE FLAT PANELS DISPLAYS WALL MOUNT OR ROLLING STAND. 1-YEAR LABOR WARRANTY.	299.00	6	1794.00 Non-Taxable

Thank You,

Taxable Amount	<b>0.00</b>	@ 9.500 % Tax	<b>0.00</b>
<b>Subtotal</b>			<b>1794.00</b>
<b>Total</b>			<b>1794.00</b>

**Steven Houser**  
**Account Executive**

Don't forget we are a great source for mounting hardware, screens, replacement lamps, carts, cables, etc...  
**WE CAN HELP YOU ACHIEVE YOUR GOALS!**





Audio•Video•Sales•Design•Service•Installation  
 31805 Temecula Pkwy  
 #224  
 Temecula, CA 92592

Quote Number Q420110358

March 6, 2019

**QUOTED TO**

**TROXELL CONTACT**

Account: Magnolia Public Schools  
 Contact: Rasul Monoshev  
 Address: 250 East First St,Suite 1500  
 Los Angeles, CA 90012

Account Executive: Steven Houser  
 Email: steven.houser@trox.com  
 Phone: (323)333-4285  
 Fax: (818)614-3193

Ref: MSA-1 & MSA-8 interactive displays 2019. product delivery will be within 7 to 10 days after receipt of order and installation will be scheduled for March 15th to March 30th.

Terms Net 30      FOB Destination      Customer # 99999      Expires 04/06/19

Item #	Description	Unit Price	Qty	Ext. Price
1	<b>KWI KWIINSTALL00062</b> LABOR TO INSTALL 65" OR 75" INTERACTIVE FLAT PANELS DISPLAYS WALL MOUNT OR ROLLING STAND. 1-YEAR LABOR WARRANTY.	299.00	20	5980.00 Non-Taxable

Thank You,

Taxable Amount	<b>Subtotal</b>	<b>5980.00</b>
<b>0.00</b>	@ 9.500 % Tax	<b>0.00</b>
	<b>Total</b>	<b>5980.00</b>

**Steven Houser**  
**Account Executive**

**Don't forget we are a great source for mounting hardware, screens, replacement lamps, carts, cables, etc...  
 WE CAN HELP YOU ACHIEVE YOUR GOALS!**



To: Magnolia Public Schools  
From: Patrick Ontiveros, MPS General Counsel  
Date: March 13, 2018

RE: Approval to grant winning bid for Staples, Digital Synergy – Viewsonic interactive display for wall mount, on mobile cart options and the labor for installation.

Magnolia Public Schools (MPS) Chief Executive Officer and MPS General Counsel acknowledge that they have read and reviewed the bid details pertaining to the above matter.

A handwritten signature in blue ink that reads "Patrick Ontiveros".

Patrick Ontiveros  
MPS General Counsel

A handwritten date in blue ink that reads "3/15/2015".

Date

A handwritten signature in black ink that reads "Alfredo Rubalcava".

Alfredo Rubalcava  
MPS CEO & Superintendent

A handwritten date in black ink that reads "3/15/2015".

Date