



Ivy Hill Prep Charter School

Board of Trustees Meeting - Ivy Hill Prep

Amended on January 21, 2020 at 9:50 PM EST

Date and Time

Monday January 27, 2020 at 6:30 PM EST

Location

Ivy Hill Prep Charter School, 475 East 57th Street, Marital Arts Room, Brooklyn NY - CALL 201-785-7737 to ENTER SCHOOL

IVY HILL PREP - BOARD OF TRUSTEES

Agenda

	Purpose	Presenter	Time
I. Opening Items			6:30 PM
Opening Items			
A. Call the Meeting to Order		Marsha Michael	
Welcome Guests/Public Comments			
B. Record Attendance and Guests		Kimberly Wedderburn-Henderson	1 m
C. Approve Minutes	Approve Minutes	Kimberly Wedderburn-Henderson	4 m
Approve minutes for Board of Trustees Meeting - Ivy Hill Prep on October 28, 2019			
D. Approve Minutes from November Meeting	Vote	Marsha Michael	5 m
E. Vote to Approve Agenda	Vote	Marsha Michael	2 m
II. Head of School Evaluation & Support Committee			6:42 PM
CEO Support And Eval			
A. Discuss Ongoing Support	Discuss	Marsha Michael	10 m
III. Finance Committee			6:52 PM
Finance			

A. Review Financial Dashboard for Month Ending November 2019 & December 2019	Discuss	Nataki Williams	15 m
B. Vote to Approve Amended Year 1 Budget	Vote	Nataki Williams	5 m
Vote to Approve Amended Budget Line Item to increase Teacher/Staff Appreciation to \$10K. Budget Attached as an Excel Document			
IV. Governance			7:12 PM
Governance			
A. Vote to Approve Staff Resignation Policy	Vote	Marsha Michael	5 m
B. Vote to Approve Adding 3 New Trustees to Board of Trustee	Vote	Marsha Michael	3 m
C. Discuss Recruiting New Trustees and Succession Planning	Discuss	Marsha Michael	2 m
D. Vote to Approve 2020 Board Meeting & Committee Meeting Calendar	Vote	Marsha Michael	5 m
V. Development			7:27 PM
Development			
A. Vote to Approve Development Goal	Vote	Marsha Michael	5 m
B. Discuss Development Initiatives	Discuss	Tanisha James	10 m
<ul style="list-style-type: none"> • Discuss Plan for Trivia/Game Night • Discuss Silent Auction 			
VI. Academic Achievement			7:42 PM
Academic Achievement			
A. Review Academic Dashboard	Discuss	Marsha Michael	13 m
B. Review IHP Academic Philosophy	Discuss		5 m
VII. Facilities Update			8:00 PM
A. Vote to Approve 3rd Floor Renovation Plan and Bid	Vote	Ambrosia Johnson/ Brandon Parker	20 m
B. Vote to Approve Maintenance Overhaul	Vote	Ambrosia Johnson/ Brandon Parker	10 m
<ul style="list-style-type: none"> • Vote to Approve Terminating Current Janitorial Contract • Vote to Approve Management's Maintenance Overhaul Proposal • Vote to Approve Facilities Support Associate Job Description 			
VIII. Head of School Update			8:30 PM
A. HOS Report	Discuss	Ambrosia Johnson	20 m
IX. Closing Items			8:50 PM
A. Meeting Evaluation	Discuss	Adam Laniyan	5 m
B. Adjourn Meeting	Vote	Marsha Michael	

Cover Sheet

Approve Minutes

Section: I. Opening Items
Item: C. Approve Minutes
Purpose: Approve Minutes
Submitted by:
Related Material: Minutes for Board of Trustees Meeting - Ivy Hill Prep on October 28, 2019

DRAFT

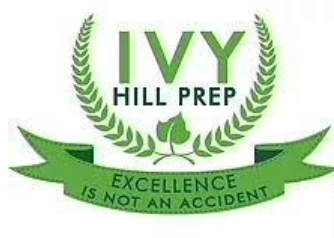

Ivy Hill Prep Charter School

Minutes

Board of Trustees Meeting - Ivy Hill Prep

Date and Time

Monday October 28, 2019 at 6:30 PM

Location

Ivy Hill Prep Charter School, 475 East 57th Street, Marital Arts Room, Brooklyn NY - CALL 201-785-7737 to ENTER SCHOOL

IVY HILL PREP - BOARD OF TRUSTEES
OCTOBER 2019 BOARD MEETING

Directors Present

A. Jimenez-Schulman (remote), D. Lewis (remote), J. Small, K. Wedderburn-Henderson, M. Michael, N. Williams

Directors Absent

None

Guests Present

A. Johnson, A. Laniyan (remote), M. Kane

I. Opening Items

A. Call the Meeting to Order

M. Michael called a meeting of the board of directors of Ivy Hill Prep Charter School to order on Monday Oct 28, 2019 @ 6:38 PM at Ivy Hill Prep Charter School, 475 East 57th Street, Marital Arts Room, Brooklyn NY - CALL 201-785-7737 to ENTER SCHOOL.

B. Record Attendance and Guests

C. Approve Minutes

M. Michael made a motion to approve minutes from the Board of Trustees Meeting - Ivy Hill Prep on 09-30-19. Board of Trustees Meeting - Ivy Hill Prep on 09-30-19

N. Williams seconded the motion.

The board **VOTED** to approve the motion.

Roll Call

K. Wedderburn-Henderson	Aye
M. Michael	Aye
A. Jimenez-Schulman	Aye
J. Small	Abstain
D. Lewis	No
N. Williams	Aye

M. Michael made a motion to approve minutes from the Board of Trustees Meeting - Ivy Hill Prep on 09-30-19. Board of Trustees Meeting - Ivy Hill Prep on 09-30-19

N. Williams seconded the motion.

The board **VOTED** to approve the motion.

Roll Call

A. Jimenez-Schulman	Aye
J. Small	Abstain
K. Wedderburn-Henderson	Aye
D. Lewis	Absent
N. Williams	Aye
M. Michael	Aye

II. Head of School Evaluation & Support Committee

A. Discuss and Vote to Approve HOS Evaluation for Planning Year

The overarching goal of the Head of School Evaluation is to foster dialogue between the Board and Ambrosia Johnson. The Board discussed the committee findings.

N. Williams made a motion to Approve Head of School Evaluation.

K. Wedderburn-Henderson seconded the motion.

The board **VOTED** unanimously to approve the motion.

B. Discuss Plan for Year 1 Evaluation Process & Timeline

C. HOS Goals for Year 1

This will be discussed at a later date. Board Chair and HOS are still discussing goals.

III. Finance Committee

A. Review Financial Dashboard for September YTD

The Board reviewed the amended Year 1 Budget. A discussion ensued around the various amendments with the Treasurer reporting on the finance committee's recommendations. There was a discussion surrounding the capital budget and the need to time expenses to ensure there was an appropriate amount of cash flow. There was also a discussion surrounding the capital budget being contingent upon management timing expenditures within the necessary time frame for reimbursement from the CSP grant.

The Board also discussed funding for students with IEPs. The Board questioned whether Ivy Hill Prep would be eligible for additional funding for students who receive special education services, even if they are not taught by certified special education teachers. HOS stated that as long as the classroom teacher is certified, the school will receive the additional funding. Mrs. Johnson received this information with the Authorizer.

B. Vote to Approve Amended Year 1 Budget

N. Williams made a motion to Approve Year 1 Budget.

K. Wedderburn-Henderson seconded the motion.

The board **VOTED** unanimously to approve the motion.

Roll Call

M. Michael	Aye
D. Lewis	Absent
J. Small	Aye
N. Williams	Aye
A. Jimenez-Schulman	Aye
K. Wedderburn-Henderson	Aye

IV. Governance

A. Vote to Approve Board Vetting & Recruitment Policy

M. Michael made a motion to Approve.

K. Wedderburn-Henderson seconded the motion.

The board **VOTED** unanimously to approve the motion.

Roll Call

M. Michael	Aye
K. Wedderburn-Henderson	Aye
A. Jimenez-Schulman	Aye
J. Small	Aye
N. Williams	Aye

B. Vote to Approve On-Boarding Policy

Same

M. Michael made a motion to Vote to Approve On-Boarding Policy.

K. Wedderburn-Henderson seconded the motion.

The board **VOTED** unanimously to approve the motion.

C. Discuss Board Development & Webinar Schedule

The Board reviewed the results of the board assessment and focused specifically on the weak areas. Board Chair Marsha Michael suggested scheduling a webinar viewing as well as an in-person training. The Board will schedule these two events this month.

D. Confirm Attendance for Board Mixer November 10, 2019

V. Development

A. Discuss Development Committee Action Plan

The Development Committee has developed an action plan to raise \$10,000. The goal is to use these funds to fix student bathrooms on the second floor. The Development Committee is also planning to provide backpacks and supplies for all scholars by September 2020.

The Board is currently planning a toy drive for December 19. The Scholars will write holiday wish list letters and the Board will partner with a corporate sponsor to provide toys for all of them.

VI. Academic Achievement

A. Review Academic Dashboard

The Board reviewed the current Academic Assessments. The first math interim assessment will be added to the Dashboard by the next Board Meeting.

VII. Head of School Update

A. HOS Report

The 2020-2021 application went live on October 1. There will be open houses once per week for prospective parents. HOS also plans to reengage all of the preschools she worked with last year.

The Baseline Reading Assessment from the beginning of the year revealed that 60% students were performing below grade level. Now, two months into the school year, that number has dropped to 15%. This shows that the majority of students have made significant progress in reading. The results from the Math Interim Assessment will be available at the next meeting.

VIII. Closing Items

A. Meeting Evaluation

Board Member Jennifer Small evaluated the Board Meeting. She noted that all of the items on the agenda were discussed and the meeting still ended on time. She also suggested that all the meeting materials be made available prior to the board meeting as HOS passed out new information during the course of the meeting.

B. Adjourn Meeting

M. Michael made a motion to adjourn the meeting.

J. Small seconded the motion.

The board **VOTED** unanimously to approve the motion.

Roll Call

A. Jimenez-Schulman Aye

J. Small Aye

N. Williams Aye

M. Michael Aye

K. Wedderburn-Henderson Aye

There being no further business to be transacted, and upon motion duly made, seconded and approved, the meeting was adjourned at 8:30 PM.

Respectfully Submitted,
M. Michael

IX. Certification of the Secretary

A. Certification of Minutes

The undersigned does hereby certify that the undersigned is the Secretary of the Corporation an education Corporation duly organized and existing under the law of the State of New

York; and that the Meeting Minutes of said Corporation were duly and regularly adopted as such by the Board of Trustees of said Corporation.

Secretary: Kimberly Wedderburn-Henderson

Date: November 25, 2019

Cover Sheet

Approve Minutes from November Meeting

Section: I. Opening Items
Item: D. Approve Minutes from November Meeting
Purpose: Vote
Submitted by:
Related Material: November Board Meeting Minutes for Approval - no Quorum.pdf

DRAFT

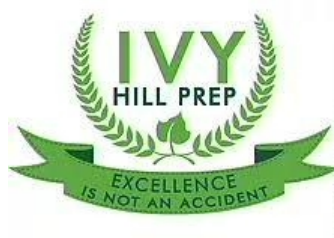

Ivy Hill Prep Charter School

Minutes

Board of Trustees Meeting - Ivy Hill Prep

Date and Time

Monday November 25, 2019 at 6:30 PM

Location

Ivy Hill Prep Charter School, 475 East 57th Street, Marital Arts Room, Brooklyn NY - CALL 201-785-7737 to ENTER SCHOOL

IVY HILL PREP - BOARD OF TRUSTEES
NOVEMBER 2019 BOARD MEETING

Directors Present

J. Small, M. Michael, N. Williams

Directors Absent

A. Jimenez-Schulman, D. Lewis, K. Wedderburn-Henderson

Guests Present

T. James

I. Opening Items**A. Call the Meeting to Order**

Meeting called to order at 6:39pm

B. Record Attendance and Guests**C. Approve Minutes**

Vote Tabled as there was not quorum for the vote.

D. Vote to Approve Agenda

Vote Tabled as there was not quorum for the vote.

II. Head of School Evaluation & Support Committee

A. Discuss Evaluation Meeting w/HOS

Committee provided HOS with finalized board approved evaluation on November 22, 2019. Committee discussed next steps for support going forward.

B. Discuss Next Steps in Process

Discussion that committee would do ongoing support keeping in line with 12 month evaluation time frame.

III. Finance Committee

A. Vote to Approve Amended Year 1 Budget

Vote tabled as there was not quorum necessary for a vote.

B. Review Financial Dashboard for Month Ending October 2019

Committee reviewed financial data

IV. Governance

A. Vote to Approve Staff Resignation Policy

Vote tabled as there was not quorum necessary for a vote.

B. Discuss Updates on Continued Board Development

C. Discuss Adding New Trustees and Succession Planning

D. Discuss Electrical Issue with Nazareth

Board Chair spoke with board chair from Nazareth regarding looking into the issue and Nazareth will get back to Board Chair as to where issue may be.

E. Discuss December Board Meeting Date

V. Development

A. Vote to Approve Development Goal

Vote tabled as there was not quorum necessary for a vote.

B. Discuss Development Initiatives

Giving Tuesday initiative discussed.

VI. Head of School Update

A. HOS Report

HOS provided detailed discussion regarding improvements made in assessment results by scholars.

VII. Closing Items

A. Meeting Evaluation

B. Adjourn Meeting

Meeting adjourned at 8:08pm - No Vote taken to adjourn meeting as quorum not present. There being no further business to be transacted, and upon motion duly made, seconded and approved, the meeting was adjourned at 8:09 PM.

Respectfully Submitted,
M. Michael

Documents used during the meeting

- Ivy Hill Financial Report for Period Ending 10.31.19 (1).pdf
- Employee Resignation Policy.pdf
- Board of Trustees-Bylaws Provisionsvf.pdf
- 2019 Development Goal Resolution.pdf
- Giving Tuesday.1.pdf
- Giving Tuesday.2.pdf
- Giving Tuesday.3.pdf
- Giving Tuesday.4.pdf
- Giving Tuesday.5.pdf
- Academic Dashboard - November.pdf
- Head of School Report_November.docx
- Board Meeting Evaluation.docx

Cover Sheet

Discuss Ongoing Support

Section: II. Head of School Evaluation & Support Committee
Item: A. Discuss Ongoing Support
Purpose: Discuss
Submitted by:
Related Material: 12 Month Work Plan for Evaluation Process.pdf



HEAD OF SCHOOL EVALUATION TIMELINE

12 Month Evaluation Plan		
Month	Task	Completed Yes/NO
July	Finish HOS Evaluation <ul style="list-style-type: none"> Committee Chair shares evaluation survey with Board Committee Chair drafts summary of evaluation process Committee Chair shares summary and evaluation details with Board. Committee Chair and HOS review memo and collaborate to refine HOS goals and introduce HOS personal development goals for upcoming year. 	
August	<ul style="list-style-type: none"> Committee collaborates with HOS to define goals against which to measure HOS performance in Year 1. HOS and committee create HOS development plan. Board approves the goals that HOS and Committee developed. 	
September	<ul style="list-style-type: none"> HOS report on progress toward goals to Committee Committee Chair works with HOS to set dates for December and March check-ins and June end of year evaluation 	
October	<ul style="list-style-type: none"> HOS reports on progress towards goals to Committee 	

*Through high-quality curriculum and instruction, intentional leadership development, and a commitment to excellence in all that we do, **Ivy Hill Preparatory Charter School** educates kindergarten through fifth grade scholars to thrive in middle and high school, graduate from the college of their choice, and access lives of purpose and opportunity.*



HEAD OF SCHOOL EVALUATION TIMELINE

12 Month Evaluation Plan		
Month	Task	Completed Yes/NO
November	<ul style="list-style-type: none"> HOS reports on progress towards goals to Committee HOS completes self-reflection on goals. Committee Chair plans December check-in meeting Committee works with HOS to have staff satisfaction survey 	
December	<ul style="list-style-type: none"> HOS reports on progress towards goals to Committee Committee conducts structured check-in with HOS before winter break and what is working /not working with BOARD/HOS partnership 	
January	<ul style="list-style-type: none"> HOS reports on progress towards goals to Committee Committee Chair reports t board regarding December check-in 	
February	<ul style="list-style-type: none"> HOS reports on progress towards goals to Committee HOS completes self reflection Committee Chair plans March check-in conversation Committee Chair works with HOS to have parent satisfaction survey completed. 	
March	<ul style="list-style-type: none"> HOS reports on progress towards goals to Committee Committee conducts structured check-in with HOS before winter break and what is working /not working with BOARD/HOS partnership 	

*Through high-quality curriculum and instruction, intentional leadership development, and a commitment to excellence in all that we do, **Ivy Hill Preparatory Charter School** educates kindergarten through fifth grade scholars to thrive in middle and high school, graduate from the college of their choice, and access lives of purpose and opportunity.*



HEAD OF SCHOOL EVALUATION TIMELINE

12 Month Evaluation Plan		
Month	Task	Completed Yes/NO
April	<ul style="list-style-type: none"> HOS reports on progress towards goals to Committee Committee Chair reports t board regarding March check-in Committee Chair plans end of year CEO evaluation 	
May	<ul style="list-style-type: none"> HOS reports on progress towards goals to Committee 	
June	<p>Committee Conduct end of year HOS evaluation</p> <ul style="list-style-type: none"> HOS completes evaluation Direct reports (DOO) completes evaluation Committee completes evaluation 	

*Through high-quality curriculum and instruction, intentional leadership development, and a commitment to excellence in all that we do, **Ivy Hill Preparatory Charter School** educates kindergarten through fifth grade scholars to thrive in middle and high school, graduate from the college of their choice, and access lives of purpose and opportunity.*

Cover Sheet

Review Financial Dashboard for Month Ending November 2019 & December 2019

Section: III. Finance Committee
Item: A. Review Financial Dashboard for Month Ending November 2019 & December 2019
Purpose: Discuss
Submitted by:
Related Material: Ivy Hill Monthly Financials - December 2019 (1).xlsx
Ivy Hill Monthly Financials - November 2019 (12.16.19).xlsx

Cover Sheet

Vote to Approve Amended Year 1 Budget

Section: III. Finance Committee
Item: B. Vote to Approve Amended Year 1 Budget
Purpose: Vote
Submitted by:
Related Material: Final Budget Approved on 11-25-19.xlsx

Cover Sheet

Vote to Approve Staff Resignation Policy

Section: IV. Governance
Item: A. Vote to Approve Staff Resignation Policy
Purpose: Vote
Submitted by:
Related Material: Resignation Policy.pdf



IVY HILL PREP BOARD OF TRUSTEES EMPLOYEE RESIGNATION POLICY

Employee Resignation (All Staff/Administrators)

If an employee elects to resign from their position, for any reason, the employee must provide the School with written notice of their intent to resign, at minimum, two (2) weeks prior to the effective date of their intended resignation.

In addition to providing written notice at minimum two (2) weeks prior to the effective date of the resignation, the Employee must also strictly adhere to the following transitional steps:

1. Surrender all keys used to gain access to the School and any locked rooms therein.
2. Surrender all computer equipment, including but not limited to laptops/tablets.
3. Disclose all password used in connection with employment at the School.
4. Ensure the proper transition of any projects by informing the School of the contact information of anyone involved in the project, current status of the project and any next steps necessary to complete the project.
5. Follow all necessary steps to ensure an effective transition of work-related responsibilities.

Failure to strictly abide by the notice requirement and/or failure to follow the steps noted above to facilitate an effective transition of the Employee's duties will result in the automatic forfeiture of any accrued paid time off and forfeiture of any other additional benefits deemed appropriate by the School.

*Through high-quality curriculum and instruction, intentional leadership development, and a commitment to excellence in all that we do, **Ivy Hill Preparatory Charter School** educates kindergarten through fifth grade scholars to thrive in middle and high school, graduate from the college of their choice, and access lives of purpose and opportunity.*

Cover Sheet

Vote to Approve Adding 3 New Trustees to Board of Trustee

Section: IV. Governance
Item: B. Vote to Approve Adding 3 New Trustees to Board of Trustee
Purpose: Vote
Submitted by:
Related Material: Resolution Adding ADAM LANIYAN as BM.pdf
Resolution Adding Maimouna Kane as BM.pdf
Resolution Adding TANISHA JAMES as BM.pdf



IVY HILL PREPARATORY CHARTER SCHOOL

Board of Directors

Kimberly Wedderburn-Henderson,
Secretary
Derrick Lewis
Marsha D. Michael, *Board Chair*
Adam Jimenez-Schulman
Nataki Williams, *Treasurer*
Jennifer Small

Head of School

Ambrosia Johnson

Director of Operations

Brandon Parker

RESOLUTION APPROVING ADAM LANIYAN AS TRUSTEE MEMBER

*The Ivy Hill Preparatory Charter School Board of Trustees, having conducted a thorough background check via a fingerprint scan as required and having discovered no State or federal criminal history, has voted to select **ADAM LANIYAN** as a final candidate to its Board of Trustees, with a term expiring on July, 2022 pending approval by NYSED. The resolution approving **ADAM LANIYAN** is formally adopted upon NYSED's approval.*

**Adopted by Ivy Hill Prep's Board of Trustees on January 27, 2020
(By a Unanimous Vote of The Majority of the Board).**

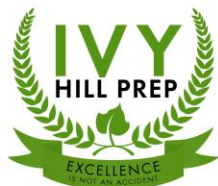

IVY HILL PREPARATORY CHARTER SCHOOL

Board of Directors

Kimberly Wedderburn-Henderson,
Secretary
Derrick Lewis
Marsha D. Michael, *Board Chair*
Adam Jimenez-Schulman
Nataki Williams, *Treasurer*
Jennifer Small

Head of School

Ambrosia Johnson

Director of Operations

Brandon Parker

RESOLUTION APPROVING MAIMOUNA KANE AS TRUSTEE MEMBER

*The Ivy Hill Preparatory Charter School Board of Trustees, having conducted a thorough background check via a fingerprint scan as required and having discovered no State or federal criminal history, has voted to select **MAIMOUNA KANE** as a final candidate to its Board of Trustees, with a term expiring on July, 2022 pending approval by NYSED. The resolution approving **MAIMOUNA KANE** is formally adopted upon NYSED's approval.*

**Adopted by Ivy Hill Prep's Board of Trustees on January 27, 2020
(By a Unanimous Vote of The Majority of the Board).**



IVY HILL PREPARATORY CHARTER SCHOOL

Board of Directors

Kimberly Wedderburn-Henderson,
Secretary
Derrick Lewis
Marsha D. Michael, *Board Chair*
Adam Jimenez-Schulman
Nataki Williams, *Treasurer*
Jennifer Small

Head of School

Ambrosia Johnson

Director of Operations

Brandon Parker

RESOLUTION APPROVING TANISHA JAMES AS TRUSTEE MEMBER

*The Ivy Hill Preparatory Charter School Board of Trustees, having conducted a thorough background check via a fingerprint scan as required and having discovered no State or federal criminal history, has voted to select **TANISHA JAMES** as a final candidate to its Board of Trustees, with a term expiring on July, 2021 pending approval by NYSED. The resolution approving **TANISHA JAMES** is formally adopted upon NYSED's approval.*

**Adopted by Ivy Hill Prep's Board of Trustees on January 27, 2020
(By a Unanimous Vote of The Majority of the Board).**

Cover Sheet

Vote to Approve 2020 Board Meeting & Committee Meeting Calendar

Section: IV. Governance
Item: D. Vote to Approve 2020 Board Meeting & Committee Meeting Calendar
Purpose: Vote
Submitted by:
Related Material: Board Committee Meetings Calendar 2020.pdf



**IVY HILL PREPARTORY CHARTER SCHOOL
BOARD OF TRUSTEES STANDING MONTHLY MEETING CALENDAR & COMMITTEE CALENDAR**

Ivy Hill Prep Charter School, 475 East 57th Street, Martial Arts Room, Brooklyn, NY 11203

(Call/Text: 201-785-7737 for Access to School on Meeting Date)

ZOOM DIAL IN: <https://zoom.us/j/9699543901>

Board Meeting Dates	Standing Date & Time:	Location:
1. January 27th, 2020	<i>Standing Meeting Changed to Last Monday of the Month</i> Time: 6:30pm – 8:30pm	Ivy Hill Prep
2. February 24th, 2020	Time: 6:30pm – 8:30pm	Ivy Hill Prep
3. March 30 th , 2020	Time: 6:30pm – 8:30pm	Ivy Hill Prep
4. April 27 th , 2020	Time: 6:30pm – 8:30pm	Ivy Hill Prep
5. May 25 th , 2020	Time: 6:30pm – 8:30pm	Ivy Hill Prep
6. June 29 th , 2020	Time: 6:30pm – 8:30pm	Ivy Hill Prep
7. July 27 th , 2020	Time: 6:30pm – 8:30pm	Ivy Hill Prep
8. August 31 st , 2020	Time: 6:30pm – 8:30pm	Ivy Hill Prep
9. September 28 th 2020	Time: 6:30pm – 8:30pm	Ivy Hill Prep
10. October 26 th , 2020	Time: 6:30pm – 8:30pm	Ivy Hill Prep
11. November 30 th , 2020	Time: 6:30pm – 8:30pm	Ivy Hill Prep
12. December 28 th , 2020	Time: 6:30pm – 8:30pm	Ivy Hill Prep

**Trustee Member Adam Jimenez- Schulman started attending meetings via videoconference (zoom) from Pierre Lallementstraat | 1097 JR | Amsterdam, Netherlands*

Academic Achievement Comm. Meeting Date: Committee Members: Marsha, Adam, Kimberly	Standing Date & Time: 4th Wed of Every Month Time: 8:00pm – 8:30pm	ZOOM DIAL IN: https://zoom.us/j/9699543901
13. January 08 th , 2020	<i>Standing Meeting Changed to 2nd Wednesday of the Month</i> 8:00pm – 8:30pm	Ivy Hill Prep
14. February 12 th , 2020	Time: 6:30pm – 8:30pm	Ivy Hill Prep
15. March 11 th , 2020	Time: 6:30pm – 8:30pm	Ivy Hill Prep
16. April 08 th , 2020	Time: 6:30pm – 8:30pm	Ivy Hill Prep
17. May 13 th , 2020	Time: 6:30pm – 8:30pm	Ivy Hill Prep
18. June 10 th , 2020	Time: 6:30pm – 8:30pm	Ivy Hill Prep
19. July 08 th , 2020	Time: 6:30pm – 8:30pm	Ivy Hill Prep
20. August 12 th , 2020	Time: 6:30pm – 8:30pm	Ivy Hill Prep
21. September 09 th 2020	Time: 6:30pm – 8:30pm	Ivy Hill Prep
22. October 07 th , 2020	Time: 6:30pm – 8:30pm	Ivy Hill Prep
23. November 11 th , 2020	Time: 6:30pm – 8:30pm	Ivy Hill Prep
24. December 09 th , 2020	Time: 6:30pm – 8:30pm	Ivy Hill Prep

Through high-quality curriculum and instruction, intentional leadership development, and a commitment to excellence in all that we do, Ivy Hill Preparatory Charter School educates kindergarten through fifth grade scholars to thrive in middle and high school, graduate from the college of their choice, and access lives of purpose and opportunity.



**IVY HILL PREPARTORY CHARTER SCHOOL
BOARD OF TRUSTEES STANDING MONTHLY MEETING CALENDAR & COMMITTEE CALENDAR**

Ivy Hill Prep Charter School, 475 East 57th Street, Martial Arts Room, Brooklyn, NY 11203

(Call/Text: 201-785-7737 for Access to School on Meeting Date)

ZOOM DIAL IN: <https://zoom.us/j/9699543901>

Finance Committee Meeting Date Committee Members: Nataki (Chair), Derrick, Adam, Jennifer, Marsha (ex-officio)	Standing Date & Time: 3 rd Monday of Every Month Time: 5:00 pm – 6:00pm	ZOOM DIAL IN: https://zoom.us/j/9699543901
25. January 20 th , 2020	<i>Standing Meeting Changed to 3rd Monday of the Month</i> 6:30 pm – 7:30pm	Ivy Hill Prep
26. February 17 th , 2020	Time: 6:30pm – 7:30pm	Ivy Hill Prep
27. March 16 th , 2020	Time: 6:30pm – 7:30pm	Ivy Hill Prep
28. April 20 th , 2020	Time: 6:30pm – 7:30pm	Ivy Hill Prep
29. May 18 th , 2020	Time: 6:30pm – 7:30pm	Ivy Hill Prep
30. June 15 th , 2020	Time: 6:30pm – 7:30pm	Ivy Hill Prep
31. July 20 th , 2020	Time: 6:30pm – 7:30pm	Ivy Hill Prep
32. August 17 th , 2020	Time: 6:30pm – 7:30pm	Ivy Hill Prep
33. September 21 th 2020	Time: 6:30pm – 7:30pm	Ivy Hill Prep
34. October 19 th , 2020	Time: 6:30pm – 7:30pm	Ivy Hill Prep
35. November 16 th , 2020	Time: 6:30pm – 7:30pm	Ivy Hill Prep
36. December 21 th , 2020	Time: 6:30pm – 7:30pm	Ivy Hill Prep

Governance Committee Meeting Date Committee Members: Marsha (Chair), Derrick, Kimberly	Standing Date & Time: 1 st Tues of Every Month Time: 8:00pm – 8:30pm	ZOOM DIAL IN: https://zoom.us/j/9699543901
1. January 7 th , 2020	Time: 8:00pm – 8:30pm	Ivy Hill Prep
2. February 04 th , 2020	Time: 8:00pm – 8:30pm	Ivy Hill Prep
3. March 03 rd , 2020	Time: 8:00pm – 8:30pm	Ivy Hill Prep
4. April 07 th , 2020	Time: 8:00pm – 8:30pm	Ivy Hill Prep
5. May 5 th , 2020	Time: 8:00pm – 8:30pm	Ivy Hill Prep
6. June 2 nd , 2020	Time: 8:00pm – 8:30pm	Ivy Hill Prep
7. July 7 th , 2020	Time: 8:00pm – 8:30pm	Ivy Hill Prep
8. August 4 th , 2020	Time: 8:00pm – 8:30pm	Ivy Hill Prep
9. September 1 st , 2020	Time: 8:00pm – 8:30pm	Ivy Hill Prep
10. October 6 th , 2020	Time: 8:00pm – 8:30pm	Ivy Hill Prep
11. November 3 rd , 2020	Time: 8:00pm – 8:30pm	Ivy Hill Prep
12. December 1st, 2020	Time: 8:00pm – 8:30pm	Ivy Hill Prep

*Through high-quality curriculum and instruction, intentional leadership development, and a commitment to excellence in all that we do, **Ivy Hill Preparatory Charter School** educates kindergarten through fifth grade scholars to thrive in middle and high school, graduate from the college of their choice, and access lives of purpose and opportunity.*



**IVY HILL PREPARTORY CHARTER SCHOOL
BOARD OF TRUSTEES STANDING MONTHLY MEETING CALENDAR & COMMITTEE CALENDAR**

Ivy Hill Prep Charter School, 475 East 57th Street, Martial Arts Room, Brooklyn, NY 11203

(Call/Text: 201-785-7737 for Access to School on Meeting Date)

ZOOM DIAL IN: <https://zoom.us/j/9699543901>

Development Committee Meeting Date Committee Members: Nataki, Derrick, Jennifer, Marsha	Standing Date & Time: 2 nd Monday of the Month Time: 8:30pm-9:00pm	ZOOM DIAL IN: https://zoom.us/j/9699543901
13. January 13 th , 2020	Time: 8:30pm-9:00pm	Ivy Hill Prep
14. February 10 th , 2020	Time: 8:30pm-9:00pm	Ivy Hill Prep
15. March 09 th , 2020	Time: 8:30pm-9:00pm	Ivy Hill Prep
16. April 13 th , 2020	Time: 8:30pm-9:00pm	Ivy Hill Prep
17. May 11 th , 2020	Time: 8:30pm-9:00pm	Ivy Hill Prep
18. June 8 th , 2020	Time: 8:30pm-9:00pm	Ivy Hill Prep
19. July 13 th , 2020	Time: 8:30pm-9:00pm	Ivy Hill Prep
20. August 10 th , 2020	Time: 8:30pm-9:00pm	Ivy Hill Prep
21. September 14 th , 2020	Time: 8:30pm-9:00pm	Ivy Hill Prep
22. October 12 th , 2020	Time: 8:30pm-9:00pm	Ivy Hill Prep
23. November 9 th , 2020	Time: 8:30pm-9:00pm	Ivy Hill Prep
24. December 14 th , 2020	Time: 8:30pm-9:00pm	Ivy Hill Prep

***Dates subject to change due to holiday**

*Through high-quality curriculum and instruction, intentional leadership development, and a commitment to excellence in all that we do, **Ivy Hill Preparatory Charter School** educates kindergarten through fifth grade scholars to thrive in middle and high school, graduate from the college of their choice, and access lives of purpose and opportunity.*

Cover Sheet

Vote to Approve Development Goal

Section: V. Development
Item: A. Vote to Approve Development Goal
Purpose: Vote
Submitted by:
Related Material: 2019-2020 Development Resolution Goal.pdf

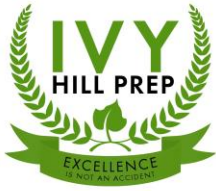

IVY HILL PREPARATORY CHARTER SCHOOL

Board of Directors

Kimberly Wedderburn-Henderson,
Secretary
Derrick Lewis
Marsha D. Michael, *Board Chair*
Adam Jimenez-Schulman
Jennifer Small
Nataki Williams, *Treasurer*

Head of School

Ambrosia Johnson

Director of Operations

Brandon Parker

RESOLUTION APPROVING DEVELOPMENT GOAL

The Ivy Hill Preparatory Charter School Board of Trustees, having considered all necessary concerns has voted to approve a Development Goal of raising \$10,000 (ten thousand dollars) by the end of the fiscal year ending June 30, 2020.

Adopted by Ivy Hill Prep's Board of Trustees on January 27, 2020
(By a Unanimous Vote of The Majority of the Board).

Cover Sheet

Review Academic Dashboard

Section: VI. Academic Achievement
Item: A. Review Academic Dashboard
Purpose: Discuss
Submitted by:
Related Material: Academic Dashboard October 2019 - Jan 2020.xlsx

Cover Sheet

Review IHP Academic Philosophy

Section: VI. Academic Achievement
Item: B. Review IHP Academic Philosophy
Purpose: Discuss
Submitted by:
Related Material: IHP_Academic Philisophy_19-20.pdf



Ivy Hill Preparatory Charter School Academic Philosophy

Ivy Hill Prep's instructional design is rooted in the successful practices and research of high performing charter schools across the country. At Ivy Hill Prep, we realize that to drive academic achievement, a rigorous curriculum must be coupled with dynamic execution of instruction. The following strategies and practices are at the core of our academic program:

Strong Emphasis on Differentiated Instruction in Literacy. Our model allows for two groups of 10 scholars to receive direct instruction in phonics and reading comprehension. Scholars will be grouped based on reading levels and literacy proficiency. Teachers will use data to drive instruction and intervention for scholars based on most recent assessment data. This strategic approach allows for increased opportunities for differentiated instruction for all scholars, including our scholars with special needs, ELLs, and those at risk of academic failure. Each scholar will participate in three literacy blocks daily. While one group is receiving direct instruction from one teacher in phonemic awareness, another will receive direct instruction from the other teacher in reading comprehension. Remaining scholars will engage in blended learning, practicing decoding and comprehension skills using a computer-based literacy program. Depending on individual educational development plans, scholars may receive pull-out services for literacy development during time allotted for blended learning.

Word Walls and Anchor Charts will be posted in an organized format by content area, used by scholars in all classrooms. Students will learn the meaning of a resource, and how resources in our world are used to assist us when we do not know certain pieces of information. Across all grades and content areas, resources will be used as an anchor for teacher-to-student prompting, as well as peer-to-peer prompting.

Rap, Rhythm, and Rhyme. Chants, cheers, rhymes, and songs will fill Ivy Hill Prep's hallways. Chanting and rhyming build excitement for learning and play a key role in children remembering concepts across content.

Kinesthetic Learning. Physical activity helps to maintain student engagement, reinforces understanding, and makes learning enjoyable. Scholars will use hand signals to non-verbally communicate with the teacher and one another (i.e. placing one fist on top of another to indicate they are prepared to build off another scholar's response; snapping fingers to show agreement), and reinforce their learning by matching hand signals to key vocabulary.

Taxonomy of Teaching. We will use a variety of academic, behavioral and advanced instructional techniques that reinforce student behavioral and academic expectations, as well as ensuring that teachers constantly build high levels of student engagement. Ivy Hill Prep has adapted many of Doug Lemov's *Teach like a Champion* techniques that allow teachers to maintain structure, teach effectively, check for understanding, and infuse joy simultaneously. Techniques such as Strong Voice, Clear What to Do's, Right is Right, and No Opt Out are present in all classrooms.



Aggressive Monitoring. We will collect data daily from informal and formal assessments. After receiving and analyzing data, teachers will intervene strategically and frequently to close academic gaps as quickly as possible. To ensure teachers are gathering data frequently in the moment, they will be trained to aggressively monitor: a technique used in many high-performing schools across the country. While scholars are independently working, both teachers will have individual zones, or groups of students each is responsible for monitoring. Teachers will evaluate work against an exemplar, using an Aggressive Monitoring Feedback Code to mark each paper and communicate progress to scholars.

Format Matters. Excellence is not an accident, it is purposeful. When scholars respond, orally or in writing, the way they respond is an opportunity to reinforce college readiness skills, such as clarity of language and professionalism. Students will always be encouraged to respond in complete sentences and use correct grammar. The culture will be one of constant growth. Students will become accustomed to being stopped, corrected, and asked to rephrase to practice perfect. By encouraging scholars to *do it again*, they will internalize the corrections and begin to self-correct in the future, when they are writing and when they are speaking.

Ratio. We value a high student talk and think ratio. This means that we prioritize how much teacher talk vs. student talk is present in a classroom. By using different techniques such as choral response, turn and talk, and cold calling, teachers will ensure that scholars' voices are heard. Secondly, we prioritize and value the effectiveness of prompting. When scholars give a partially right or wrong answer, prompting is paramount. Teachers will prompt using universal prompts to push students to the right answer without *giving* them the right answer or just informing them that they are incorrect. As the year progresses and students mature, Ivy Hill Prep teachers will prompt less and less because other scholars will hold their peers accountable by prompting them on a peer-to-peer level. This contributes to the Habits of Discussion and creates a higher student talk *and* think ratio. As scholars mature, not only do we want to hear their voices frequently, we want to ensure students are doing the majority of the cognitive lifting.

Cover Sheet

Vote to Approve 3rd Floor Renovation Plan and Bid

Section: VII. Facilities Update
Item: A. Vote to Approve 3rd Floor Renovation Plan and Bid
Purpose: Vote
Submitted by:
Related Material: IHP 3rd Floor Renovation Bids.pdf



Ivy Hill Preparatory Charter School OFFICIAL RECOMMENDATION

IVY HILL PREPARATORY CHARTER SCHOOL Management Recommendation 12-16-19

Recommendation: North Shore Office Supplies

Background:

We received formal proposals from 4 contractors. All contractors did full walk-throughs of the facility and had individual meetings with the Management Team multiple times.

Recommendation:

Management recommends NSOS (North Shore Office Supplies) is hired to complete all 3rd floor renovations for the following reasons.

- NSOS Satisfies our need for an M/WBE certified organization.
- NSOS comes within our budget allocation for capital improvements.
- We currently have a working relationship with NSOS as an established vendor.
- NSOS reviewed all proposals we were presented with to further understand the scope and develop a proposal that not only meets our needs financially but encompasses the vision of management as we extend into Year 2 and beyond.



Date: 12/12/2019

To: IVY HILL PREP CHARTER SCHOOL 475 E 57th St, Brooklyn, NY 11203	Attention to: Mr. Brandon L. Parker Director of Operations
Subject: PROPOSAL- SCOPE OF WORK FOR: IVY HILL PREP 3RD FLOOR	

Dear Brandon,

Thank you for giving us opportunity to submit the proposal to your Educational dynamic institutes. Attached, please find scope of work proposal for IVY HILL PREP 3rd floor. Scope of work breakdown by Trade.

Total Project Cost: \$107,000.00 (One Hundred Seven Thousand Three Hundred Dollars)

Please note all exclusions as stated below and please contact us with further questions and concerns.

Thank you.

Sincerely,

Meghav Parikh
Director
NSOS INC
Dbas: North Shore Office Supplies
1804 Plaza Avenue Suite 31
New Hyde Park, NY 11040
Tel: (516) 739-1471
Fax: (516)746-1001
Email: nitin@nsofficesupplies.com
Https://www.nsofficesupplies.com

Your Procurement Partner

Certified:

- ✓ **New York State Minority Business Enterprise NYS (MBE) ID # 60909**
- ✓ **NYC Department of Education FAMIS vendor number NSO752699**
- ✓ **NYC – Small Business Services Certification ID number: MWCERT 2016-267**

NSOS
North Shore Office Supplies

<p>GENERAL CONDITIONS \$7,200</p> <ul style="list-style-type: none"> • Personal Protection, Tools, and Equipment • Mobilization, Demobilization, and Tools • Dust Protection and Hallway Cleaning • Container Service throughout project 	<p>\$7,200.00</p>
<p>DEMOLITION \$7,700</p> <ul style="list-style-type: none"> • Remove and Discard Surface-Mounted Blackboards from 2nd Floor Classrooms • Remove and Discard Curtain and Curtain Rods from 2nd Floor Classrooms • Remove and Discard Wall Tile from the following areas: <ul style="list-style-type: none"> ○ Girls and Boys Bathroom 2nd Floor ○ Girls and Boys Bathroom 3rd Floor ○ Stairway from 2nd Floor to 3rd Floor Landing ○ Hallway on 3rd Floor 	<p>\$7,700</p>
<p>GENERAL WORK (CONSTRUCTION) \$54,000</p> <ul style="list-style-type: none"> • Skim coat/patch Walls, Post Wall Tile Removal <ul style="list-style-type: none"> ○ Bathroom, Hallway, and Stairway Walls where Tiles were removed • Walls to receive One (1) Coat of Primer and Two (2) Coats of Paint <ul style="list-style-type: none"> ○ Benjamin Moore Regal or Sherwin Williams Promar 200 ○ Rooms Included: 310, 311, 312, 313A, 313B, 315, 316, Bathrooms 2nd and 3rd Floor, ○ Stairway from 2nd floor to 3rd Floor Landing, 3rd Floor Hallway • Paint Hallways includes the following... <ul style="list-style-type: none"> ○ Doors and Trim – total of Twenty-Three (23) ○ Hallway Walls ○ Corkboard Frames – total of Eighteen (18) • Red Floor Tile around Perimeter of 3rd Floor <ul style="list-style-type: none"> ○ Prepare Floor Tile for Paint to remove existing finish ○ Paint Floor Tile • Patch and Paint areas in 206 & 216 <ul style="list-style-type: none"> ○ 206 – area from removing existing cabinets and shelving ○ 216 – area from removing boards • Furnish and Install Corkboard Material onto Hallway Frames 	<p>\$54,000</p>
<p>CABINETRY - \$1,100</p> <ul style="list-style-type: none"> • Remove existing cabinets and reinstall in 3rd Floor Kitchenette 	<p>\$1,100</p>

NSOS
North Shore Office Supplies

<ul style="list-style-type: none"> • Remove shelving from 216 to 206 • Move shelving from 206 to 3rd Floor Kitchenette • Furnish and Install New Cabinet Doors for Existing Millwork in Existing Computer Room <ul style="list-style-type: none"> ○ Light Shellac on Cabinets and Doors 	
<p>FLOORING - \$25,000</p> <ul style="list-style-type: none"> • Floor Preparation and Patching • Remove and Replace existing VCT Tile w/ Armstrong Standard Excelon VCT <ul style="list-style-type: none"> ○ Rooms included: 310, 311, 312, 313B (according the Client Map), 315 (according to Client Map) • Furnish and Install 4" Rope Rubber Baseboard <ul style="list-style-type: none"> ○ Rooms included: 310, 311, 312, 313A, 313B, 315, 316 	\$25,000
<p>LEARNING BOARDS - \$5,500</p> <ul style="list-style-type: none"> • Install Nine (9), 4'x8' Surface Mounted Whiteboards <ul style="list-style-type: none"> ○ Whiteboards to be provided by Client • Install Nine (9) Surface Mounted Smartboards as shown in Classrooms on 2nd Floor <ul style="list-style-type: none"> ○ Smartboards to be provided by Client 	\$5,500
<p>BATHROOM ACCESSORIES - \$1,500</p> <ul style="list-style-type: none"> • Furnish and Install Two (2) Surface Mounted Soap Dispensers – Bobrick Classic Series • Furnish and Install Two (2) Paper Towel Dispensers – Bobrick Classic Series • Furnish and Install Two (2), 16"x24" Bathroom Mirrors with Stainless Steel Channel Frame • Install new locks on all bathroom stalls • Paint Two (2) Bathroom Partitions 	\$1,500
<p>PLUMBING - \$5,300</p> <ul style="list-style-type: none"> • Remove and Replace Two (2) Water Fountains to Match Existing Fountain on 2nd Floor <ul style="list-style-type: none"> ○ To install on existing roughing 	\$5,300
Total	\$107,000.00

Authorized Signature: 		Authorized Signature:	
Name Print and Title:	Date:	Name Print and Title:	Date:
Meghav Parikh Director NSOS Inc.	12/12/2019	Brandon L. Parker Director of Operations IVY HILL PREP CHARTER SCHOOL	12/12/2019



1804 Plaza Avenue, New Hyde Park, NY
 11040 Tel: 516-739-1471 Fax: 516-746-1001
 Email: admin@nsosofficesupplies.com

RENOVATIONS CONTRACT AGREEMENT

This Renovation Contract Agreement (this “Agreement”) is made as of the 2nd day of January, 2020 by NSOS Inc and between Ivy Hill Prep Charter School, a New York corporation located at 475 East 57th Street, Brooklyn, NY 11203 (“IVY Hill Prep Charter School”) and Nitin Parikh, NSOS Inc. located at 1804 Plaza Avenue, New Hyde Park, NY 11040. IVY Hill Prep Charter School and NSOS Inc may each be referred to in this Agreement individually as a “Party” and collectively as the “Parties.”

The Parties agree as follows:

- 1. Description of Work.** Renovation will be performed at 475 East 57th Street, Brooklyn, NY 11203 (the "Property"), in accordance with agreement made between NSOS Inc & IVY Hill Prep Charter School’s contract plans and specifications. Please see Table A and Table B for specifications and payments.

TABLE A - General Construction specifications and payments:

<p>GENERAL CONDITIONS \$7,200</p> <ul style="list-style-type: none"> • Personal Protection, Tools, and Equipment • Mobilization, Demobilization, and Tools • Dust Protection and Hallway Cleaning • Container Service throughout project 	<p>\$7,200.00</p>
<p>DEMOLITION \$7,700</p> <ul style="list-style-type: none"> • Remove and Discard Surface-Mounted Blackboards from 2nd Floor Classrooms • Remove and Discard Acoustic Panels from 2nd Floor Classrooms • Remove and Discard Curtain and Curtain Rods from 2nd Floor Classrooms • Remove and Discard Wall Tile from the following areas: <ul style="list-style-type: none"> ○ Girls and Boys Bathroom 2nd Floor ○ Girls and Boys Bathroom 3rd Floor ○ Stairway from 2nd Floor to 3rd Floor Landing ○ Hallway on 3rd Floor 	<p>\$7,700</p>
<p>GENERAL WORK (CONSTRUCTION) \$54,000</p> <ul style="list-style-type: none"> • Skimcoat/patch Walls, Post Wall Tile Removal <ul style="list-style-type: none"> ○ Bathroom, Hallway, and Stairway Walls where Tiles were removed • Walls to receive One (1) Coat of Primer and Two (2) Coats of Paint <ul style="list-style-type: none"> ○ Benjamin Moore Regal or Sherwin Williams Promar 200 ○ Ceilings to Painted with a White Flat Finish ○ Rooms Included: 310, 311, 312, 313A, 313B, 315, 316, Bathrooms 2nd and 3rd Floor, ○ Stairway from 2nd floor to 3rd Floor Landing, 3rd Floor Hallway • Paint Hallways includes the following... <ul style="list-style-type: none"> ○ Doors and Trim – total of Twenty-Three (23) ○ Hallway Walls ○ Corkboard Frames – total of Eighteen (18) 	<p>\$54,000</p>

<ul style="list-style-type: none"> • Red Floor Tile around Perimeter of 3rd Floor <ul style="list-style-type: none"> ○ Prepare Floor Tile for Paint to remove existing finish ○ Paint Floor Tile • Patch and Paint areas in 206 & 216 <ul style="list-style-type: none"> ○ 206 – area from removing existing cabinets and shelving ○ 216 – area from removing boards • Furnish and Install Corkboard Material onto Hallway Frames 	
<p>CABINETRY - \$1,100</p> <ul style="list-style-type: none"> • Remove existing cabinets and reinstall in 3rd Floor Kitchenette • Remove shelving from 216 to 206 • Move shelving from 206 to 3rd Floor Kitchenette • Furnish and Install New Cabinet Doors for Existing Millwork in Existing Computer Room <ul style="list-style-type: none"> ○ Light Shellac on Cabinets and Doors 	\$1,100
<p>FLOORING - \$25,000</p> <ul style="list-style-type: none"> • Floor Preparation and Patching • Remove and Replace existing VCT Tile w/ Armstrong Standard Excelon VCT <ul style="list-style-type: none"> ○ Rooms included: 310, 311, 312, 313B (according the Client Map), 315 (according to Client Map) • Furnish and Install 4” Roppe Rubber Baseboard <ul style="list-style-type: none"> ○ Rooms included: 310, 311, 312, 313A, 313B, 315, 316 	\$25,000
<p>LEARNING BOARDS - \$5,500</p> <ul style="list-style-type: none"> • Install Nine (9), 4’x8’ Surface Mounted Whiteboards <ul style="list-style-type: none"> ○ Whiteboards to be provided by Client • Install Nine (9) Surface Mounted Smartboards as shown in Classrooms on 2nd Floor <ul style="list-style-type: none"> ○ Smartboards to be provided by Client 	\$5,500
<p>BATHROOM ACCESSORIES - \$1,500</p> <ul style="list-style-type: none"> • Furnish and Install Two (2) Surface Mounted Soap Dispensers – Bobrick Classic Series • Furnish and Install Two (2) Paper Towel Dispensers – Bobrick Classic Series • Furnish and Install Two (2), 16”x24” Bathroom Mirrors with Stainless Steel Channel Frame • Paint Two (2) Bathroom Partitions 	\$1,500
<p>PLUMBING - \$5,300</p> <ul style="list-style-type: none"> • Remove and Replace Two (2) Water Fountains to Match Existing Fountain on 2nd Floor <ul style="list-style-type: none"> ○ To install on existing roughing 	\$5,300
Table A: Total	\$107,000.00

TABLE B – Student Locker specifications and payments:

<p>OPTION 3: STACK STUDENT LOCKERS We are pleased to provide you with a quote on the following materials:</p> <ul style="list-style-type: none"> • (200) 15”W x 15”D x 24”H • Each 15”W Locker Door includes <hr/> <p>Each locker per student: \$140.00</p> <p>Stacked Lockers: \$28,000.00</p> <p>Removal, Disposal, Installation of Lockers: \$24,000.00</p>	<p>\$52,000</p>
<p>OPTION 3 : Stack Student Lockers <u>Image Reference and Description:</u> (15”W X 15”D X 24”H)</p> 	
<p>Locker Includes: Hat shelf, one double hook and two single hooks. Single tier. One wide. 16 gauge louvered doors and 24 gauge body. Stainless steel recessed handle, three point gravity lift-type latching. Green guard gold certified. Made from cold rolled sheet steel.</p>	
<p>General Exclusions: Concrete including cutting or chopping of slab, masonry, metals, misc. metals, glass and glazing, in-wall blocking, hoisting, storage, installation of owner provided items, lighting fixtures, electrical, plumbing – sinks, piping and connections and HVAC.</p> <p>General Exclusions and Qualifications:</p> <ol style="list-style-type: none"> 1- We must have free use of the elevator(s) and loading dock. Lack of elevator/dock use may result in additional labor for unloading material. 2- Offload and install price based on open access to elevator for all floors. Base bid does not include any equipment and/or elevator engineer if needed. 	

<p>3- Changes in floor plan, sizes, and/or quantities may result in price change.</p> <p>4- All placed orders are subject to a cancellation charge. ^[L]_[SEP]</p> <p>5- Labor rate is based on non-union, non-prevailing open shop wage rate.</p> <p>6- All labor to be performed during weekdays, between 8AM and 4PM with the exception of Saturday for an extended work period.</p> <p>7- Pricing based on one-time delivery and single handling of materials. Partial, storage re-consignment and/or change in delivery date will result in additional charges. Additional charges will be billed by North Shore Office Supplies Inc. and will require <i>payment/approval</i> prior to material being delivered.</p> <p>8- No retainage after 30 days from <i>acceptance/completion</i> of work.</p> <p>9- Project delays of more than (60) days from the material delivery date listed on contract will result in increase labor and material cost.</p> <p>10- All orders placed are subject to a cancellation fee of up to 30 days.</p> <p>11- This quotation must be signed and returned prior to any orders being placed in production.</p> <p>12- This quotation becomes an integral part of North Shore Office Supplies Inc. contract upon signature.</p>	
<p>* 50% Deposit due at contract signing. * Freight charges are subject to vary based on delivery date. * All prices guaranteed firm for 30-day acceptance. * All orders subject to credit approval. * Delivery promises subject to delays due to strikes, fires, and other causes beyond our control.</p>	
<p><u>Sales Tax</u>: Excluded</p> <p><u>Installation</u>: Included</p> <p><u>Delivery</u>: 8-10 weeks after all approvals</p>	
Table B: Total:	\$52,000.00

2. Contract Price and Payments. IVY Hill Prep Charter School agrees to pay NSOS Inc the total amount of \$107,000.00 and \$52,000.00 (the “Contract Price”). Payment of this amount is subject to additions, accordance with any mutually agreed to changes and/or modifications in the Work. Payment will be made by corporate check, according to the following schedule:

Table A: General Construction

- \$53,500.00 deposit, due upon the execution of this Agreement.
- \$26,750.00 due upon flooring is completed.
- \$13,375.00 due prior to initiation of painting.
- \$13,375 balance due upon notice of completion of work.

Table B: Student Lockers

- \$26,000 balance due upon execution of this Agreement.
- \$13,000 balance due upon notice of delivery of student lockers.
- \$13,000 balance due upon notice of completion of work.

Tentative Time Frame of Completion

- On premise construction will begin the week of March 1st 2020.
- Production Time: 8-10 weeks
- Installation and Completion: 3-4 weeks

3. Notification of Completion. Work under this Agreement shall begin on February 10, 2020. Upon completion of the Work, NSOS Inc shall notify IVY Hill Prep Charter School and IVY Hill Prep Charter School shall make the final payment within thirty (30) days.

4. Materials and Labor. NSOS Inc shall provide labor and equipment, including tools, renovation equipment, machinery, transportation and all other facilities and services, and all materials necessary for the completion of the Work. NSOS Inc may substitute materials, tools of equal caliber and will notify need of change.

5. Supervision of Renovation. NSOS Inc will supervise and direct all renovation under this Agreement.

6. Utilities. IVY Hill Prep Charter School shall pay for all permanent electric, water, phone, cable, sewer and gas service as needed to perform the Work.

7. Right to Stop Work. If IVY Hill Prep Charter School fails to make installment payment, NSOS Inc reserves the right to halt work until the payment is made, or an acceptable change in timeline of payment is revised, all attempts will be made to continue work to completion, otherwise in accordance with contract.

8. NSOS Inc's Insurance. NSOS Inc agrees to maintain at its own expense during the entire period of renovation at the Property:

A. General Liability Insurance. Such general liability insurance as will protect NSOS Inc from claims for property damage and bodily injury, with limits of liability.

9. Waiver of Subrogation. IVY Hill Prep Charter School and NSOS Inc each waive any and all claims or rights to recovery against the other Party for any loss or damage to the extent such loss or damage is covered by insurance or would be covered by any insurance required under this Agreement.

10. Extension of Time. The times stated in this Agreement may be extended for such reasonable time as NSOS Inc may determine when performance of the Work by NSOS Inc is delayed by a Change Order, labor disputes, fire,

unusual delay in deliveries, abnormal adverse weather conditions, unavoidable casualties, or other causes beyond NSOS Inc’s control or which justify the delay.

11. Disputes. Any dispute arising from this Agreement shall be resolved through mediation. If the dispute cannot be resolved through mediation, then the dispute will be resolved through binding arbitration conducted in accordance with the rules of the American Arbitration Association.

12. Binding Effect. This Agreement shall be binding and ensure to the benefit of the Parties and their respective legal representatives, heirs, administrators, executors, successors and permitted assigns.

13. Amendments. This Agreement may not be amended or modified except by a written agreement signed by the all of the Parties.

IN WITNESS WHEREOF, the Parties have executed this Agreement as of the date _____.

Mr. Brandon L. Parker	Director of Operations	
IVY Hill Prep Charter School Representative Name	IVY Hill Prep Charter School Representative Title	IVY Hill Prep Charter School Representative Signature

Mr. Nitin C. Parikh	Chief Executive Officer	N.C.Parikh
NSOS Inc Representative Name	NSOS Inc Representative Title	NSOS Inc Representative Signature



Date: 1/17/2020

To: IVY HILL PREP CHARTER SCHOOL 475 E 57th St, Brooklyn, NY 11203	Attention to: Mr. Brandon L. Parker Director of Operations
Subject: PROPOSAL - School Lockers	

Dear Brandon,

We have provided 3 proposal options for the student lockers. Please review and consider all options presented. If there is another way that we can accommodate, please let us know.

Option 1 are the current lockers that you have in place. As you know these lockers are no longer manufactured, so it is now a custom item. We have contacted multiple companies/manufacturers and there are only 2 manufacturers within the U.S. that have the capability to custom make these sizes. This customization significantly drives up the cost of welding and production process. Thus, we do not recommend this option, however we have listed it here for your preference.

Option 2 & 3 are industry standard lockers, and the pricing structure is reflective of the availability. Both these options are very popular with our clients. We recommend you take look at the details of each option and let us know what suits your institution the best.

If Option 1 is a must, we are awaiting a quote from an overseas manufacturer, which may reduce the cost.

Thank you for giving us opportunity to submit the proposal to your Educational dynamic institutes.

Attached, please find the proposals for each option.

Sincerely,

Meghav Parikh
 Director
North Shore Office Supplies
 1804 Plaza Avenue Suite 31
 New Hyde Park, NY 11040
 Tel: (516) 739-1471
 Email: nitin@nsofficesupplies.com
<https://www.nsofficesupplies.com>



OPTION 1: Customized Student locker

We are pleased to provide you with a quote on the following materials:

- (100) 15"W x 12"D x 48"H All-Welded Corridor Lockers
- Each 15"W Locker Door includes (2) 7.5" Doors
- This quote excludes locks, bases, sloped tops, fillers

Student Locker (200): \$169,000.00

Each locker: \$845.00

Image Reference: (15"D X 15" W X 48"H)

These are the customized lockers to match what is in place now.





OPTION 2: Split Student Locker

We are pleased to provide you with a quote on the following materials:

- (100) 15”W x 15”D x 48”H
- Each 15”W Locker Door includes double sided-hooks

Split Lockers: \$17,000.00

Each locker: \$170

Possible to use as a shared locker system.

For Image Reference: Please see green locker



Locker Includes: 3-point gravity latch closure, just like standard school lockers. Hat shelf and coat hooks included (1 double and 2 single hooks). Recessed handle accepts master locks. 16 gauge louvered doors and 24 gauge body. Continuous Piano-hinge on right side of door.



OPTION 3: Stack Student Lockers

We are pleased to provide you with a quote on the following materials:

- (200) 15”W x 15”D x 24”H
- Each 15”W Locker Door includes

Stacked Lockers: \$28,000.00

Each locker per student: \$140.00

Image Reference and Description: (15”W X 15”D X 24”H)



Locker Includes: Hat shelf, one double hook and two single hooks. Single tier. One wide. 16 gauge louvered doors and 24 gauge body. Stainless steel recessed handle, three point gravity lift-type latching. Green guard gold certified. Made from cold rolled sheet steel.



Removal, Disposal, Installation of Lockers: \$24,000.00

General Exclusions: Concrete including cutting or chopping of slab, masonry, metals, misc. metals, glass and glazing, in-wall blocking, hoisting, storage, installation of owner provided items, lighting fixtures, electrical, plumbing – sinks, piping and connections and HVAC

General Exclusions and Qualifications:

- 1- We must have free use of the elevator(s) and loading dock. Lack of elevator/dock use may result in additional labor for unloading material.
- 2- Offload and install price based on open access to elevator for all floors. Base bid does not include any equipment and/or elevator engineer if needed.
- 3- Changes in floor plan, sizes, and/or quantities may result in price change.
- 4- All placed orders are subject to a cancellation charge.
- 5- Labor rate is based on non-union, non-prevailing open shop wage rate.
- 6- All labor to be performed during weekdays, between 8AM and 4PM with the exception of Saturday for an extended work period.
- 7- Pricing based on one-time delivery and single handling of materials. Partial, storage re-consignment and/or change in delivery date will result in additional charges. Additional charges will be billed by North Shore Office Supplies Inc. and will require *payment/approval* prior to material being delivered.
- 8- No retainage after 30 days from *acceptance/completion* of work.
- 9- Project delays of more than (60) days from the material delivery date listed on contract will result in increase labor and material cost.
- 10- All orders placed are subject to a cancellation fee of up to 30 days.
- 11- This quotation must be signed and returned prior to any orders being placed in production.
- 12- This quotation becomes an integral part of North Shore Office Supplies Inc. contract upon signature.

* 50% Deposit due at contract signing.

*All prices guaranteed firm for 30-day acceptance.

*All orders subject to credit approval.

*Delivery promises subject to delays due to strikes, fires, and other causes beyond our control.

Sales Tax: Excluded

Delivery: Included

Installation: Included

Delivery: 6-8 weeks after all approvals



Proposal Agreement

<p>Please Select from the following:</p>	<p>Add Suggestions/Additions/Modifications Below:</p>
<p> <input type="radio"/> OPTION 1: Customized Student Locker <input type="radio"/> OPTION 2: Split Student Locker <input type="radio"/> OPTION 3: Stack Student Locker </p>	
<p>Authorized Signature:</p>	<p>Authorized Signature:</p>
<p> Name Print and Title: Date: Meghav Parikh 1/17/2020 Director NSOS Inc. </p>	<p> Name Print and Title: Date: Brandon L. Parker 1/17/2020 Director of Operations IVY HILL PREP CHARTER SCHOOL </p>

License # 2088507

Licensed, Insured & Bonded

Estimate

Reference 1202777
Date 10th October 2019



To Ivy Hill Prep
475 East 57th Street
Brooklyn, New York
11203

Tel: 646 450 3637
Email: extramileconstr@gmail.com

For 475 East 57th Street
Brooklyn, New York
11203

Dear Ambrosia Johnson,
Thank you for asking us to look at your project for the third floor, here's our estimate for the work. If you've got any questions or we can help with anything else, please just get in touch. We'd be very happy to help.

Painting - classrooms, staircase and bathrooms labour \$12,600

Locker removals \$1,600

Removal of Tiles from walls, Skim-coat walls, removal of tiling from (1) classroom floor \$8,400

Materials \$5,400

Total: \$28,000.00

Yours sincerely

Shameka Johnson



SPROUT.

A PROPOSAL TO: IVY HILL PREP CHARTER SCHOOL

NOVEMBER 21, 2019



WHO WE ARE

BUILD SPROUT

Build Green. Build Smart.

Sprout innovates, stretches your dollars and strives to build using 'green' construction philosophies. Our sustainably focused, yet attractive renovation and construction projects are welcoming places to work, live and learn.

We know that every facet of your project is important. Each detail impacts your day to day experience and we want to be sure you enjoy it.

OUR MISSION

To bring our clients and their stakeholders the best value, by understanding their goals and delivering spaces that are...

- **Innovative**
- **Environmentally Friendly**
- **Economical to Operate**

This is our approach to development, construction, and renovation.

SPROUT, LLC DBA BUILD SPROUT, LLC is a Delaware based limited liability company with authority to conduct business in the State of New York. SPROUT, LLC DBA BUILD SPROUT, LLC is a licensed General Contractor with the City of New York.

LEADERSHIP

ALEX R. JEREZ, FOUNDER

Alex worked for Hines Interests L.P., the largest, privately-held real estate company in the world and a forerunner in bringing sustainability to real estate. The Harvard University graduate has also worked in international real estate finance, and as a property manager for UBS Tower, a Class A office building in Chicago's West Loop. Prior to founding Sprout he served as the former founding director of operations for Children's Aid College Prep Charter School in the Bronx.

CHRISTIAN GUERRERO, PRESIDENT

Christian served as Vice President for two years, prior to his promotion. He provides leadership and oversight on the day-to-day operations for all Construction, Project Management and Project Administration activities associated with the company's commercial and residential projects. Prior to joining Sprout, he served as the co-founder of Inwood Academy for Leadership Charter School in Manhattan.

RICHARD CAMAANO, ADMIN. ASSISTANT

Richard serves as our Administrative Assistant overseeing the logistics between the back-office and field operations. At Sprout he utilizes his skills to ensure and improve the performance, productivity, and efficiency of our construction projects.



IVY HILL PREP CHARTER SCHOOL

Please accept the project bid below as requested by Brandon Parker, Director of Operations. Please note all exclusions as stated below and please contact us with further questions and concerns.

Total Project Cost: \$107,300.00
(One Hundred and Seven Thousand, Three Hundred Dollars)

Scope of Work – Breakdown by Trade

NOTE: Project bid on regular time Monday – Friday 8 am – 5pm.

GENERAL CONDITIONS - \$7,200

- Personal Protection, Tools, and Equipment
- Mobilization, Demobilization, and Tools
- Dust Protection and Hallway Cleaning
- Container Service throughout project

DEMOLITION - \$7,700

- Remove and Discard Surface-Mounted Blackboards from 2nd Floor Classrooms
- Remove and Discard Acoustic Panels from 2nd Floor Classrooms
- Remove and Discard Curtain and Curtain Rods from 2nd Floor Classrooms
- Remove and Discard Wall Tile from the following areas:
 - Girls and Boys Bathroom 2nd Floor
 - Girls and Boys Bathroom 3rd Floor
 - Stairway from 2nd Floor to 3rd Floor Landing
 - Hallway on 3rd Floor

GENERAL WORK (CONSTRUCTION) - \$54,000

- Skimcoat/patch Walls, Post Wall Tile Removal
 - Bathroom, Hallway, and Stairway Walls where Tiles were removed
- Walls to receive One (1) Coat of Primer and Two (2) Coats of Paint
 - Benjamin Moore Regal or Sherwin Williams Promar 200
 - Ceilings to Painted with a White Flat Finish
 - Rooms Included: 310, 311, 312, 313A, 313B, 315, 316, Bathrooms 2nd and 3rd Floor, Stairway from 2nd floor to 3rd Floor Landing, 3rd Floor Hallway
- Paint Hallways includes the following...
 - Doors and Trim – total of Twenty-Three (23)
 - Hallway Walls
 - Corkboard Frames – total of Eighteen (18)
- Red Floor Tile around Perimeter of 3rd Floor
 - Prepare Floor Tile for Paint to remove existing finish
 - Paint Floor Tile



IVY HILL PREP CHARTER SCHOOL

- Patch and Paint areas in 206 & 216
 - 206 – area from removing existing cabinets and shelving
 - 216 – area from removing boards
- Furnish and Install Corkboard Material onto Hallway Frames

CABINERY - \$1,100

- Remove existing cabinets and reinstall in 3rd Floor Kitchenette
- Remove shelving from 216 to 206
- Move shelving from 206 to 3rd Floor Kitchenette
- Furnish and Install New Cabinet Doors for Existing Millwork in Existing Computer Room
 - Light Shellac on Cabinets and Doors

FLOORING - \$25,000

- Floor Preparation and Patching
- Remove and Replace existing VCT Tile w/ Armstrong Standard Excelon VCT
 - Rooms included: 310, 311, 312, 313B (according the Client Map), 315 (according to Client Map)
- Furnish and Install 4" Roppe Rubber Baseboard
 - Rooms included: 310, 311, 312, 313A, 313B, 315, 316

LEARNING BOARDS - \$5,500

- Install Nine (9), 4'x8' Surface Mounted Whiteboards
 - *Whiteboards to be provided by Client*
- Install Nine (9) Surface Mounted Smartboards as shown in Classrooms on 2nd Floor
 - *Smartboards to be provided by Client*

BATHROOM ACCESSORIES - \$1,500

- Furnish and Install Two (2) Surface Mounted Soap Dispensers – Bobrick Classic Series
- Furnish and Install Two (2) Paper Towel Dispensers – Bobrick Classic Series
- Furnish and Install Two (2), 16"x24" Bathroom Mirrors with Stainless Steel Channel Frame
- Paint Two (2) Bathroom Partitions

PLUMBING - \$5,300

- Remove and Replace Two (2) Water Fountains to Match Existing Fountain on 2nd Floor
 - To install on existing roughing

EXCLUDED FROM TOTAL PRICE

ALTERNATE – LOCKERS - \$23,650

- Furnish and Install Thirty-One Units (31), equaling 186 Lockers. It includes the following items...
 - Sloped Top and Kickplate – to prevent unwanted storage and debris on top & bottom of unit
 - Freight, Receipt of Delivery, Assembly and Installation
- Remove and Discard Existing Lockers
- Patch and Paint as Needed





197 S. BROADWAY
YONKERS, NY 10705
www.buildsprout.com

E: admin@buildsprout.com
O: (718) 490-7493
F: (718) 713-1820



Matter Real Estate

Proposal for Renovation of Existing Space

Ivy Hill Preparatory Charter School

MATTER REAL ESTATE

Brandon Parker, Director of Operations
Ivy Hill Preparatory Charter School
475 E. 57th Street
Brooklyn, NY 11203
(917) 789-8959

November 21, 2019

Dear Brandon:

Thank you giving us the opportunity to provide a proposal for the renovation of your school located at 475 E. 57th Street. After completing multiple walkthroughs and carefully reviewing the project's scope of work with AC Interior Group, we are providing you with a quote to complete the project for a **total sum of \$369,570**. Please note that the cost of two person lockers has been included and a credit of \$11,920 will be issued if double tier lockers are chosen. Enclosed, you will find an itemized scope of work, an estimate for the listed work and an alternate estimate for 3rd floor toilet partitions and cut-sheets for equipment.

Matter real estate is a boutique firm providing advisory, project management and owner's representative services to not-for-profits, universities, and commercial developers. Our track record highlights the success I've had helping organizations like Ivy Hill Prep build great spaces that are functional, safe, and economical. We are proud to have worked with clients including Goodwill NY/NJ, Seton Education Partners/Brilla Charter Schools, Academy of the City, and many others.

Please call me to discuss any questions or comments you may have. Thank you again for the opportunity to work with Ivy Hill Prep on this project.

Sincerely,



Principal, Matter Real Estate



MATTER REAL ESTATE

Pending: asbestos report

Floor #2 Renovation Scope

Girls Bathroom

- Replace (2) mirrors
- Piping under the sink to be enclosed (stainless steel)

Boys Bathroom

- Replace (2) mirrors
- Piping under the sink to be enclosed (stainless steel)

Room 206

- Remove existing cabinets and reinstall in 3rd floor kitchen - confirmed
- Room to become a book room (Move shelves from 216)
- Move copy machines from 216 (Install proper electrical outlets)

Room 216

- Replace A/C and move to top window sash
- Move shelving to room 206



MATTER REAL ESTATE

Floor #3 Renovation Scope

Girls Bathroom

- Replace mirrors
- Keep existing flooring
- Keep partitions and paint or replace partitions – alternate estimate provided (Exhibit B)
- Replace sinks
- Piping under the sink to be enclosed (stainless steel)
- Paint walls and ceiling
- Repaint entrance hallway to remove paintings
- Paint ceiling ductwork (Paint to match)

Boys Bathroom

- Replace mirrors
- Change bathroom door hardware
- Keep existing flooring
- Keep partitions and paint or replace partitions – alternate estimate provided (Exhibit B)
- Replace sinks
- Piping under the sink to be enclosed (stainless steel)
- Paint walls and ceiling
- Repaint entrance hallway to remove paintings
- Paint ceiling ductwork (Paint to match)

Room 310 - Side Rooms (Function TBD)

- Remove existing boards & repair walls
- Replace A/C & move to top sash
- Test pipe insulation for asbestos
- Replace flooring
- Paint ceiling / walls / doors / frames / radiators

Room 310

- Install Smartboards
- Replace A/C & move to top sash
- Repair flooring (Do not remove)
- Repaint ceiling / walls / doors / frames / radiators
- (Smart boards are stored in this room)
 - Half repurposed and half are new
 - School will go through hardware to confirm complete installation kits



MATTER REAL ESTATE

Room 311

- Install Smartboards
- Replace A/C & move to top sash
- Replace flooring
- Repaint ceiling / walls / doors / frames / radiators
- (Small space to be treated as a pull-out room)
 - Remove items on walls
 - Repaint ceiling / walls / doors / frames / radiators
 - Replace flooring to match room 311

Room 312

- Install Smartboards
- Replace A/C & move to top sash
- Replace flooring
- Repaint ceiling / walls / doors / frames / radiators

Room 313A

- Install Smartboards
- Replace A/C & move to top sash
- Replace flooring
- Repaint ceiling / walls / doors / frames / radiators

Room 313B

- Install Smartboards
- Replace A/C & move to top sash
- Replace flooring
- Repaint ceiling / walls / doors / frames / radiators

Room 313 - DOO (Function TBD)

- Remove A/C (Keep electrical for future A/C)
- Remove carpet & replace flooring
- Repaint ceiling / walls / doors / frames / radiators

Room 313 - Kitchen

- Remove old cabinets
- Move 2nd floor kitchen cabinets to 3rd floor
- Remove shelving & items from walls
- Repaint ceiling / walls / doors / frames / radiators
- Install new outlets for kitchen appliances
- **Asbestos tile testing?**



MATTER REAL ESTATE

Room 314

- Install Smartboards
- Replace A/C & move to top sash
- Replace flooring
- Repaint ceiling / walls / doors / frames / radiators

Room 315

- Install Smartboards
- Replace A/C & move to top sash (Remove 1 A/C)
- Repaint ceiling / walls / doors / frames
- Repaint lab table legs
- Repair and repaint cabinet doors

Room 316

- Install Smartboards
- Replace A/C & move to top sash
- Replace flooring
- Repaint ceiling / walls / doors / frames / radiator
- Asbestos tile testing?

Room 318

- Install Smartboards
- Replace A/C & move to top sash (Remove extra A/C)
- Repaint ceiling / walls / doors / frames/ radiators
- Asbestos tile testing?

Stairway A

- Remove existing chair rail tile
- Paint front of steps
- Paint cast iron railings
- Paint stairwells

Hallways

- Remove existing chair rail wall tiles
- Replace existing lockers with new equivalent two person lockers
- Repaint hallway, doors, door frames, elevator door, lockers
 - Paint over red trim floor tiles
- Replace corkboard base & paint frames
- Replace 3 exit signs
- Install 2 new water fountains w/ bottle filler



MATTER REAL ESTATE

We appreciate the opportunity to submit this proposal and look forward to working with you on this exciting project. If the terms and conditions set forth above are acceptable, please sign, date and return a copy of the proposal.

ACCEPTED AND AGREED:

By: _____ Date: _____

Authorized Signatory
Ivy Hill Preparatory Charter School



MATTER REAL ESTATE

Exhibits



MATTER REAL ESTATE

Exhibit A: Project Estimate



AC Interior Group
 30 Wall Street, 8th Floor
 New York, NY 10005 US
 (212) 796-4390
 info@acinteriorgroup.com
 http://www.acinteriorgroup.com



Estimate 20192459

ADDRESS

Ivy Hill Prep
 475 East 57th Street
 Brooklyn, NY 11203

DATE	TOTAL
11/12/2019	\$329,570.00

ACTIVITY	QTY	RATE	AMOUNT
Bathroom Renovation 2nd Floor Boys Bathroom • Replace (2) mirrors \$650.00 • Piping under the sink to be enclosed \$1500.00 stainless steel	1	2,150.00	2,150.00
Bathroom Renovation 2nd Floor Girls Bathroom • Replace (2) mirrors \$650.00 • Piping under the sink to be enclosed \$2500.00 stainless steel	1	3,150.00	3,150.00
Bathroom Renovation 3rd Floor Girls Bathroom • Replace (2) mirrors \$650.00 • Keep existing flooring • Remove existing sinks • Supply and install 2 wall mount sink & metering faucets \$4800.00 • Piping under the sink to be enclosed \$2500.00 stainless steel • Paint walls and ceiling \$2000.00 • Repaint entrance hallway to remove paintings • Paint ceiling ductwork (Paint to match)	1	9,950.00	9,950.00
Bathroom Renovation 3rd Floor Boys Bathroom • Replace (2) mirrors \$650.00 • Keep existing flooring • Remove existing sink • Supply and install 1 wall mount sink & metering faucet \$2400.00 • Piping under the sink to be enclosed \$1500.00 stainless steel • Paint walls and ceiling \$2000.00 • Repaint entrance hallway to remove paintings • Paint ceiling ductwork (Paint to match)	1	6,550.00	6,550.00
General Construction 3rd floor Hallway • Remove existing chair rail wall tiles (around door frames x13) \$19,500.00 • Repaint hallway walls, doors, door frames, elevator door, \$7500.00 • Replace corkboard base & paint frames (12) \$9600.00 • Replace 3 exit signs (included in electric scope) • Install 2 new water fountains w/ bottle filler \$3500 x 2 = \$7000.00	1	43,600.00	43,600.00
General Construction Room 206 • Remove existing cabinets and reinstall in 3rd floor kitchen \$500.00 • Room to become a book room (Move shelves from 216) \$500.00 • Move copy machines from 216 (included in electric scope)	1	1,000.00	1,000.00
General Construction Room 216 • Replace A/C and move to top window sash \$4000.00 w/ new ritter kit • Move shelving to room 206 \$500.00	1	4,500.00	4,500.00
General Construction Room 310 - Side Rooms (Function TBD) • Remove existing boards & repair walls \$750.00 • Replace A/C & move to top sash \$4000.00 w/ new ritter kit • Replace flooring (included in flooring cost below) • Paint ceiling / walls / doors / frames / radiators \$2000.00	1	6,750.00	6,750.00

ACTIVITY	QTY	RATE	AMOUNT
General Construction Room 310 • Install Smartboards \$1500.00 (Install, new cables, raceways & connectors with HDMI box / cable management & focus/setup) • Replace A/C & move to top sash \$4000.00 w/ new ritter kit • Repair flooring (Do not remove) • Repaint ceiling / walls / doors / frames / radiators \$5000.00 (Smart boards are stored in this room) o Half repurposed and half are new o School will go through hardware to confirm complete installation kits	1	10,500.00	10,500.00
General Construction Room 311 • Install Smartboards \$1500.00 (Install, new cables, raceways & connectors with HDMI box / cable management & focus/setup) • Replace A/C & move to top sash \$4000.00 w/ new ritter kit • Replace flooring • Repaint ceiling / walls / doors / frames / radiators \$4000.00 (Small space to be treated as a pull-out room)	1	9,500.00	9,500.00
General Construction Room 312 • Install Smartboards \$1500.00 (Install, new cables, raceways & connectors with HDMI box / cable management & focus/setup) • Replace A/C & move to top sash \$4000.00 w/ new ritter kit • Replace flooring • Repaint ceiling / walls / doors / frames / radiators \$4000.00	1	9,500.00	9,500.00
General Construction Room 313A • Install Smartboards \$1500.00 (Install, new cables, raceways & connectors with HDMI box / cable management & focus/setup) • New whiteboards / corkboards 2 - 4 x 8 corkboards \$1000.00 & 2 - 4 x 8 whiteboards \$2400.00) • Replace A/C & move to top sash \$4000.00 w/ new ritter kit • Replace flooring • Repaint ceiling / walls / doors / frames / radiators \$2500.00	1	11,400.00	11,400.00
General Construction Room 313B • Install Smartboards \$1500.00 (Install, new cables, raceways & connectors with HDMI box / cable management & focus/setup) • Replace A/C & move to top sash \$4000.00 w/ new ritter kit • Replace flooring • Repaint ceiling / walls / doors / frames / radiators \$3500.00	1	9,000.00	9,000.00
General Construction Room 313 - DOO (Function TBD) • Remove A/C (Keep electrical for future A/C) \$250.00 for removal/dispose • Remove carpet & replace flooring • Repaint ceiling / walls / doors / frames / radiators \$2000.00	1	2,250.00	2,250.00
General Construction Room 313 - Kitchen • Remove old cabinets \$500.00 • Move 2nd floor kitchen cabinets to 3rd floor \$1500.00 • Remove shelving & items from walls \$250.00 • Repaint ceiling / walls / doors / frames / radiators \$2000.00	1	4,250.00	4,250.00
General Construction Room 314 • Install Smartboards \$1500.00 (Install, new cables, raceways & connectors with HDMI box / cable management & focus/setup) • Replace A/C & move to top sash \$4000.00 w/ new ritter kit • Replace flooring • Repaint ceiling / walls / doors / frames / radiators \$3500.00	1	9,000.00	9,000.00
General Construction Room 315 • Install Smartboards \$1500.00 (Install, new cables, raceways & connectors with HDMI box / cable management & focus/setup) • Replace A/C & move to top sash (Remove 1 A/C) \$4000.00 w/ new ritter kit • Repaint ceiling / walls / doors / frames \$3500.00 • Repaint lab table legs \$250.00 • Replace and paint 7 cabinet doors 2800.00	1	12,050.00	12,050.00
General Construction Room 316 • Install Smartboards \$1500.00 (Install, new cables, raceways & connectors with HDMI box / cable management & focus/setup) • Replace A/C & move to top sash \$4000.00 w/ new ritter kit • Replace flooring • Repaint ceiling / walls / doors / frames / radiator \$3500.00	1	9,000.00	9,000.00
General Construction Room 318 • Install Smartboards \$1500.00 (Install, new cables, raceways & connectors with HDMI box / cable management & focus/setup) • Replace A/C & move to top sash (Remove extra A/C) \$4000.00 w/ new ritter kit • Repaint ceiling / walls / doors / frames/ radiators \$3500.00	1	9,000.00	9,000.00

ACTIVITY	QTY	RATE	AMOUNT
Painting Stairway A • Remove existing chair rail tile • Paint front of steps • Paint cast iron railings • Paint stairwells	1	10,500.00	10,500.00
Electric Rooms 216, 310,311, 312, 313A, 313B, 314, 315, 316, 318 Relocate existing AC receptacle and install switch outlet 3rd Floor Water coolers- correct defective wiring for new water coolers. Install GFI receptacle for new water cooler. 3rd Floor Supply and install 3 Exit signs with battery back -up at existing locations Kitchen Supply and install 1 /115volt 20amp circuit for refrigerator 1 /115volt 20amp circuit for Microwave 1 /115volt 20amp circuit for Duplex receptacle on counter	1	24,600.00	24,600.00
Flooring Room 310 ,311,312,313,313A,313B,314,315,316,318 Smooth coat floors. Supply and install VCT tiles Supply and install cove base	1	59,600.00	59,600.00
Paint Epoxy paint floor tiles in 1 hallway. Prepare and paint all red floor tiles around hallway perimeter.	1	3,200.00	3,200.00
AV Tech Support \$200.00 per hour, 1 hour minium. Technician to sort and inventory all projectors and parts. Create list of missing parts to complete installations, if needed. Any time not used will be credited back. Budget 4 hours.	4	200.00	800.00
Lockers Supply and new 2 person locker (226 lockers/doors)	1	57,770.00	57,770.00
Lockers credit If double tier lockers are chosen, deduct \$11,920.00	0	11,920.00	0.00

TOTAL **\$329,570.00**

THANK YOU.

Accepted By

Accepted Date

MATTER REAL ESTATE

Exhibit B: Toilet Partition Estimate



AC Interior Group
 30 Wall Street, 8th Floor
 New York, NY 10005 US
 (212) 796-4390
 info@acinteriorgroup.com
 http://www.acinteriorgroup.com



Estimate 20192451

ADDRESS	DATE	TOTAL
Ivy Hill Prep 475 East 57th Street Brooklyn, NY 11203	11/11/2019	\$0.00

ACTIVITY	QTY	RATE	AMOUNT
Bathroom Renovation • 3rd floor girls bathroom Keep partitions and paint (fix hardware) \$2400.00 paint, \$500.00 repairs	0	2,900.00	0.00
Bathroom Renovation • 3rd floor boys bathroom Keep partitions and paint (fix hardware) \$1600.00 paint, \$500.00 repairs	0	2,100.00	0.00
Partitions 3rd floor Bathroom Partitions Remove existing partitions Supply and install (3) Toilet Compartments Supply and install (3) new toilet paper dispensers, by Bobrick. Type: Solid Plastic-Standard, Floor Mounted Overhead Braced Features: Standard height, Stirrup brackets, Standard color Elevator usage is mandatory for distribution of material. If elevator is unavailable, Additional costs will be incurred. These added costs will be determined based on job Site conditions.	0	9,550.00	0.00

TOTAL \$0.00

THANK YOU.

Accepted By

Accepted Date

MATTER REAL ESTATE

Exhibit C: Equipment Cut Sheets





COLOR SELECTION FORM

Please select a color below. Note: for multi-colored orders, please annotate the color / texture on submittal drawings.

Standard lead times apply

Standard Color Choices

Classic Color Collection

Orange Peel Texture	
Black	
Blueberry	
Burgundy	
Charcoal Grey	
Desert Beige	
Fossil	
Grey	
Hunter Green	
Linen	
Mocha	
White	
French Blue	

EX Texture	
Black	
Desert Beige*	

Metallic Color Collection

Hammered Texture	
Stainless	
Bronze	
Nickel	
Rotary Brushed Texture	
Stainless	
Bronze	
Nickel	
EX Texture	
Stainless	

Mosaic Color Collection

Orange Peel Texture	
Bluestone*	
Glacier Grey	
Gravel*	
Onyx*	
Paisley	
Sandcastle	
Sandstone	
Storm*	

Designer Color Collection

Orange Peel Texture	
Mahogany	
Shale	
Concrete	

Fire Rated Color Choices

Fire Rated Materials

Class B

Orange Peel Texture	
Black	
Blueberry	
Paisley	
Desert Beige	
Linen	
Mocha	
Grey	
Charcoal Grey	
White	

Hammered Texture

Stainless	
Bronze	
Nickel	

Fire Rated Materials

Class A, NFPA 286

Orange Peel Texture	
Black	
Blueberry	
Paisley	
Desert Beige	
Linen	
Mocha	
White	

Hardware Options

Continuous Plastic

Brackets / Shoes

Black	
Blueberry	
Desert Beige	
Grey	
Linen	
Mocha	

Bracket Types

Plastic (specify color above)
Stainless Steel Stirrup
Aluminum Stirrup
**Continuous Stainless Steel
**Continuous Aluminum

**Upcharges Apply

Shoes

Plastic (specify color above)
Stainless Steel



AMERICAN SPECIALTIES, INC.
 441 Saw Mill River Road, NY 10701
 (914) 476.9000 • (914) 476.0688
 www.americanspecialties.com

MODEL №: 0535
ISSUED: 01/87
REVISED: 19 FEB 2018

FIXED ANGLE TILTED MIRROR

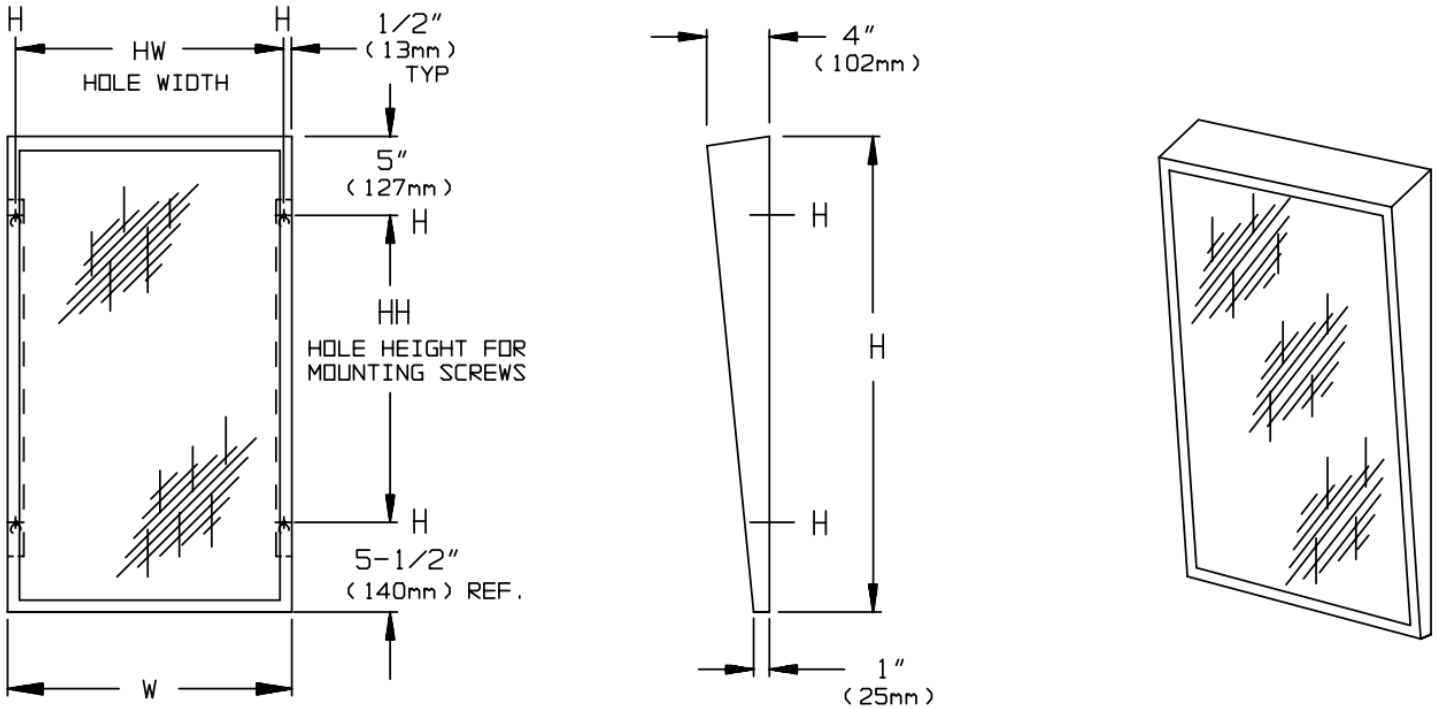

SPECIFICATION

Fixed Angle Tilted Mirror shall be fabricated of alloy 18-8 stainless steel, type 304, 20 gauge. Face shall be one piece construction free of miters or spot welded seams. All exposed surfaces shall have No 4 satin finish and be protected during shipment by plastic PVC film easily removable after installation. Concealed tamper resistant locking devices shall be provided. Mirror shall be _____ (INSERT GLAZING OPTION) and shall be warranted for 15 years against silver spoilage. Mirrors shall be supplied as standard with glazing option ' A '. For a complete description and other choices of glazing options, see the Mirror Glazing OPTIONS Chart.

Fixed Angle Tilted Mirror shall be Model No 0535-_____ (insert glazing option) - _____ (insert size code) manufactured by American Specialties, Inc., Yonkers, NY 10701-4913.

INSTALLATION

Unit is surface mounted on wall or partition using four (4) No 10 self tapping screws (by others). Mounting holes through back are "keyhole" slots for hanging unit on pre-installed screws. Unit requires $5/8"$ (16mm) clearance at top to engage screws in keyhole slots. For compliance with 2010 ADA Accessibility Standards, bottom of reflecting surface should be installed $40"$ (1016mm) max. above finished floor.

AVAILABLE MODELS

MODEL №	DIMENSIONS			
	W	H	HW	HH
0535-____-1630	16" (406mm)	30"(762mm)	15"(381mm)	19-1/2"(495mm)
0535-____-1824	18" (457mm)	24"(610mm)	17" (432mm)	13-1/2"(343mm)
0535-____-1830	18" (457mm)	30"(762mm)	17" (432mm)	19-1/2"(495mm)
0535-____-1836	18" (457mm)	36"(914mm)	17" (432mm)	25-1/2"(648mm)
0535-____-2430	24" (610mm)	30"(762mm)	23" (584mm)	19-1/2"(495mm)
0535-____-2436	24" (610mm)	36"(914mm)	23" (584mm)	25-1/2"(648mm)



AMERICAN SPECIALTIES, INC.
 441 Saw Mill River Road, Yonkers, NY 10701
 (914) 476.9000 • (914) 476.0688
 www.americanspecialties.com

MODEL №:	GLAZINGS
ISSUED:	1-87
REVISED:	22 MAY 2014

MIRROR GLAZING OPTIONS

GLAZING SUFFIX	DESCRIPTION
A	Plate Glass - 1/4" (6.4mm) thick № 1 quality polished, silver coated and hermetically sealed with a uniform coating of electrolytic copper plating. Mirrors meet Federal Spec. № DD-M-411C, ASTM C-1503 and ASTM-C-1036-91. Image quality: Excellent
B (1,2,3)	Tempered Glass - 1/4" (6.4mm) thick polished tempered glass with two coats of silver applied. Electroplating with a heavy uniform coating of copper hermetically seals the silver. Back of mirror is finished and protected with a thick coat of heavy waterproof paint. Glazing meets Federal Specification № DD-G1403B, Amendment 1, ASTM C-1503 and ASTM-C-1048-92. Image quality: Good
C (1,2,3)	Metal Mirrors - Shall be Type 304 alloy 18-8 stainless steel, 20 gauge polished to a № 8 mirror finish. Image quality: Good
D (1)	Lexan Dura-Mirror - 1/4" (6.4mm) thick polycarbonate sheet, highly impact resistant. Mirror face is provided with a thick removable masking to prevent scratching during installation. Image quality: Very Good
E (1)	Plexiglas® - Shall be 1/4" (6.4mm) thick acrylic plastic, lightweight and highly shock resistant. Image quality: Very Good
L (1)	Mirror is fabricated with an interlayer of 1/32" (.8mm) thick vinyl bonded between two 1/8" (3mm) thick sheets of № 1 quality polished plate glass with back silver coated and hermetically sealed with a uniform coating of electrolytic copper plating. Back of mirror is finished and protected with a thick coat of heavy-duty waterproof paint. Laminated glass meets the performance criteria of Federal Spec. № DD-M-451 and ANSI Z87.1 specifications and complies with CPSC standards 16 CR 1201 (1) 11. Image quality: Excellent

NOTES

1. Glazing types indicated are particularly suited to applications where frequent breakage and/or security problems exist. These surfaces are best specified for use in prisons, schools, police stations, hospital wards, etc., where shards of broken glass might possibly be used as weapons.
2. The reflective quality of these mirror types is not as true as plate glass.
3. ASI will not accept returns of these mirror types based upon claims of distortion in reflective properties.



service dependability
 excellence quality
 integrity

Specifications

Standard Lockers the industry benchmark

Single, Double, Triple & Four Tier, Box, Two Person, Duplex and Double Door



Lock Combination Listings and Master Keys: Use only when combination locks are specified. Delivered directly to the owner's representative.

1.3 QUALITY ASSURANCE:

1.3.1 UNIFORMITY: Provide each type of metal locker as produced by a single manufacturer, including necessary accessories, fittings and fasteners.

1.3.2 JOB CONDITIONS: Do not deliver metal lockers until building is enclosed and ready for locker installation. Protect from damage during delivery, handling, storage and installation.

PART 2- PRODUCTS

2.1 MANUFACTURER:

Republic Storage Systems, LLC. Products by other manufacturers may be approved provided they meet the detailed specifications written below. Approval procedure shall be as specified in the General Conditions of these locker specifications.

PART 1- GENERAL

1.1 RELATED DOCUMENTS:

We suggest use of your standard office reference to drawing, general and special conditions, etc.

1.2 SCOPE:

Furnish and install new steel lockers, accessories and finish metal trim as shown or indicated on approved drawings. Concrete or masonry bases, wood furring, blocking or trim as may be required by drawings are included in other sections of this specification.

1.2.1 SUBMITTALS:

Shop Drawings: Submit drawings showing locker types, sizes and quantities, including all necessary details relating to anchoring, trim installation and relationship to adjacent surfaces.

Numbering: The locker numbering sequence shall be provided by the approving authority and noted on the approved drawings returned to the locker contractor.

Color Charts: Provide color charts showing manufacturer's available colors. If required by normal office procedures or in the event of non-standard color selection, request samples of paint on metal.

2.2 LOCKERS:

Configuration:

- Single Tier
- Double Tier
- Triple Tier
- Four Tier
- Two Person
- Duplex
- Double Door
- Box

Size: _____

Color: _____

No. of Locker Frames: _____

No. of Locker Openings: _____

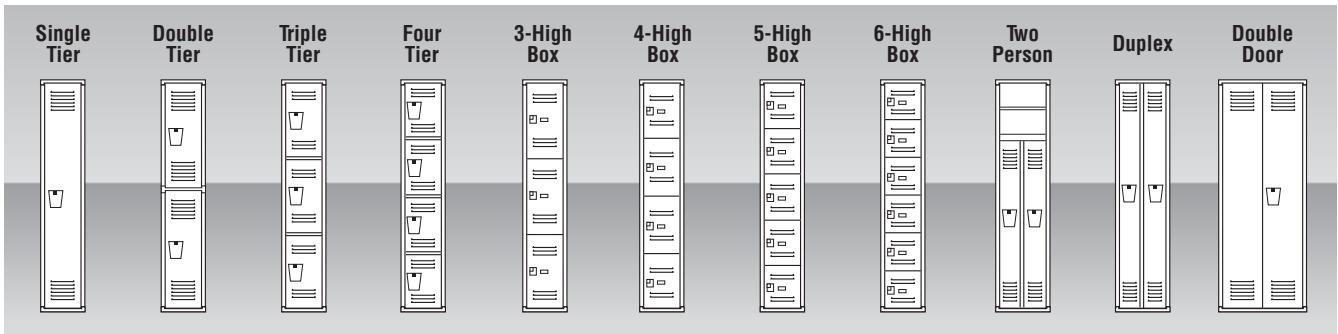

Standard Lockers the industry benchmark

Single, Double, Triple & Four Tier, Box, Two Person, Duplex and Double Door

2.3 FABRICATION - GENERAL:

2.3.1 MATERIAL: All major steel parts shall be made of mild cold rolled steel, free from imperfections and capable of taking a high grade baked enamel or powder coat finish.

-ALTERNATE: Specified locker components shall be manufactured from Galvannealed steel and finished by manufacturer's standard process.

2.3.2 FINISH: Surfaces of the steel shall be thoroughly cleaned, phosphatized and prepared for baked enamel or powder coat finish in accordance with paint manufacturer's instructions.

2.3.3 CONSTRUCTION: Lockers shall be built on the unit principle - each locker shall have an individual door and frame, an individual top, bottom, back and shelves with common intermediate uprights separating units.

2.3.4 DOOR FRAMES: Door frames shall be 16 gauge formed into 1" wide face channel shapes with a continuous vertical door strike, integral with the frame on both sides of the door opening. Double, triple or four tier locker cross frame members shall be 16 gauge channel shaped securely welded to vertical framing members to ensure a square and rigid assembly. Intermediate cross frame members are not required on box lockers.

2.3.5 DOORS: Shall be 16 gauge or 18 gauge steel for short or narrow doors as required by manufacturer's design, formed with a full channel shape on the lock side to fully conceal the lock bar, channel formation on the hinge side and right angle formation across the top and bottom. Single tier doors 60" and 72" in height and 18" and wider shall have a diagonal reinforcing angle welded to inner surface. Doors for Standard Box Lockers 3, 4, 5 and 6 openings high are 16 or 18 gauge steel and shall be formed with right angle flanges on all four sides. Locker doors shall be ventilated by louvers on the face of each door, top and bottom.

2.3.6 PRE-LOCKING DEVICE: All "tiered" lockers shall be equipped with a positive automatic pre-locking device, whereby the locker may be locked while door is open and then closed without unlocking and without damaging locking mechanism.

2.3.7 LATCHING: Latching shall be a one-piece, pre-lubricated spring steel latch, completely contained within the lock bar under tension to provide rattle-free operation. The lock bar shall be of pre-coated, double-channel steel construction. The lock bar shall be securely contained in the door channel by self-lubricating polyethylene guides that isolate the lock bar from metal-to-metal contact with the door. There shall be three latching points for

lockers over 42" in height and two latching points for all tiered lockers 42" and under in height. The lock bar travel is limited by contacting resilient high-quality elastomeric cushioning devices concealed inside the lock bar. Frame hooks to accept latching shall be of heavy gauge steel, set close in and welded to the door frame. Continuous vertical door strike shall protect frame hooks from door slam shall protect frame hooks from door slam damage. A soft rubber silencer shall be securely installed on each frame hook to absorb the impact caused by closing of the door. Box locker doors shall be equipped with a padlock hasp and a stainless steel strike plate with an integral handle pull. Box locker doors may also be equipped with built-in locks.

2.3.8 HANDLES: A non-protruding 14 gauge lifting trigger and slide plate shall transfer the lifting force for actuating the lock bar when opening the door. The exposed portion of the lifting trigger shall be encased in a molded ABS thermoplastic cover that provides isolation from metal-to-metal contact and be contained in a formed 20 gauge stainless steel recessed pocket. This stainless steel pocket shall contain a recessed area for the various lock types available and a mounting area for the number plate.

2.3.9 HINGES: Hinges shall be 2" high, 5-knuckle, full loop, tight pin style, securely welded to frame and double riveted to the inside of the door flange. Locker doors 42" high and less shall have two hinges. Doors over 42" high shall have three hinges.

2.3.10 BODY: The body of the locker consists of 24 gauge upright sheets, backs, tops, bottoms and shelves. Tops, bottoms and shelves are flanged on all four sides; backs are flanged on two sides. Uprights shall be offset at the front and flanged at the rear to provide a double lapped rear corner. All bolts and nuts shall be zinc plated.

2.3.11 INTERIOR EQUIPMENT: Single tier lockers over 42" high shall have one hat/book shelf. Other tiered lockers do not require shelves. All single, double and triple tier lockers shall have one double prong rear hook (single prong in 9" width) and two single prong side hooks in each compartment. All hooks shall be made of steel, formed with ball points, zinc-plated and attached with two bolts or rivets. Locker openings under 20" high are not equipped with hooks.

2.3.12 NUMBER PLATES: Each locker shall have a polished aluminum number plate with black numerals not less than 1/2" high. Plates shall be attached with rivets to the lower surface within the recessed handle pocket.

2.3.13 COLOR: Doors and exposed body parts shall be finished in colors selected from Republic's collection of twenty-five baked enamel colors. Non-exposed body parts shall be finished in #83 Decorator Tan (baked enamel).

-ALTERNATE: Doors and exposed body parts shall be finished in colors selected from Republic's collection of nine powder coat colors. Non-exposed body parts shall be finished in #83 Decorator Tan (baked enamel).

-ALTERNATE: Entire locker shall be finished in colors selected from Republic's collection of nine powder coat colors.

-OPTION: Specifier may modify above paragraph if non-standard custom colors are selected.

2.3.14 ASSEMBLY: Assembly of all locker components shall be accomplished by the use of zinc plated, low round head, slotless, fin neck machine screws with hex nuts, producing a strong mechanical connection.

-OPTION: Keps nuts and bolts or rivets and washers may be used for assembly.

PART 3 - EXECUTION

3.1 INSTALLATION:

Lockers must be installed in accordance with manufacturer's approved drawings and assembly instructions. Installation shall be level and plumb with flush surfaces and rigid attachment to anchoring surfaces. Space fasteners at 36" O.C. or less, as recommended by manufacturer. Use fasteners appropriate to load and anchoring substratum. Use reinforcing plates wherever fasteners could distort metal. Various trim accessories where shown, such as sloping tops, fillers, bases, recessed trim, etc., shall be installed using concealed fasteners. Flush, hairline joints are provided at all abutting trim parts and at adjoining surfaces.

3.2 ADJUSTMENT:

Upon completion of installation, inspect lockers and adjust as necessary for proper door and locking mechanism operation.

3.3 QUALITY ASSURANCE:

Republic reserves the right to modify the design and/or change specifications or colors/finish consistent with our policy of product excellence.

NOTE: For user safety, all Republic lockers must be secured to the wall and/or floor prior to use.

ELKAY® SPECIFICATIONS

EZH2O® Bottle Filling Station with Single EZ Cooler Models EZS8WS & EZSDWS

RATED FOR INDOOR USE ONLY

PRODUCT SPECIFICATION

Unit shall include electric water cooler with bottle filling station. EZS8WS shall deliver 8 GPH of 50°F drinking water at 90°F ambient and 80°F inlet water. EZSDWS shall deliver non-chilled drinking water. Units shall have pushbar activation. Bottle filling unit shall include an electronic sensor for touchless activation with auto 20-second shut-off timer. Shall include Green Ticker™ displaying count of plastic bottles saved from waste. Bottle filler shall provide 1.1-1.5 gpm flow rate with laminar flow to minimize splashing. Shall include integrated silver ion anti-microbial protection in key areas. Unit shall meet ADA guidelines. Unit shall be lead-free design which is certified to NSF/ANSI 61 and 372 and meets Federal and State low-lead requirements. Unit shall be certified to UL399 and CAN/CSA 22.2 No. 120.

STANDARD FEATURES

- Sanitary, touchless activation with auto 20-second shut-off (Bottle Filler)
- Easy-touch front and side pushbar controls (Cooler)
- Integrated Silver Ion Anti-microbial Protection in key areas
- Quick Fill Rate: 1.1 gpm (EZS8WS); 1.5 gpm (EZSDWS)
- Laminar Flow provides minimal splash
- Real Drain System eliminates standing water
- Visual User Interface display includes:
 - Innovative Green Ticker™ counts bottles saved from waste
- Available with Flexi-Guard® StreamSaver™ or Vandal-Resistant® bubbler (includes "VR" code in model no.)
- Cooler panel finishes: Light Gray Granite Vinyl Clad Steel or Stainless Steel

COOLING SYSTEM (Models EZS8WS & EZS8WSVR only)

- Compressor: hermetically-sealed, reciprocating type, single phase. Sealed-in lifetime lubrication.
- Condenser: Fan cooled, copper tube with aluminum fins. Fan motor is permanently lubricated.
- Cooling Unit: Combination tube-tank type. Self-cleansing. Continuous copper tubing with stainless steel tank. Fully insulated with EPS foam which meets UL requirements for self-extinguishing material.
- Refrigerant Control: Refrigerant R134a is controlled by accurately calibrated capillary tube.
- Temperature Control: Easily accessible enclosed adjustable thermostat is factory preset. Requires no adjustment other than for altitude requirements.

CAPACITIES CHART

Model	Voltage / Hertz	Chilling** Capacity	F.L. Amps	Rated Watts	Approx. Ship Wt.
EZS8WS(VR)*K	115V / 60Hz	8 GPH	5.0	370	88
EZS8WS(VR)*2K	220V / 50Hz	6.7 GPH	2.5	370	
EZS8WS(VR)*3K	220V / 60Hz	8 GPH	2.5	370	
EZSDWS(VR)*K	115V / 60Hz	-	1.0	15	58
EZSDWS(VR)*2K	220V / 50Hz	-	0.5	15	
EZSDWS(VR)*3K	220V / 60Hz	-	0.5	15	

*Color code of (L) Light Gray Granite or (S) Stainless Steel cooler panels.

**Based on 80°F inlet water & 90°F ambient air temp for 50°F chilled drinking water.



Models EZS8WSSK or EZSDWSSK



Models EZS8WSVRLK or EZSDWSVRLK

CONSTRUCTION

- Stainless Steel basin with integral drain
- Galvanized structural steel cooler chassis provides structural integrity
- Stainless steel bottle filler wrapper with ABS plastic Alcove
- Cooler cabinet available as Light Gray Granite Vinyl Clad Steel or Stainless Steel (additional cost) construction
- Flexi-Guard® StreamSaver™ Safety Bubbler (option) utilizes an infused anti-microbial pliable polyester elastomer to prevent accidental mouth injuries. Flexes on impact. Lower-flow water efficient water stream.
- Vandal-resistant bubbler (option) is one-piece heavy-duty chrome-plated

Warranty: 5 year limited warranty on the unit's refrigeration system. Electrical components and water system are warranted for 12 months from date of installation or 18 months from factory shipment, whichever date falls first.

CERTIFICATIONS / STANDARDS

- ADA Compliant
- UL399 and CAN/CSA 22.2 No. 120 Certified (Only 115V models are certified)
- ANSI/NSF 61 and 372 Certified
- GreenSpec® Listed



This specification describes an Elkay product with design, quality and functional benefits to the user. When making a comparison of other producer's offerings, be certain these features are not overlooked.

In keeping with our policy of continuing product improvement, Elkay reserves the right to change specification without notice. Please visit elkaypro.com for the most current version.

2222 Camden Court
OakBrook, IL 60523
630-572-3192
elkaypro.com

© 2014 Elkay
SPEC14-60 (03/2014)

EZH20® Bottle Filling Station with Single EZ Cooler Models EZS8WS & EZSDWS



RATED FOR INDOOR USE ONLY

IMPORTANT! INSTALLER PLEASE NOTE:

These units are designed and built to provide water to the user which has not been altered by materials in the cooler waterway. The grounding of electrical equipment such as telephone, computers, etc. to water lines is a common procedure. This grounding may be in the building but may also occur away from the building. This grounding can cause electrical feedback into a water cooler creating an electrolysis which results in a metallic taste or an increase in the metal content of the water. This condition is avoidable by installing the cooler using the proper materials as shown.

NOTICE

This water cooler must be connected to the water supply using a dielectric coupling. The cooler is furnished with a non-metallic strainer which meets this requirement. The drain trap which is provided by the installer should also be plastic to completely isolate the cooler from the building plumbing system.

Model shown with Flexi-Guard StreamSaver Bubbler.

Bottle Filler unit will mount on bracket attached to wall by 6 holes (as shown). Water and electrical will connect through pre-punched hole in basin.

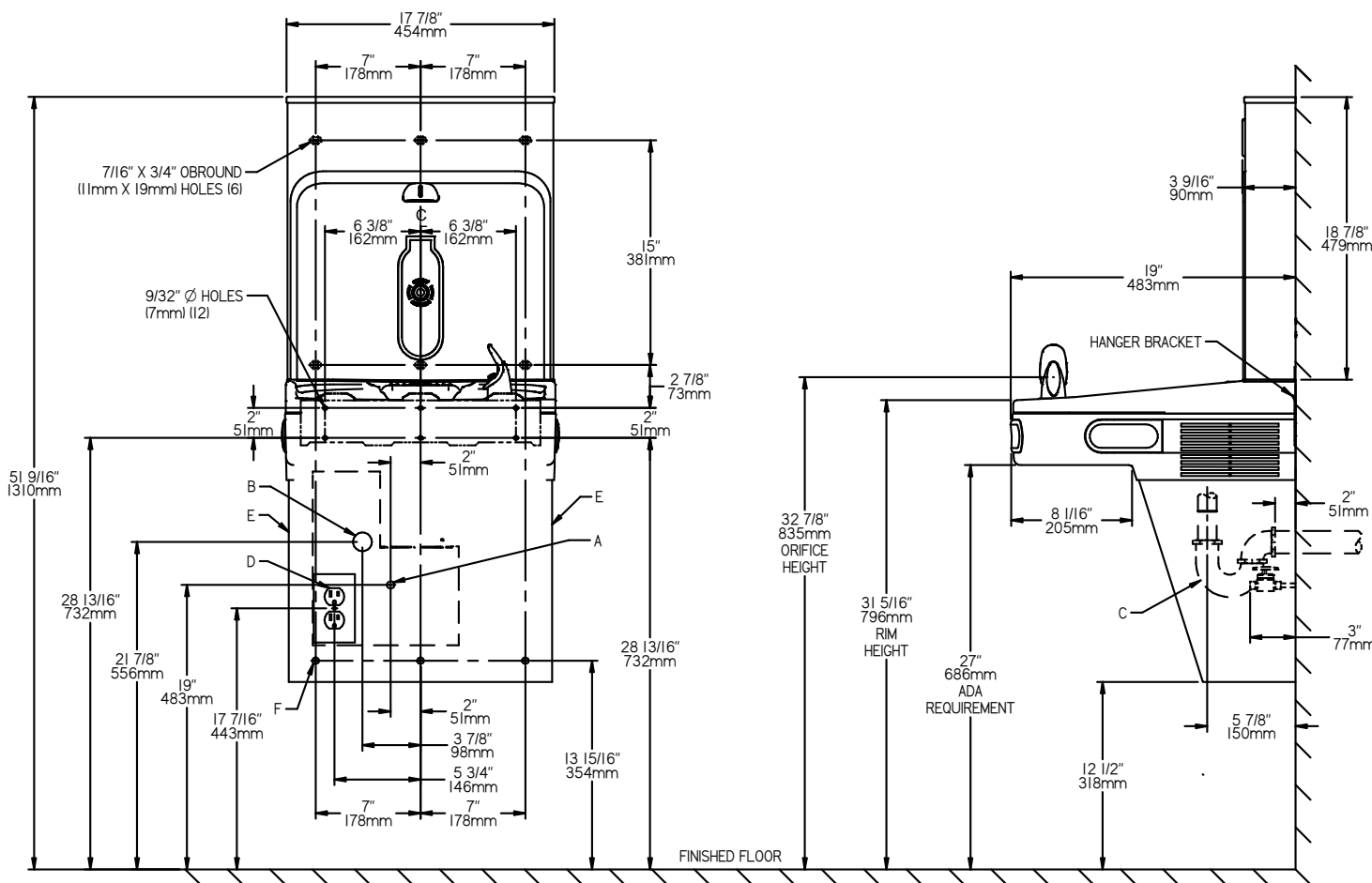

REDUCE HEIGHT BY 3 INCHES FOR INSTALLATION OF CHILDRENS ADA COOLER

LEGEND:

- A = Recommended Water Supply location. Shut-off Valve (not furnished) to accept 3/8" O.D. unplated copper tube. Up to 3" (76mm) maximum out from wall.
- B = Recommended Waste Outlet location. To accommodate 1-1/4" nominal drain. Drain stub 2" (51mm) out from wall.
- C = 1-1/4" Trap (not furnished).
- D = Electrical Supply (3) Wire Recessed Box Duplex Outlet.
- E = Insure proper ventilation by maintaining 6" (152mm) minimum clearance from cabinet louvers to wall.
- F = 7/16" (11mm) Bolt Holes for fastening to wall.

**New Installations Must Use Ground Fault Circuit Interrupter (GFCI).

Job Name: _____
 Model: _____ Qty. _____
 Contact: _____
 Approval Signature: _____
 Notes: _____



B-0831

Slow Self-Closing Metering Faucet

Architect/Engineering Specifications:

4" centerset deck mount mixing faucet with polished chrome plated brass body and integral spout, 2.2 GPM aerator, metering cartridges, push button caps and 1/2" NPSM male inlets. Certified to ASME A112.18.1/CSA B125.1, NSF 61-Section 9 and NSF 372. Meets ADA ANSI/ICC A117.1 requirements.

Job Name _____
 Model Specified _____ Quantity _____
 Variations Specified _____
 Date _____

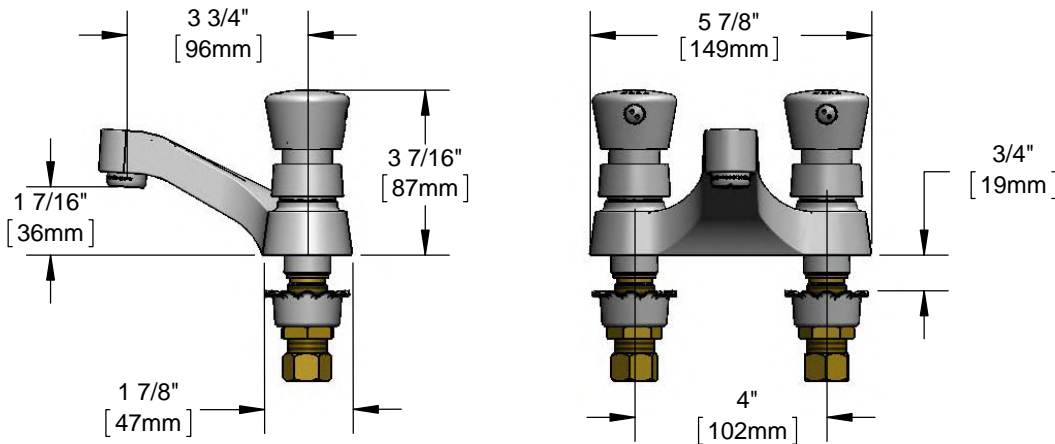

Features & Benefits:

- 4" centerset deck mount mixing faucet w/ polished chrome plated brass body and integral spout
- 2.2 GPM aerator, Series 3 (B-0199-03)
- Metering cartridges
- Adjustable metering cycle, 10 to 30 seconds
- Push button (hot & cold) caps w/ vandal resistant screws
- 1/2" NPSM male inlets
- Material: Polished chrome plated brass body & spout and chrome plated metal caps

Product Compliance:

- ASME A112.18.1 / CSA B125.1
- NSF 61 - Section 9
- NSF 372 (Low Lead Content)
- ANSI A117.1 (ADA)



Warranty: One Year (Limited)

Performance Data:

- Pressure: 20 - 125 psi
- Temperature: 40 °F - 140 °F
- Flow Rate: 2.2 GPM @ 60 psi
- Water Consumption: @ 10 sec = .37 gal
@ 15 sec = .55 gal



Optional Outlets (Series 3 / VR Series 8)

GPM	Aerated	Non-Aerated (Laminar)	VR Aerated	VR Non-Aerated (VR Laminar)	Optional Cartridges
0.35	N/A	<input type="checkbox"/> B-0199-03-N035	N/A	<input type="checkbox"/> B-0199-08-N035	<input type="checkbox"/> Push Button Metering (Standard)
0.5	N/A	<input type="checkbox"/> B-0199-03-N05	N/A	<input type="checkbox"/> B-0199-08-N05	<input type="checkbox"/> Pivot Action Metering
1.0	N/A	N/A	N/A	<input type="checkbox"/> B-0199-08-LF-10	<input type="checkbox"/> Wrist Action Metering
1.5	<input type="checkbox"/> B-0199-03-WS	N/A	<input type="checkbox"/> B-0199-08-WS	N/A	
2.2	Standard	<input type="checkbox"/> B-0199-26	<input type="checkbox"/> B-0199-08	<input type="checkbox"/> B-0199-28	



Cover Sheet

Vote to Approve Maintenance Overhaul

Section: VII. Facilities Update
Item: B. Vote to Approve Maintenance Overhaul
Purpose: Vote
Submitted by:
Related Material: Facilities Support Associate.pdf
Maintenance Overhaul.pdf



Facilities Associate

Job Summary

Ivy Hill Preparatory Charter School is one that ensures that all children are held to the same bar of excellence. Join Ivy Hill as part of the facilities support team! This position is designed to assist the Director of Operations at Ivy Hill Prep. Responsibilities include: maintaining the school campus, light repairs and performing other daily operational tasks.

Key Responsibilities

- General maintenance of all IHP property including parking lot areas; General building upkeep.
- Receiving of all deliveries and ensuring that they are securely packed and covered in storage room.
- Ability to perform various clean-up and maintenance tasks as needed;
- Perform minor repairs such as ceiling, tile changing, stopping of leaks wherever required, etc.
- Clean and maintain in front of building by keeping area free of garbage and clean at all times.
- Ability to update inventories and other supplies as needed as per approved by the corps officer.
- Ability to inspect, operate and maintain the heating, cooling and ventilation system and the boiler system.
- Does general repairs such as painting, patching walls, security hardware, hanging shelves and landscaping.
- Coordinates renovations of existing facilities and the construction of new facilities.
- Cafeteria: Empty, wash, and disinfect garbage bins, sweep & mop floor; wipe down and sanitize tables and chairs
- Outside of Building – Sweep, and keep clear of litter and trash, glass, etc.; Remove snow and ice, when necessary. Hose down front entrances when weather permits
- Wash/Wipe light domes or bulbs, as needed

- Wash and disinfect mop heads (hang to dry spreading strand); Change water frequently
- Clean up utility rooms and closets; sweep and hose down boiler room; Wash windows and blinds as needed (inside & outside); Wash baseboards periodically
- Strip floors and wax, as needed; Buff floors on a quarterly basis
- Be willing to assist with outside agencies use of facilities
- Perform other tasks as per DOO specific instructions, to maintain a healthy, sanitary, hazard free environment.
- Set up and break down rooms for special events

Salary & Benefits

Ivy Hill Prep offers a competitive salary, comprehensive health benefits, and retirement benefits. Aside from extensive professional development, all of our staff members are equipped with all necessary tools to complete their jobs effectively.

Commitment to Diversity

Ivy Hill Prep is an equal opportunity employer and does not discriminate on the basis of race, color, religion, gender, sexual orientation, national or ethnic origin, age, disability, pregnancy or veteran status.

Apply Now!

Please send a resume and cover letter to ajohnson@ivyhillprep.org.

Ivy Hill Prep

IHP Maintenance Overhaul

4th December 2019

OVERVIEW

Management has noticed deficiencies with the current cleaning company *Reliable Office Cleaning Services LLC*. In regards to this matter, Management has decided to explore bringing our Janitorial and Maintenance services in-house by hiring two custodial staff members to be a part of the Operations Team. This will not only ensure complete oversight of our school but reduce the overall cost not only in Year one but further years as we expand towards full enrollment and occupancy. This will require us to end our agreement with *Reliable Office Cleaning Services LLC*.

GOALS

1. To reduce deficiencies in regards to our janitorial and maintenance services.
2. To effectively reduce cost.
3. To maximize the school quality and continue on the path of operational excellence.

SPECIFICATIONS

Reliable Cleaning Services	IHP In House Services	Notes:
Cost: \$86,400yr / \$7200 a month	Salaries: Eduardo: \$36,000 Henry: \$30,000	Total Salaries including insurance: \$67,340 Total Savings \$12,400
Reliable does not include snow removal. Additional cost to IHP \$150/hr	IHP In House, would not require additional charges for services through the year.	Bearing in mind the upcoming renovations, our in-house team would be able to provide additional services to ensure we meet our current deadline and remain within budget.
Does not include electric services. I.e changing bulbs	Eduardo and Henry both are able to provide that service for	We currently outsource that with Small Island Maintenance.

	us.	Average cost \$500
Includes supplies procured through Nazareth HS.	Will replace all dispensers acquired by IHP from WB Mason for free.	IHP will procure products through WB Mason
	Job description: HERE	Materials list: HERE

MILESTONES

Management has conducted interviews on December 2nd. The two candidates for the roles of Facilities Associate and Custodian/ Maintenance Associate are Eduardo Mardones and Henry Washington respectively. Both gentlemen have over two decades of experience in janitorial, handyman and maintenance services. Both are familiar with the space and the custodial manager for IHP’s landlord *Nazareth HighSchool*.

We will be moving forward with both candidates with the expected start date of *insert start date here*

Management will be concluding the contract with *Reliable Office Cleaning Services LLC* on *insert date here*

Cover Sheet

HOS Report

Section: VIII. Head of School Update
Item: A. HOS Report
Purpose: Discuss
Submitted by:
Related Material: Head of School Report_December.docx
Head of School Report_January.pdf



Ivy Hill Prep Board of Trustees

Head of School REPORT

IVY HILL PREPARATORY CHARTER SCHOOL

Head of School REPORT

12-19-19

Submitted by: Ambrosia Johnson

I. Facility Update

- All proposals for 2nd floor construction have been received.
- Next steps: Fine tweaking proposals to finalize.
- Dec Meeting: Goal for proposals to be presented to the full Board.

II. Enrollment Report

Accepted Offers / Seats Available

	Kindergarten	1 st Grade
Target	88	32
Current Accepted Offers	83 / 88	31 / 32
Gap	5	1
Waitlist	0	0

III. Hiring Report

Position	Total Needed	Total Hired	Goal of Hire	Current Status
Head of School	1	1	N/A	Completed.
Office Coordinator	1	1	N/A	Completed.
Director of Operations	1	1	N/A	Completed.
Teacher	8	8	N/A	Completed.
Dean of Special Supports	1	1	N/A	Completed.
Martial Arts Instructor	1	1	N/A	Completed.

Dance Instructor	1	1	N/A	Completed.
School Social Worker	1	1	N/A	Completed.
DOE Counselor				
Nurse	-	-	N/A	Completed.
Teaching Fellow	1	0	ASAP	Completed.
Total Hires Needed:		16		
Total Hired:		15		

Updates:

1. Switch in Martial Arts Instructor
 - Already began.
2. Switch in School Social Worker
 - Begins at the start of the new year

IV. School Updates

1. Application for SY 2020-2021

- Application updates can be found in the Academic Dashboard.
- Application Count: 126 applications for 70 seats.

2. School Academics

- STEP Round 2 completed on December 13th.
- STEP Analysis meeting on January 3rd.
- STEP results will be available at January Board Meeting.
- Math IA #2 on Jan 28 & Jan 29
- MATH IA results will be available at February Board Meeting

3. School Culture and Events

- Winter Holiday Show: Dec 18
- Winter Wonderland: Dec 19
- *A Mother’s Dream Toy Drive*: Dec 20

December Events

- December Open House: Dec 12
 - i. 35 participants

- Winter Holiday Show: Dec 18
- Winter Wonderland: Dec 19
- *A Mother's Dream Toy Drive*: Dec 20
- Dec 23 – Jan 2: Holiday Break
- Jan 3: Staff Data Day

January Events

- School Closed for MLK Day: Jan 20

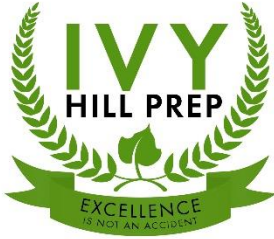

Ivy Hill Prep Board of Trustees

Head of School REPORT

IVY HILL PREPARATORY CHARTER SCHOOL

Head of School REPORT

1-28-20

Submitted by: Ambrosia Johnson

I. Facility Update

- All proposals for 2nd floor construction have been received.
- Next steps: Vote to approve contractor.

II. Enrollment Report

Accepted Offers / Seats Available

	Kindergarten	1 st Grade
Target	88	32
Current Accepted Offers	83 / 88	31 / 32
Gap	5	1
Waitlist	0	0

III. Hiring Report

Position	Total Needed	Total Hired	Goal of Hire	Current Status
Head of School	1	1	N/A	Completed.
Office Coordinator	1	1	N/A	Completed.
Director of Operations	1	1	N/A	Completed.
Teacher	8	8	N/A	Completed.
Dean of Special Supports	1	1	N/A	Completed.
Martial Arts Instructor	1	1	N/A	Completed.
Dance Instructor	1	1	N/A	Completed.

School Social Worker	1	1	N/A	Completed.
DOE Counselor				
Nurse	-	-	N/A	Completed.
Teaching Fellow	1	0	ASAP	Completed.
		Total Hires Needed:	16	
		Total Hired:	15	

IV. School Updates

1. Application for SY 2020-2021

- Application updates can be found in the Academic Dashboard.
- Application Count: 213 applications for 70 seats.

2. School Academics

- STEP Round 2 completed on December 13th.
- STEP Analysis meeting on January 3rd.
- STEP results are now available: January Board Meeting.
- Math IA #2 on Jan 28 & Jan 29
- MATH IA results will be available at February Board Meeting

January Events

- **Jan 14:** Open House #1 for the month
 - i. 55 participants
- **Jan 15:** My Face Presentation
- **Jan 20:** School Closed for MLK Day:
- **Jan 20:** Ivy Hill Prep partnering with Ameri Corps and Public Allies NY for MLK Day of Service
- **Jan 30:** Family Chat

Cover Sheet

Meeting Evaluation

Section: IX. Closing Items
Item: A. Meeting Evaluation
Purpose: Discuss
Submitted by:
Related Material: Board Meeting Evaluation.pdf



Board Meeting Evaluation

I invite you to critically review the work we are doing as a board. At the end of each meeting one trustee member will volunteer to provide feedback below.

1. What did we do tonight to further our mission?

2. How much time was spent reporting on the past vs planning for the future

3. Did we stick to the agenda?

Through high-quality curriculum and instruction, intentional leadership development, and a commitment to excellence in all that we do, Ivy Hill Preparatory Charter School educates kindergarten through fifth grade scholars to thrive in middle and high school, graduate from the college of their choice, and access lives of purpose and opportunity.



Board Meeting Evaluation

4. Was there equal participation by board members?

5. Was the meeting effective? Why or why not?

6. What could have been done to improve the board meeting?

Name: _____ **Position:** _____

Through high-quality curriculum and instruction, intentional leadership development, and a commitment to excellence in all that we do, Ivy Hill Preparatory Charter School educates kindergarten through fifth grade scholars to thrive in middle and high school, graduate from the college of their choice, and access lives of purpose and opportunity.

Attachments

The following files are attached to this PDF: You will need to open this document in an application that supports attachments (i.e. [Adobe Reader](#)) in order to access these files.

Ivy Hill Monthly Financials - December 2019 (1).xlsx

Ivy Hill Monthly Financials - November 2019 (12.16.19).xlsx

Final Budget Approved on 11-25-19.xlsx

Academic Dashboard October 2019 - Jan 2020.xlsx